

SOUNDPROOF CABINET – SC6M - SC8M

CHARACTERISTICS:

- Suitable for MOR blowers only.
- Suitable for outdoor installations.
- Noise reduction **10 dB(A)** max.
- With electric axial fan (1) removing heat, generated by the motor and blower (2).
- With air inlet grille for ventilation.(3).
- Steel sheet structure (4).
- Folding roof opening (90°), for blower installation/inspection (5).
- Internal coated with polyurethane foam (sound-absorbing material) (6).
- Complete with accessories for blower connection (7), assembly with 4 shock mounts washer
- Cabinet with feet.
- Palletizable.
- Stackable cabinet (max 2 pieces) (8).
- Paint RAL 9001.
- On request, available in assembly kit.

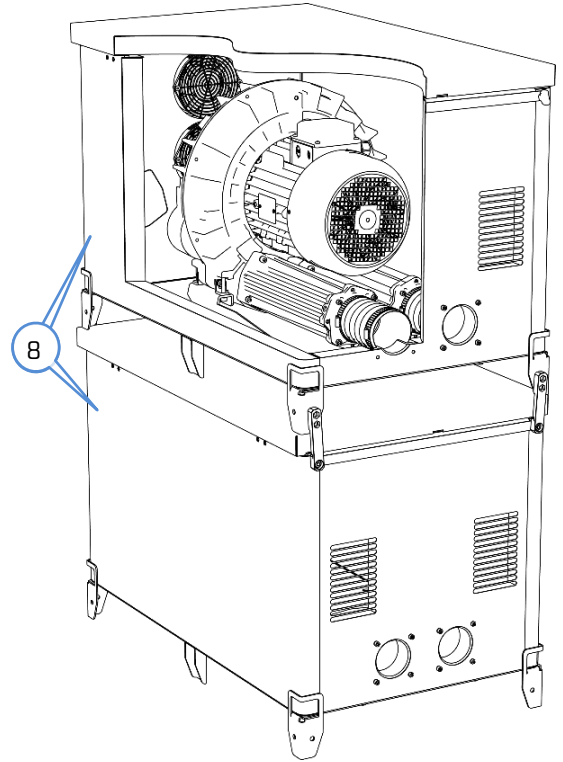
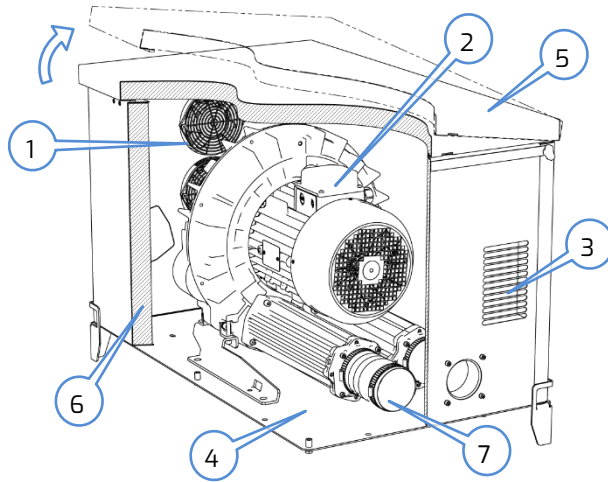

CODE	WEIGHT*	MOR BLOWER COMPATIBLE				AXIAL ELECTRIC FAN (1)							
	kg	MS	MD	TS	TD	q.tà	Hz	V	W	mA	Phase	Pole	IP
255C 6 M - 2	40		K/e07 K/e08			2	50	230	46	300	1	2	54
255C 6 M - 3	40				K05 K06		60		44	280			
255C 8 M - 1	51	K/e07 K/e08	K75		K05 K06								
255C 8 M - 2	52				K/e07 K/e08								

*- Weight cabinet only

DIMENSION (SC6M-1)

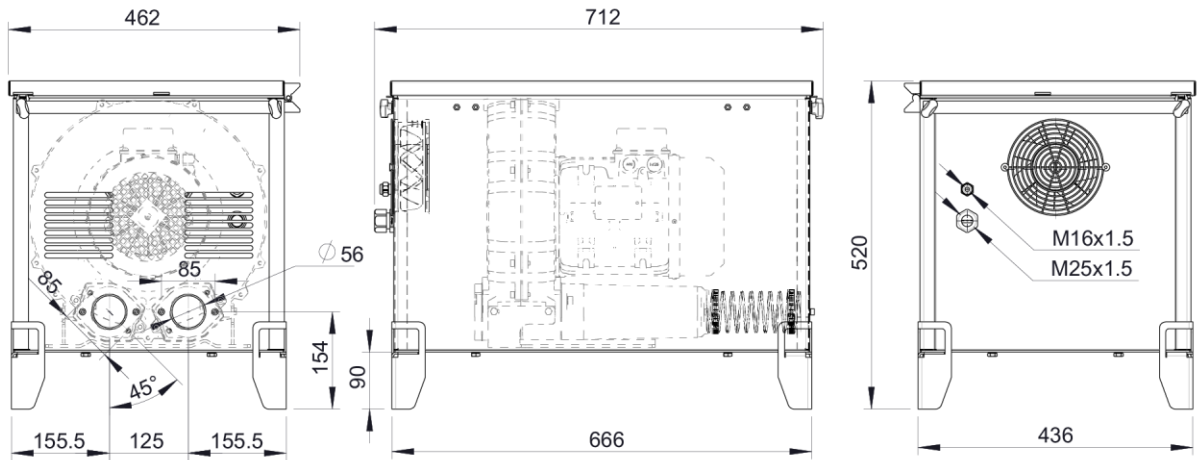

DIMENSION (SC6M-2)

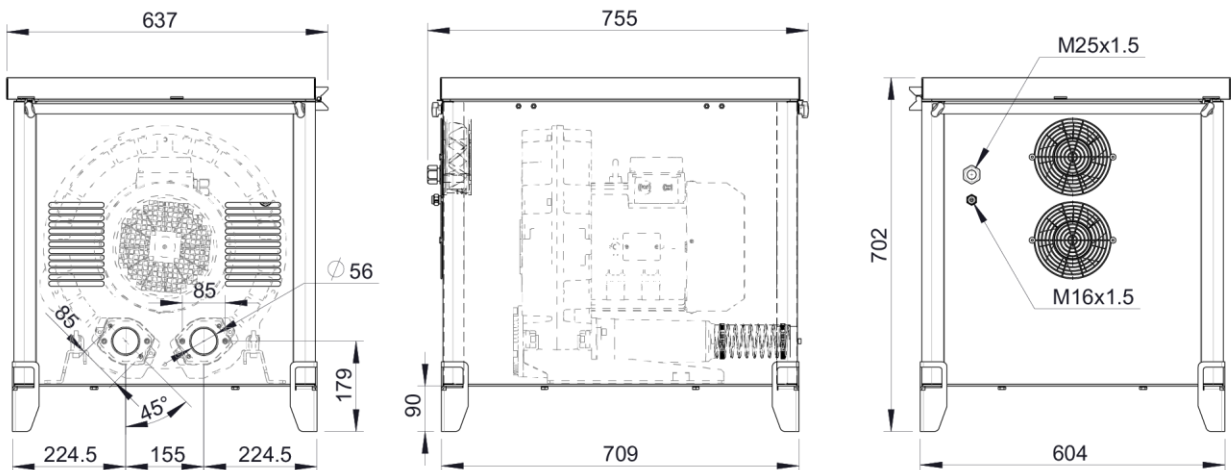

DIMENSION (SC6M-3)

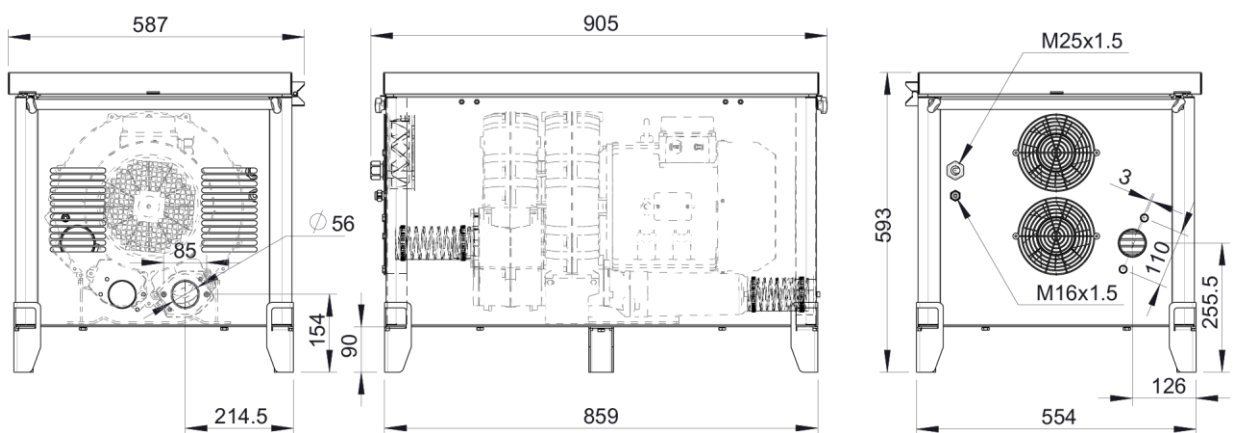

DIMENSION (SC8M-1)

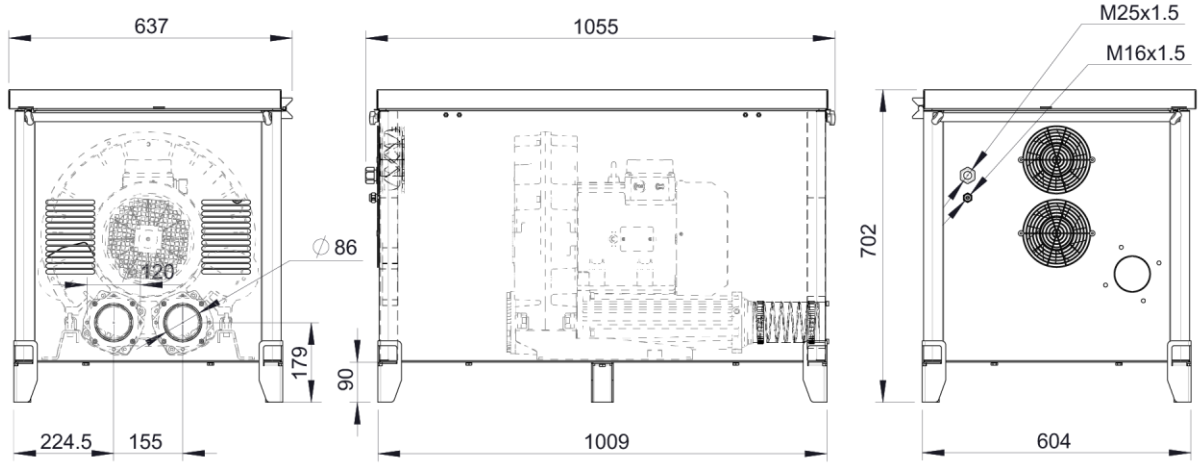

DIMENSION (SC8M-2)

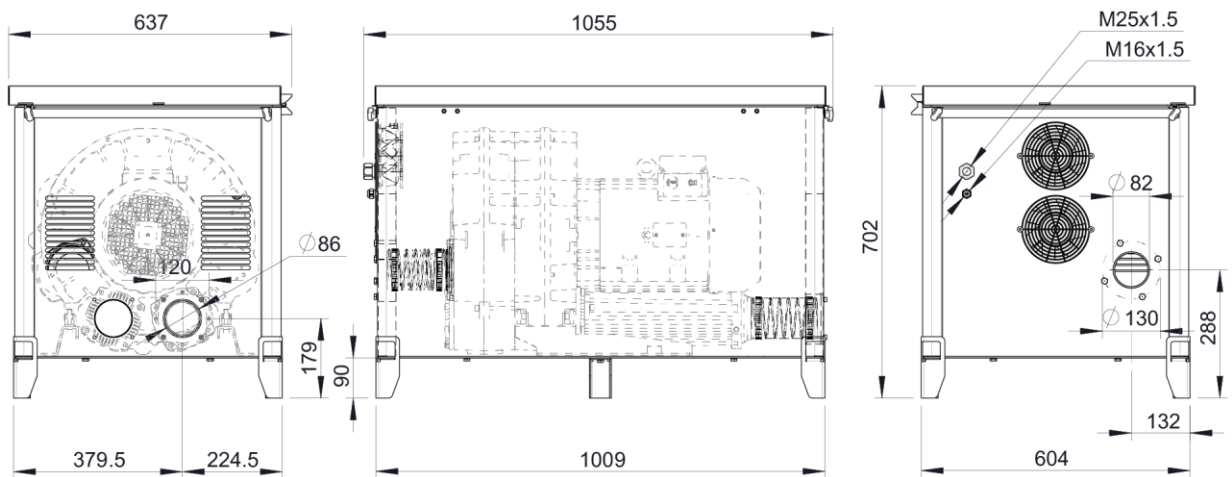

SOUNDPROOF CABINET – SC9M – SC10M

CHARACTERISTICS:

- Suitable for MOR blowers only.
- Suitable for outdoor installations.
- Noise reduction **10 dB(A)** max.
- With electric axial fan (1) removing heat, generated by the motor and blower(2).
- With air inlet grille for ventilation.(3).
- Aluminium profile frame (4).
- Sandwich panels insulated with mineral wool (sound absorbing / sound insulation) (5).
- Demountable panels with block-panel (6).
- Assembly from top (drop on the blower).
- Floor fixing points available (x2) (7).
- Polyester painted panels RAL 7035.

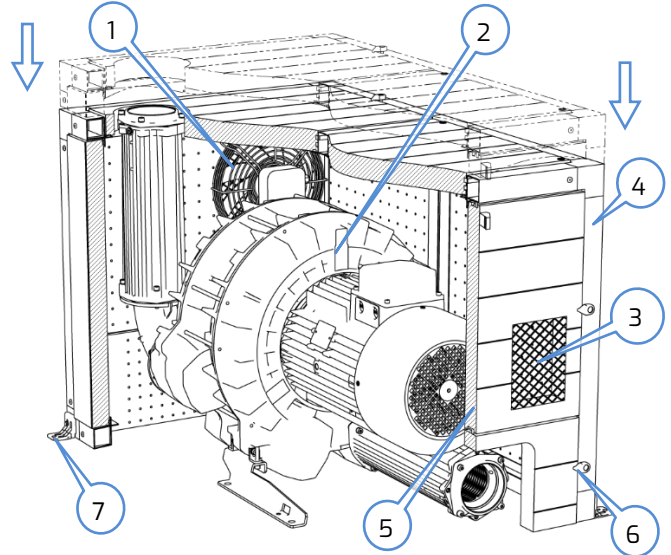

CODE	WEIGHT*	MOR BLOWER COMPATIBLE				AXIAL ELECTRIC FAN**[1]							
	kg	MS	MD	TS	TD	q.tà	Hz	V	W	A	Phase	Pole	IP
255C 9 M - 1	81	K09 K10	K09 K10	K/e07 K/e08		1	50 60	230	90 110	0.42 0.52	1	2	54
		K/e11 K/e12	K/e11 K/e12										
255C 9 M - 2	81				K09 K10								
					K/e11 K/e12								
255C 10 M	81			K09 K10									
				K/e11 K/e12									

* - Cabinet weight only
 ** - Capacitor 3µF 450V

NOTE

- Stackable cabinets (255B accessory required) for max 2 units. Not applicable to cabinet code 255C9-2, only if used as a base (TD blower)

DIMENSION (SC9M-1)

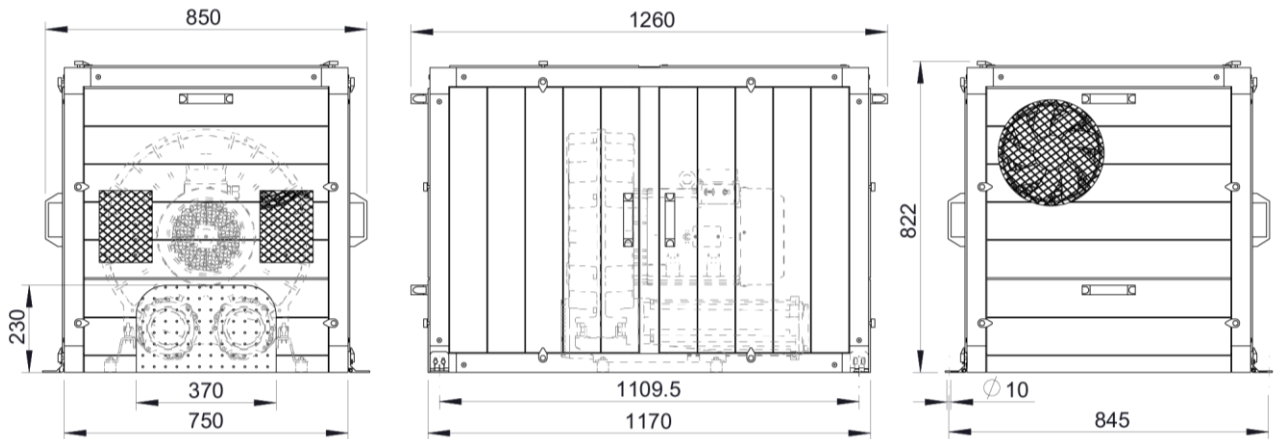

DIMENSION (SC9M-2)

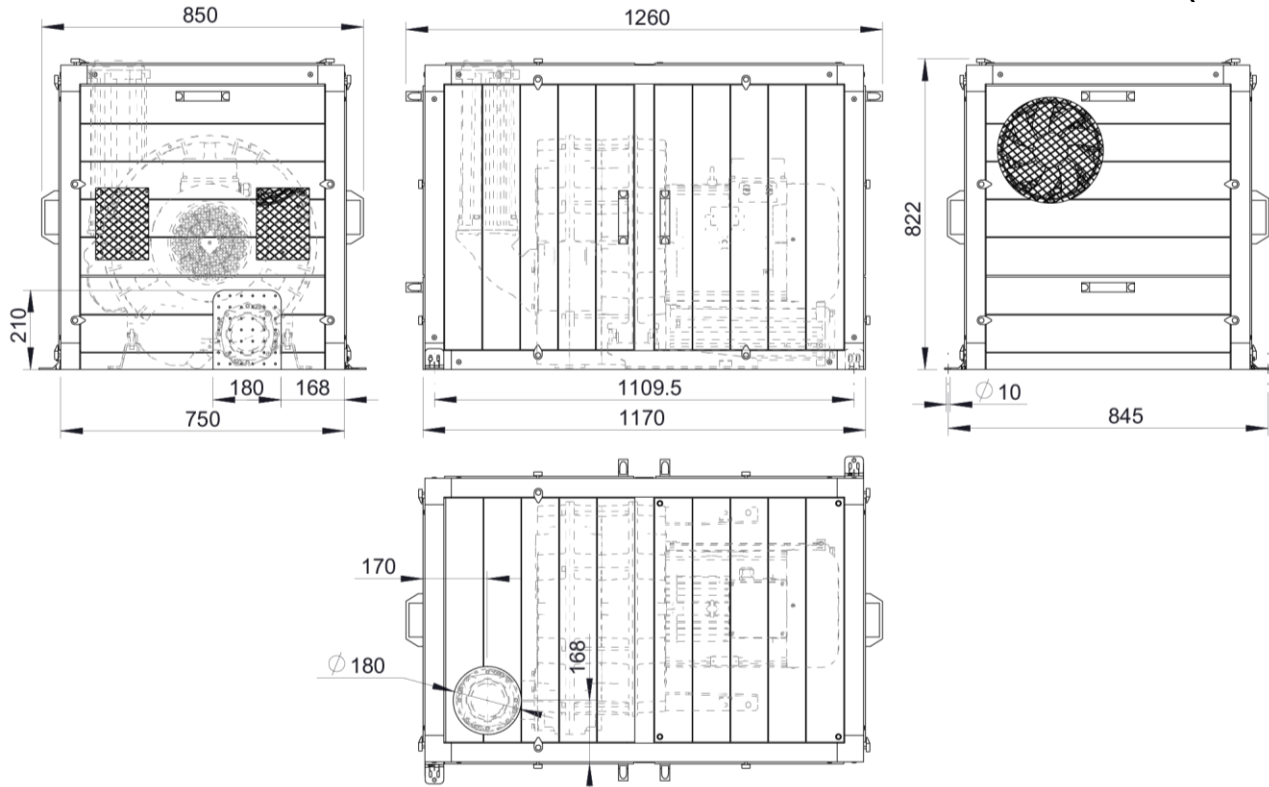

DIMENSION (SC10M)

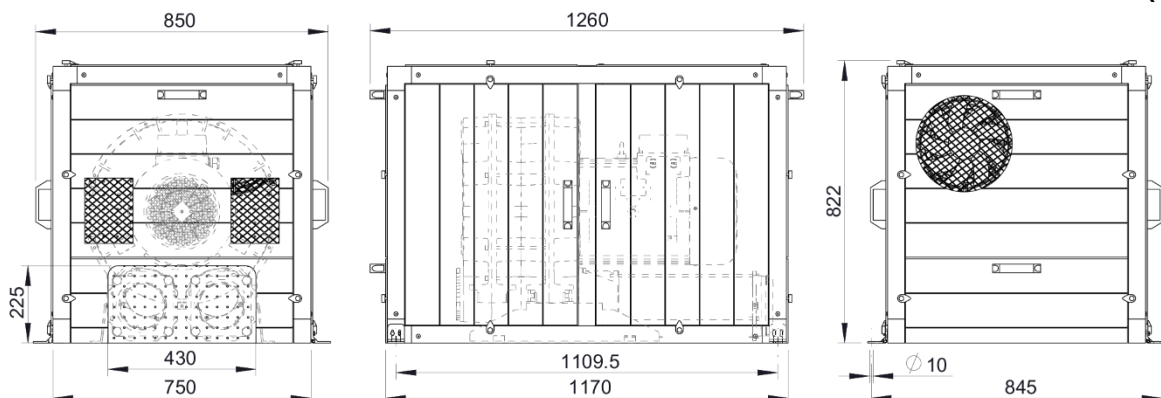

SOUNDPROOF CABINET BASE - 25SB-1 (SUITABLE FOR SC9M-1 / SC9M-2 / SC10M)

CHARACTERISTICS:

- Suitable for outdoor installations.
- Aluminium profile frame (1).
- Sandwich panels insulated with mineral wool (sound absorbing / sound insulation) (2).
- Omega for blower fixing (3) assembly with 4 shock mounts washer
- Fixing with blower by hinge (4)
- Makes the cabinet Palletizable
- Makes the cabinet stackable (max 2 pieces) (5)
- Polyester painted panels RAL 7035.

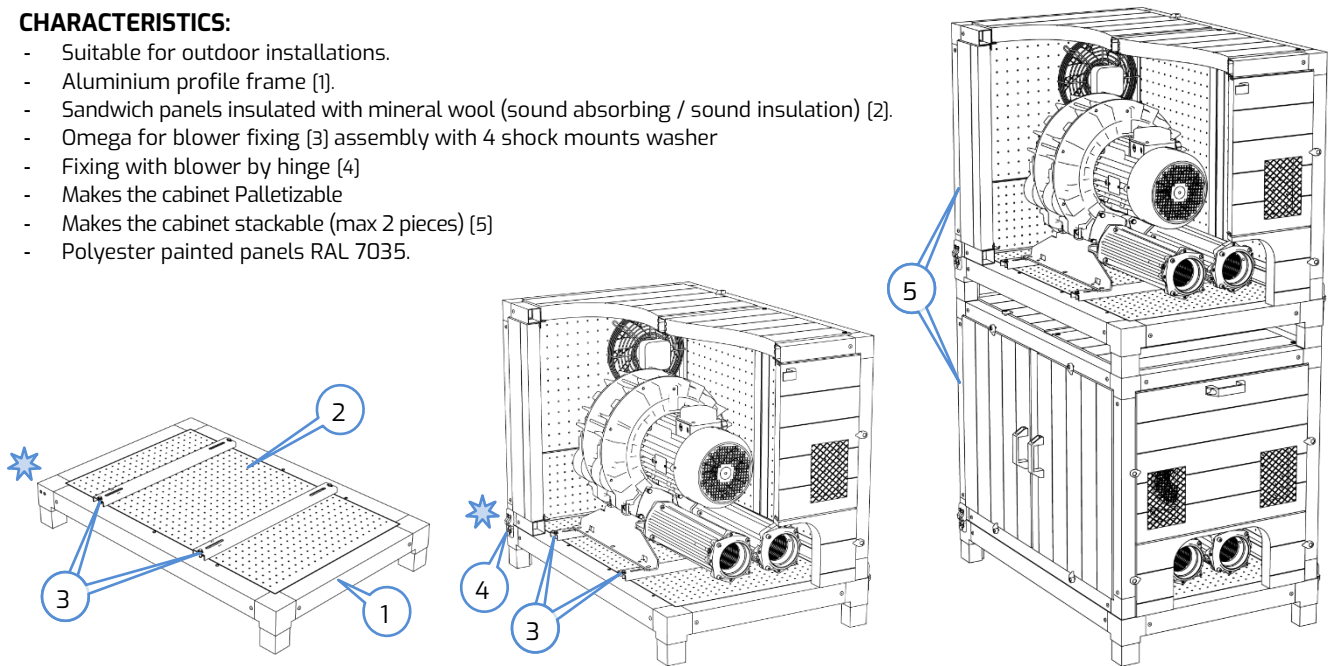

DIMENSION (SB-1)



OMEGA POSITION FOR BLOWER INSTALLATION (4)

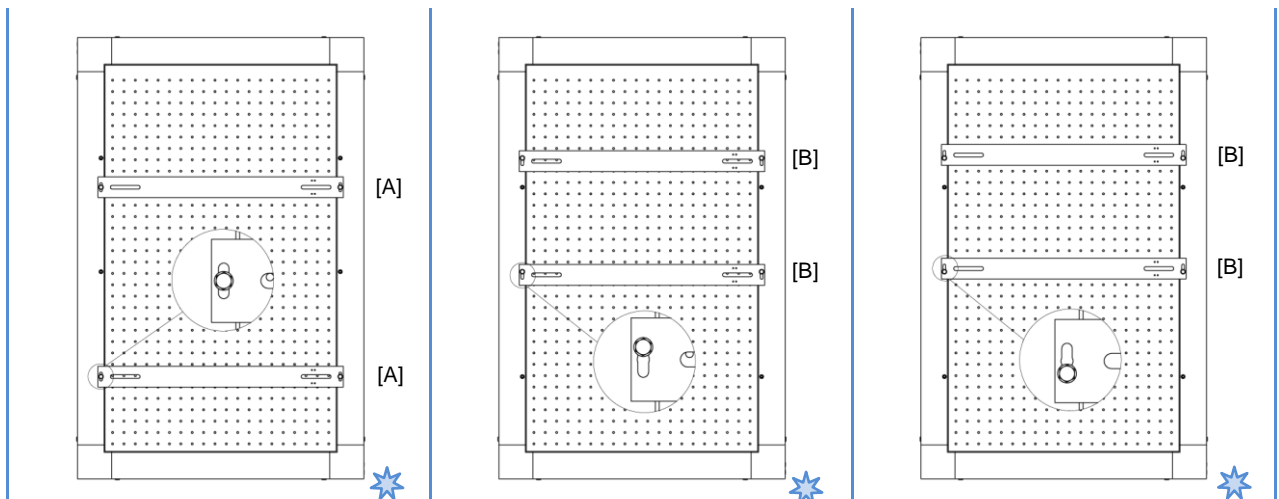

MS						K09	K10	K/e11	K/e12
MD						K09	K10	K/e11	K/e12
TS	K/e07	K/e08	K09	K10	K/e11	K/e12			
TD						K09	K10	K/e11	K/e12