

volution

A NEW GENERATION
OF BLOWERS



PRODUCED BY





FPZ's evolution series is the next generation of blowers. e Series blowers are drop in replacements for their K series equivalent and feature increased efficiency, lower discharge temperatures and a significant reduction in perceived noise.

FPZ's new impeller design reduces the tonal peaks resulting in both measurable and perceived noise. FPZ's 3D printing and rapid prototyping allowed us to optimize the design resulting in the uniquely spaced impeller blades found in the e Series – a new generation of blowers.



HIGH EFFICIENCY



LOWER OUTLET TEMPERATURE

THE TEMPERATURE RISE IS REDUCED UP TO 15%



IMPROVED SOUND QUALITY

LOWER PERCEIVED NOISE:
THE PROMINENCE OF TONAL
NOISE PEAKS IS
REDUCED UP TO 6dB



INDUSTRIAL PATENT

THE OPTIMIZED IMPELLER DESIGN IS PATENTED



3 YEAR WARRANTY

ALL OF OUR BLOWERS ARE BACKED BY OUR INDUSTRY LEADING 3 YEAR WARRANTY.



STANDARD IE3 MOTOR

STANDARD BLOWERS ARE EQUIPPED WITH IE3 PREMIUM EFFICIENT MOTORS





SS2007

Table of Contents

<i>evolution - Single Stage</i>	Type	Max CFM	Max Pressure (In H ₂ O)	Max Vacuum (In H ₂ O)	Page #
SCL e07-MS	Single Stage Blowers	307	160	140	4-5
SCL 08-MS	Single Stage Blowers	394	170	130	6-7
SCL e07-TS	Single Stage Blowers	582	100	110	8-9
SCL e08-TS	Single Stage Blowers	712	60	60	10-11

evolution - Two Stage

SCL e08-MD	Two Stage Blowers	177	260	180	12-13
SCL e07-TD	Two Stage Blowers	304	220	170	14-15
SCL e08-TD	Two Stage Blowers	406	160	170	16-17

Values in above table based on 60 hz performance

Accessories

Installation Guide	General guide on how to install accessories.	18
VRL6-9	Safety Valves	19
FS	Filters & dirty filter indicator for pressure applications	20
CSL / CT	Filters for vacuum applications.	21
VG / PG / CV / SS / IH	Gauges, Check Valves, Silencers, and Sound Enclosures	22

MORE MODELS COMING SOON!

The patented impeller design was developed through sound quality studies and rapid prototyping. The resulting design has a targeted reduction of the most displeasing frequencies.

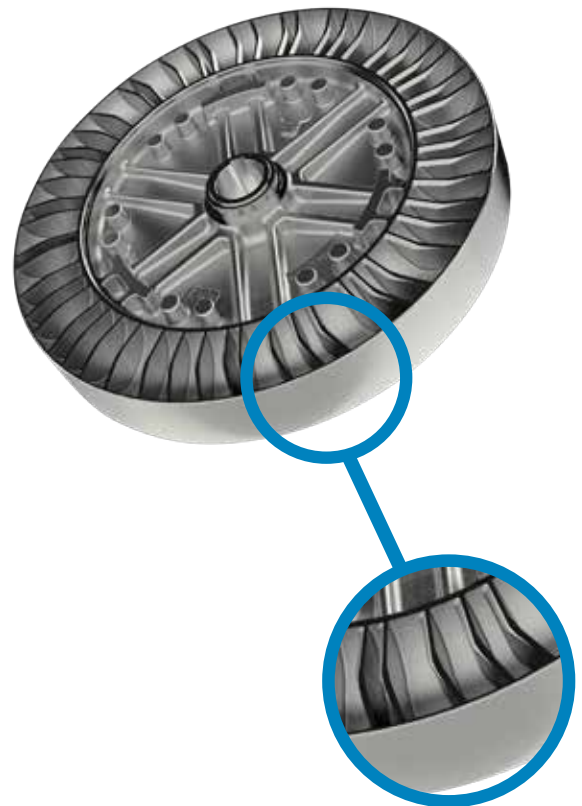
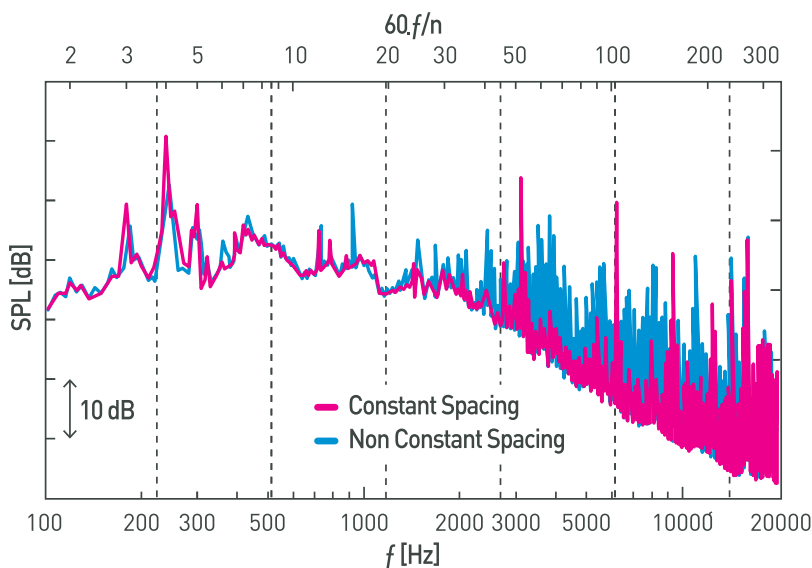



**Evolution Series
Technical Characteristics**

- Premium efficient motor
- High efficiency impeller
- Mountable in any position
- Maintenance free operation
- TEFC (IP55)

Optional Features

- Anodized aluminum components for corrosion resistance
- Increased sealing

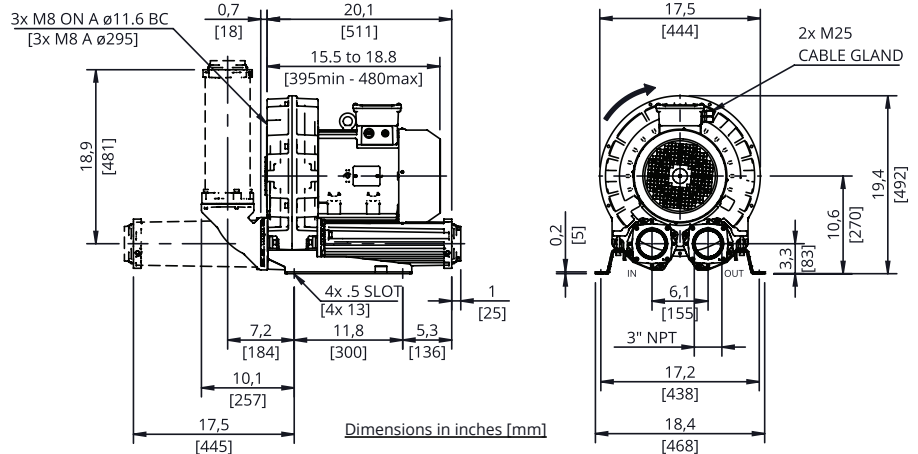

Technical Specifications

Model No.	HP	Hz	Open Flow (cfm)	Max Pressure in. H ₂ O	Max Vacuum in. H ₂ O	Efficiency	Voltage	FLA	Starting Current Ratio ¹	dB(A) ²	Weight (lb)
SCL e07-MS-4-3	4	60	307	40	40	88.5%	208-230/460	10.9-11.1/5.53	11	75	130.1
		50	254	60	60	87.1%	200/400	12.86/6.38		71	
SCL e07-MS-4-3-575	4	60	307	40	40	88.5%	575	3.94	10.1	75	130.1
SCL e07-MS-5.5-3	5.5	60	307	70	70	88.5%	208-230/460	14.6-15.1/7.55	11.1	75	132.3
		50	254	100	100	88.1%	200/400	17.7/8.86		71	
SCL e07-MS-5.5-3-575	5.5	60	307	70	70	88.5%	575	5.31	10.9	75	132.3
SCL e07-MS-7.5-3	7.5	60	307	110	110	89.5%	208-230/460	19.8-19.5/9.75	13.7	75	174.2
		50	254	140	110	89.2%	200/400	22.2/11.1		71	
SCL e07-MS-7.5-3-575	7.5	60	307	110	110	89.5%	575	7.21	13.5	75	174.2
SCL e07-MS-10-3	10	60	307	160	140	90.2%	208-230/460	26.1-25/12.5	13	75	185.2
		50	254	-	-	90.1%	200/400	28.6/14.3		71	
SCL e07-MS-10-3-575	10	60	307	160	140	90.2%	575	10	12.9	75	185.2

Motors include normally closed thermal protector, 1.15 S.F. (60 Hz), tropicalized windings, Class F (B) insulation, and are suitable for use with a VFD (Contact FPZ for pneumatic and speed limits when used with a VFD).

¹Starting current ratio x fla = starting current

²Noise level measured at a distance of 1 m with inlet and outlet ports piped in accordance to ISO 3744

Data is subject to change without notice.

Recommended Accessories

Description	Pressure Safety Valve	Vacuum Safety Valve	Pressure Filter	Vacuum Filter	Check Valve
Part Number	VRL6 (7.5 hp & 10 hp) ³	VRL6 (5.5hp - 10 hp)	FS-231P-300	CT-235P-300C	CV30
	VRL8 (4 hp & 5.5 hp) ³	VRL8 (4 hp)			

³Valve selections are based on 60 Hz and standard air. Valves are supplied uncalibrated. Safety valves are easy to calibrate, but can be ordered with factory calibration.



PRESSURE

VACUUM

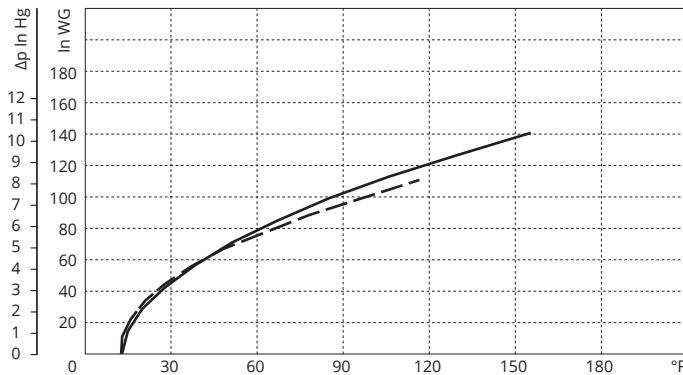
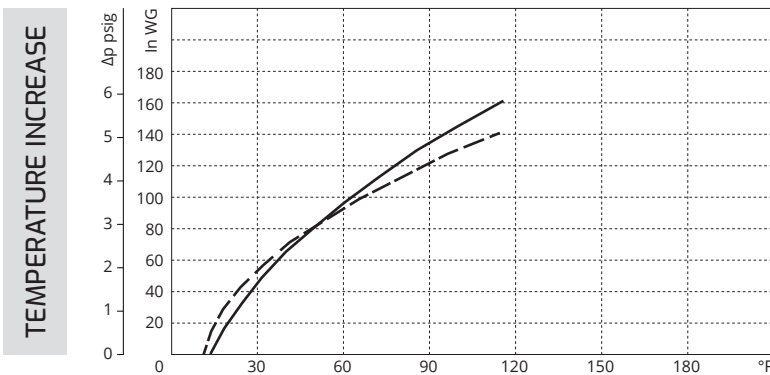
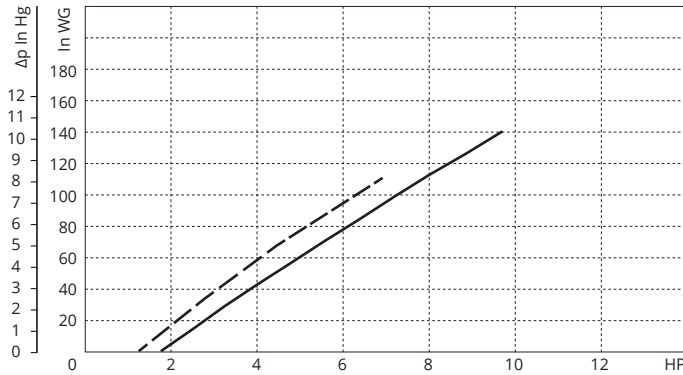
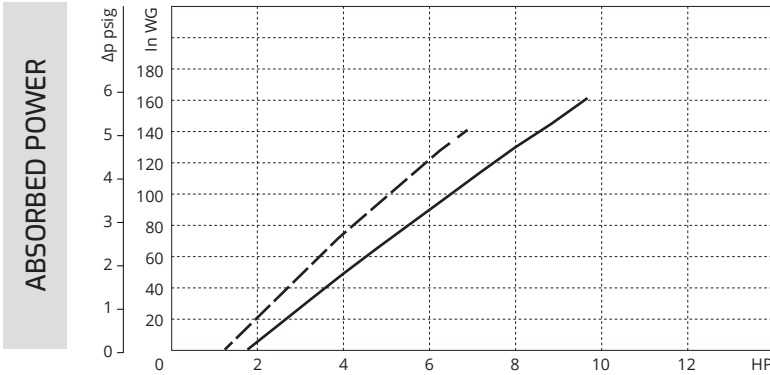
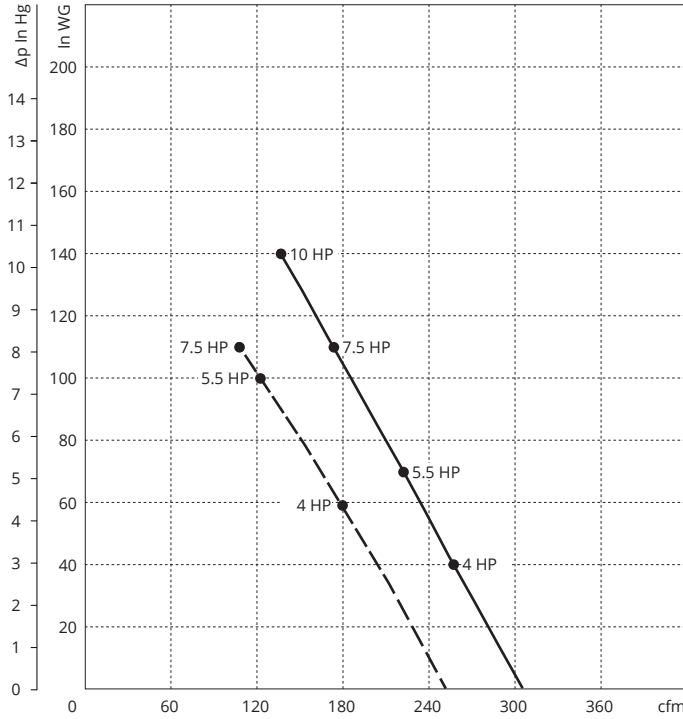
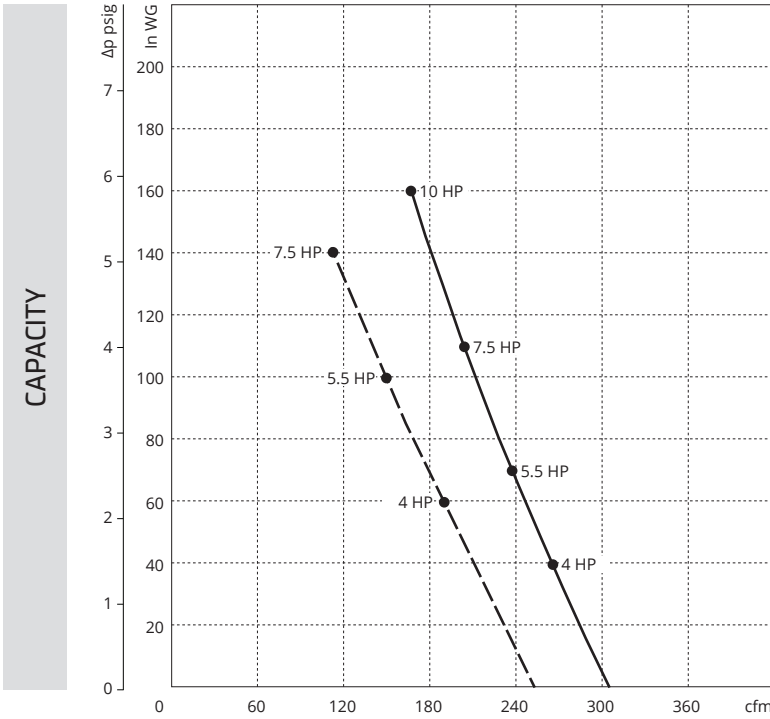

Curves refer to air at 68°F temperature and 29.92 In Hg atmospheric pressure (abs) measured at inlet port.
 Values for flow, power consumption and temperature rise: +/-10% tolerance.
 Data subject to change without notice.

KEY --- 50 Hz
 ——— 60 Hz



**Evolution Series
Technical Characteristics**

- Premium efficient motor
- High efficiency impeller
- Mountable in any position
- Maintenance free operation
- TEFC (IP55)

Optional Features

- Anodized aluminum components for corrosion resistance
- Increased sealing

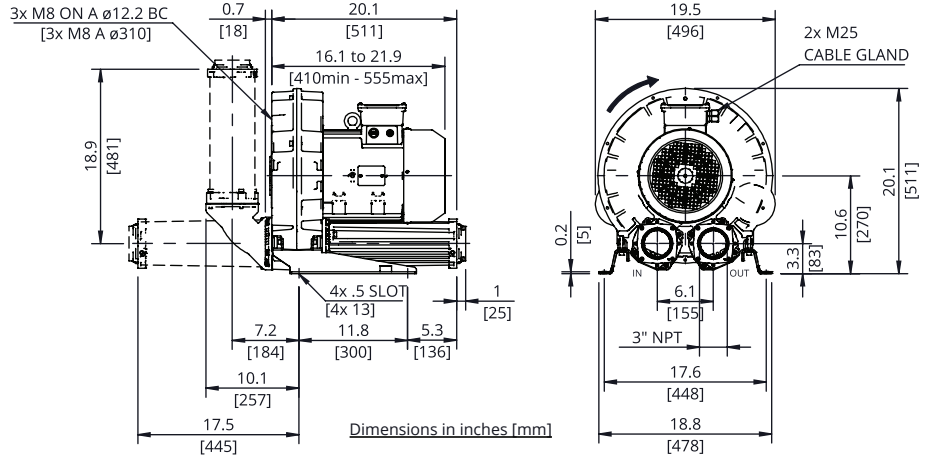

Technical Specifications

Model No.	HP	Hz	Open Flow (cfm)	Max Pressure in. H ₂ O	Max Vacuum in. H ₂ O	Efficiency	Voltage	FLA	Starting Current Ratio ¹	dB(A) ²	Weight (lb)
SCL e08-MS-5.5-3	5.5	60	394	40	40	88.5%	208-230/460	14.6-15.1/7.55	11.1	76.8	138.9
		50	331	70	70	88.1%	200/400	17.7/8.86		72.1	
SCL e08-MS-5.5-3-575	5.5	60	394	40	40	88.5%	575	5.31	10.9	76.8	138.9
SCL e08-MS-7.5-3	7.5	60	394	70	80	89.5%	208-230/460	19.8-19.5/9.75	13.7	76.8	167.6
		50	331	110	110	89.2%	200/400	22.2/11.1		72.1	
SCL e08-MS-7.5-3-575	7.5	60	394	70	80	89.5%	575	7.21	13.5	76.8	167.6
SCL e08-MS-10-3	10	60	394	110	110	90.2%	208-230/460	26.1-25/12.5	13	76.8	180.8
		50	331	150	120	90.1%	200/400	28.6/14.3		72.1	
SCL e08-MS-10-3-575	10	60	394	110	110	90.2%	575	10	12.9	76.8	180.8
SCL e08-MS-15-3	15	60	394	170	130	91.0%	208-230/460	38.2-37.3/18.7	12.5	76.8	207.3
		50	331	170	120	91.0%	200/400	43.4 / 21.7		72.1	
SCL e08-MS-15-3-575	15	60	394	170	130	91.0%	575	13.9	11	76.8	207.3

Motors include normally closed thermal protector, 1.15 S.F. (60 Hz), tropicalized windings, Class F (B) insulation, and are suitable for use with a VFD (Contact FPZ for pneumatic and speed limits when used with a VFD).

¹Starting current ratio x fla = starting current

²Noise level measured at a distance of 1 m with inlet and outlet ports piped in accordance to ISO 3744

Data is subject to change without notice.

Recommended Accessories

Description	Pressure Safety Valve	Vacuum Safety Valve	Pressure Filter	Vacuum Filter	Check Valve
Part Number	VRL6 (10 HP & 15 HP) ³	VRL6 (15 HP)	FS-231P-300	CT-235P-300C	CV30
	VRL8 (5.5 HP & 7.5 HP) ³	VRL8 (5.5 HP-10 HP)			

³Valve selections are based on 60 Hz and standard air. Valves are supplied uncalibrated. Safety valves are easy to calibrate, but can be ordered with factory calibration.



PRESSURE

VACUUM

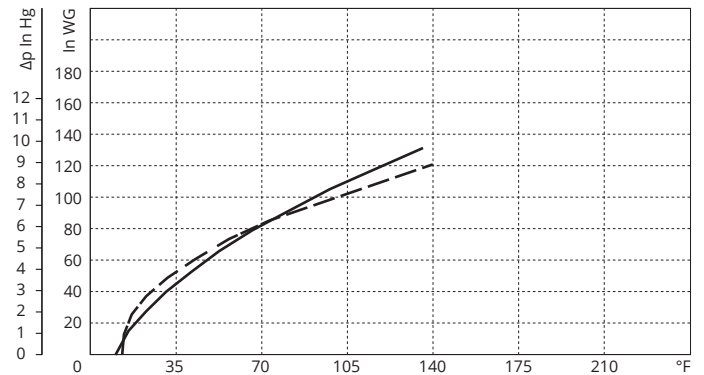
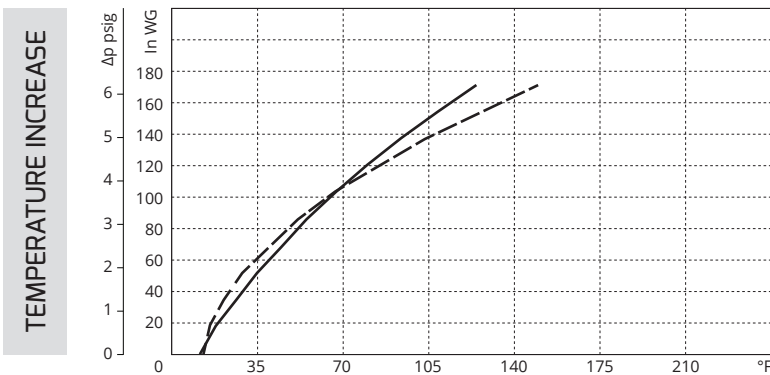
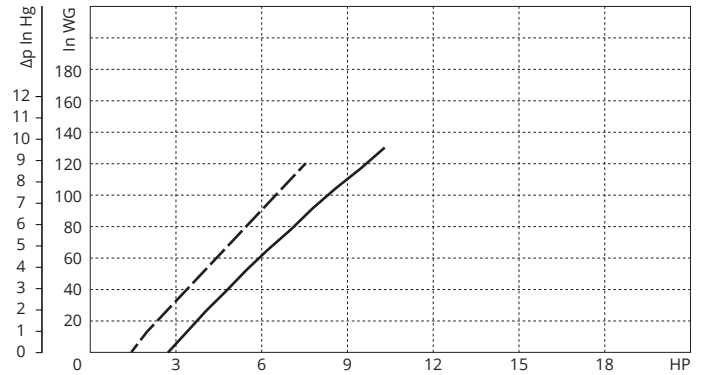
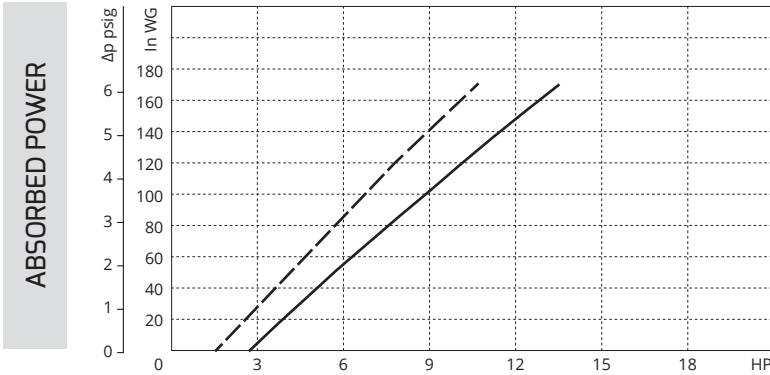
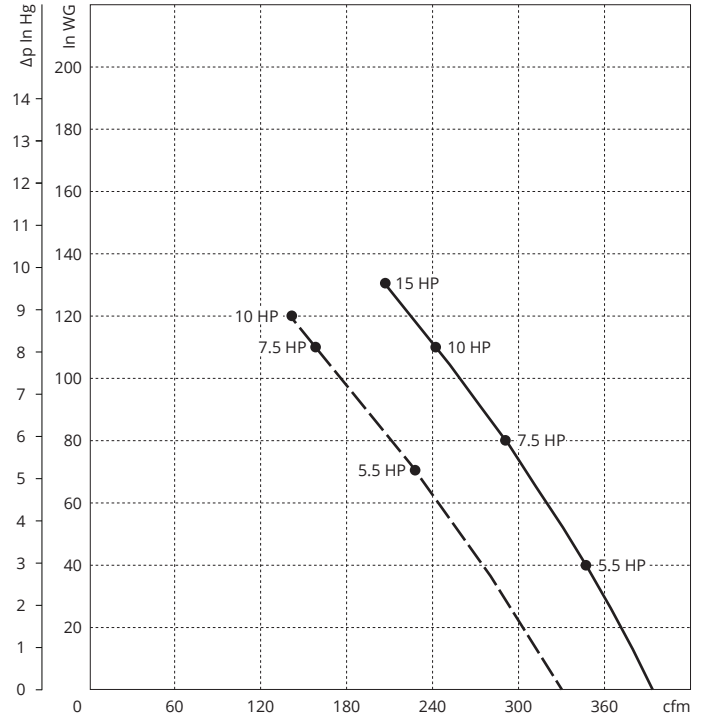
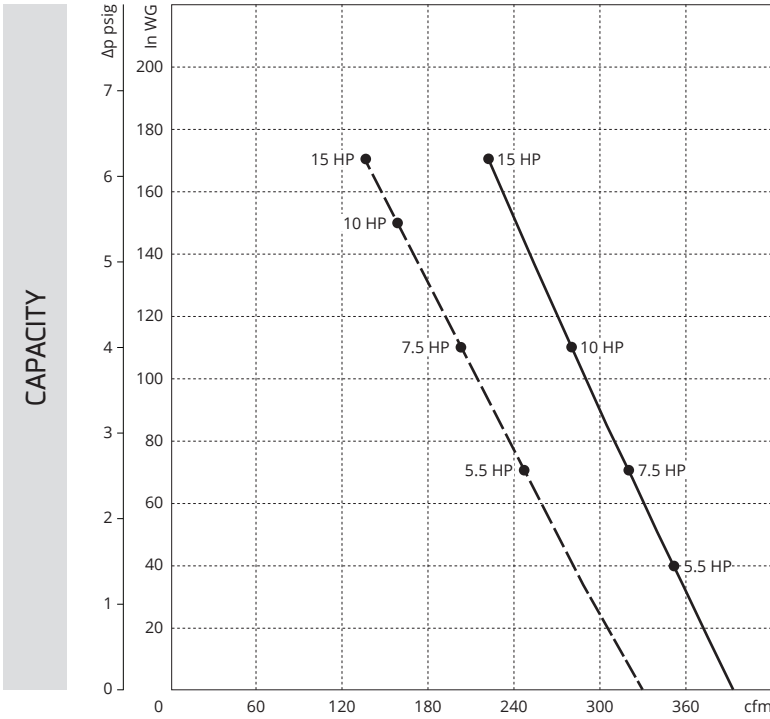

Curves refer to air at 68°F temperature and 29.92 In Hg atmospheric pressure (abs) measured at inlet port. Values for flow, power consumption and temperature rise: +/-10% tolerance. Data subject to change without notice.

KEY --- 50 Hz
 — 60 Hz



**Evolution Series
Technical Characteristics**

- Premium efficient motor
- High efficiency impeller
- Mountable in any position
- Maintenance free operation
- TEFC (IP55)

Optional Features

- Anodized aluminum components for corrosion resistance
- Increased sealing

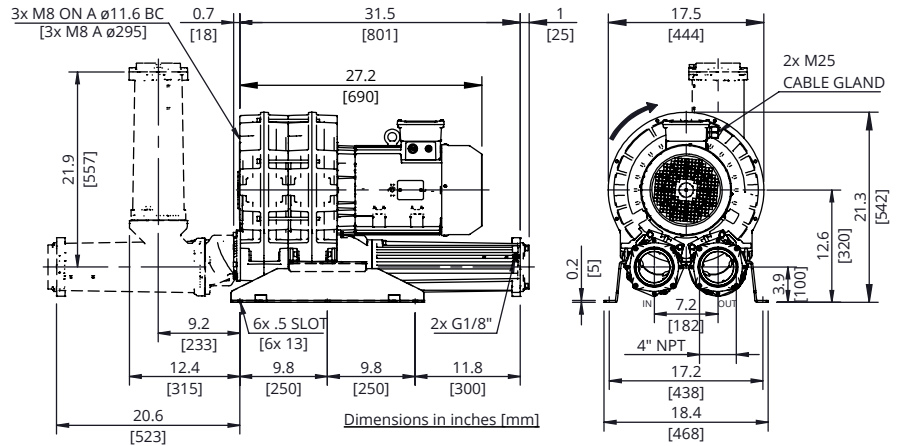

Technical Specifications

Model No.	HP	Hz	Open Flow (cfm)	Max Pressure in. H ₂ O	Max Vacuum in. H ₂ O	Efficiency	Voltage	FLA	Starting Current Ratio ¹	dB(A) ²	Weight (lb)
SCL e07-TS-7.5-3	7.5	60	582	30	30	89.5%	208-230/460	19.8-19.5/9.75	13.7	77.0	249.1
		50	491	60	60	89.2%	200/400	22.2/11.1		73.0	
SCL e07-TS-7.5-3-575	7.5	60	582	50	30	89.5%	575	7.21	13.5	77.0	249.1
SCL e07-TS-10-3	10	60	582	50	60	90.2%	208-230/460	26.1-25/12.5	13	77.0	260.1
		50	491	80	90	90.1%	200/400	28.6/14.3		73.0	
SCL e07-TS-10-3-575	10	60	582	50	60	90.2%	575	10	12.9	77.0	260.1
SCL e07-TS-15-3	15	60	582	100	110	91.0%	208-230/460	38.2-37.3/18.7	12.5	77.0	273.4
		50	491	130	-	91.0%	200/400	43.4 / 21.7		73.0	
SCL e07-TS-15-3-575	15	60	582	100	110	91.0%	575	13.9	11	77.0	273.4

Motors include normally closed thermal protector, 1.15 S.F. (60 Hz), tropicalized windings, Class F (B) insulation, and are suitable for use with a VFD (Contact FPZ for pneumatic and speed limits when used with a VFD).

¹Starting current ratio x fla = starting current

²Noise level measured at a distance of 1 m with inlet and outlet ports piped in accordance to ISO 3744

Data is subject to change without notice.

Recommended Accessories

Description	Pressure Safety Valve	Vacuum Safety Valve	Pressure Filter	Vacuum Filter	Check Valve
Part Number	VRL8 (15 HP) ³	VRL8 (15 HP) ³	FS-245P-400	CSL-2541P-400I	CV40
	VRL9 (5.5 HP - 10 HP) ³	VRL9 (5.5 HP-10 HP) ³			

³Valve selections are based on 60 Hz and standard air. Valves are supplied uncalibrated. Safety valves are easy to calibrate, but can be ordered with factory calibration.



PRESSURE

VACUUM

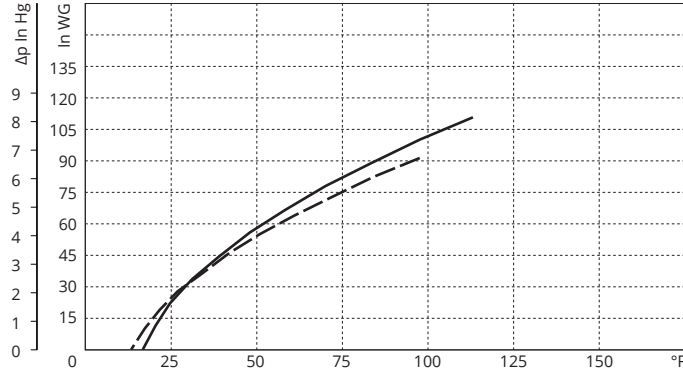
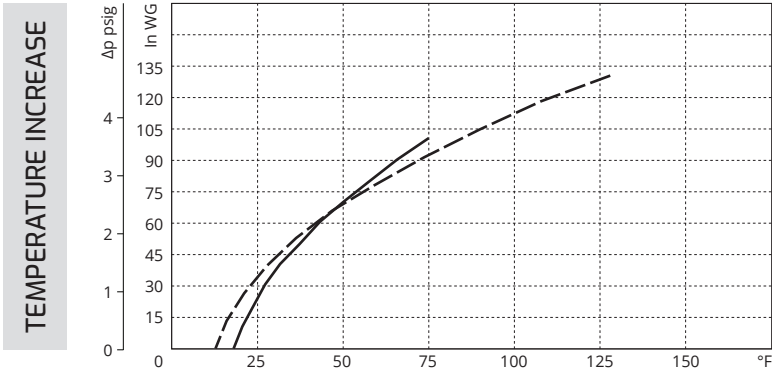
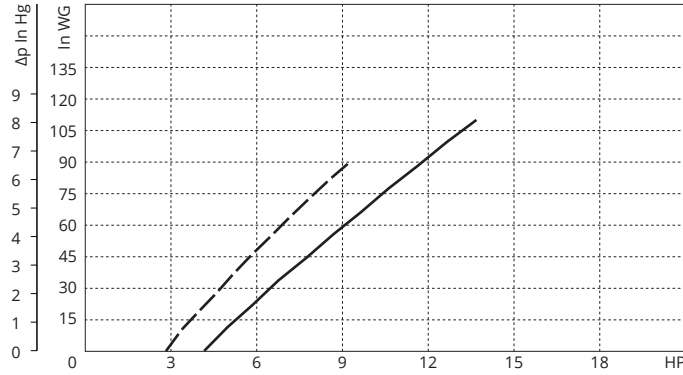
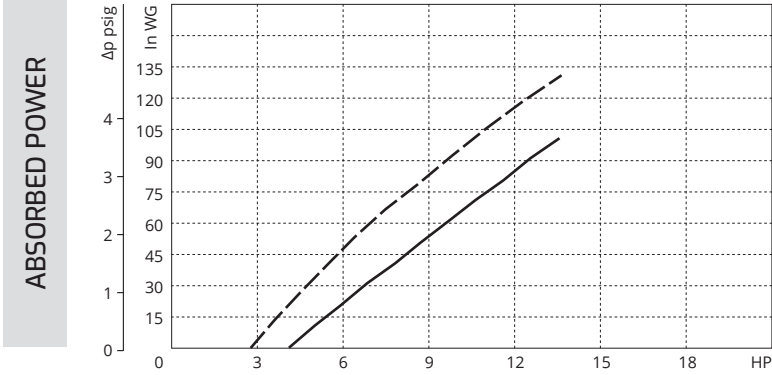
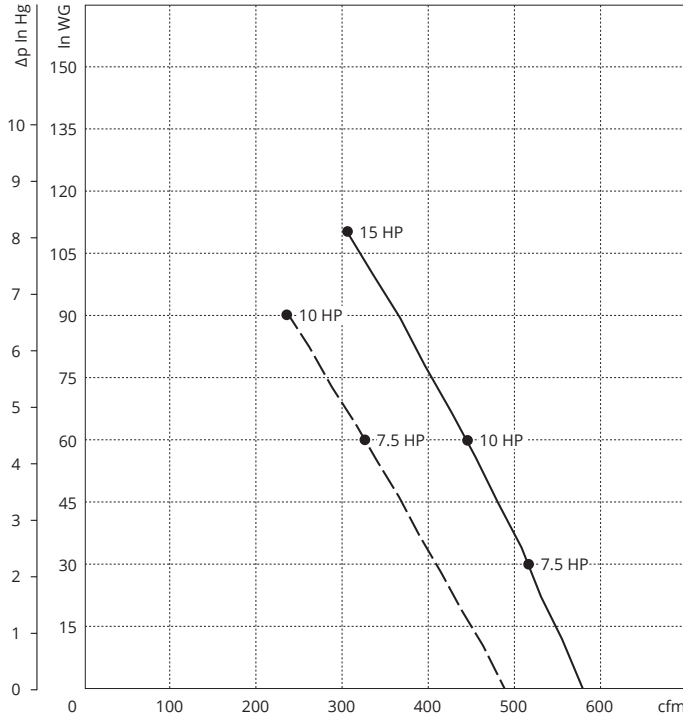
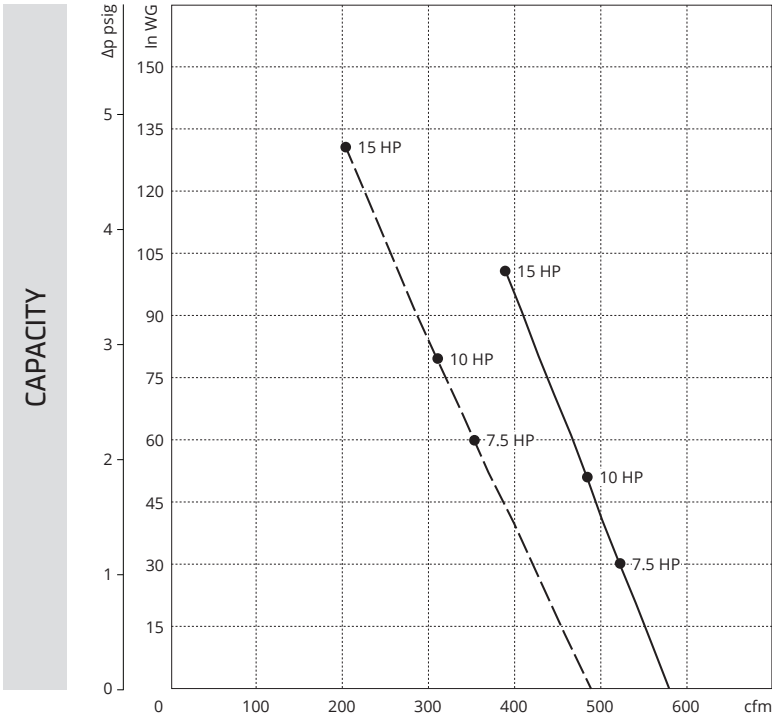

Curves refer to air at 68°F temperature and 29.92 In Hg atmospheric pressure (abs) measured at inlet port.
Values for flow, power consumption and temperature rise: +/-10% tolerance.
Data subject to change without notice.

KEY --- 50 Hz
 — 60 Hz

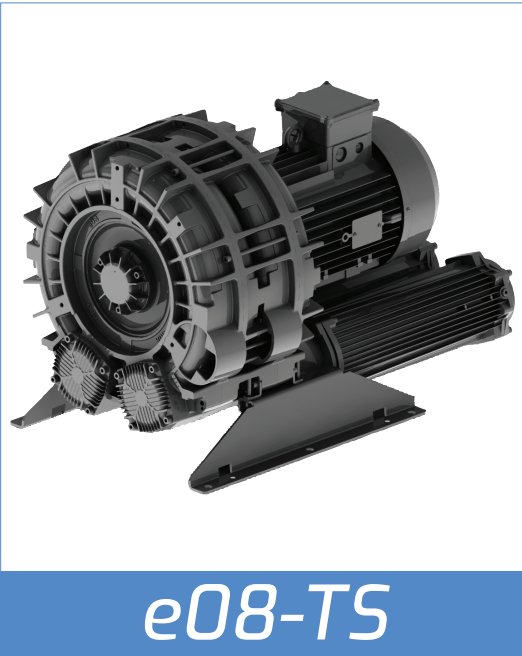

**Evolution Series
Technical Characteristics**

- Premium efficient motor
- High efficiency impeller
- Mountable in any position
- Maintenance free operation
- TEFC (IP55)

Optional Features

- Anodized aluminum components for corrosion resistance
- Increased sealing

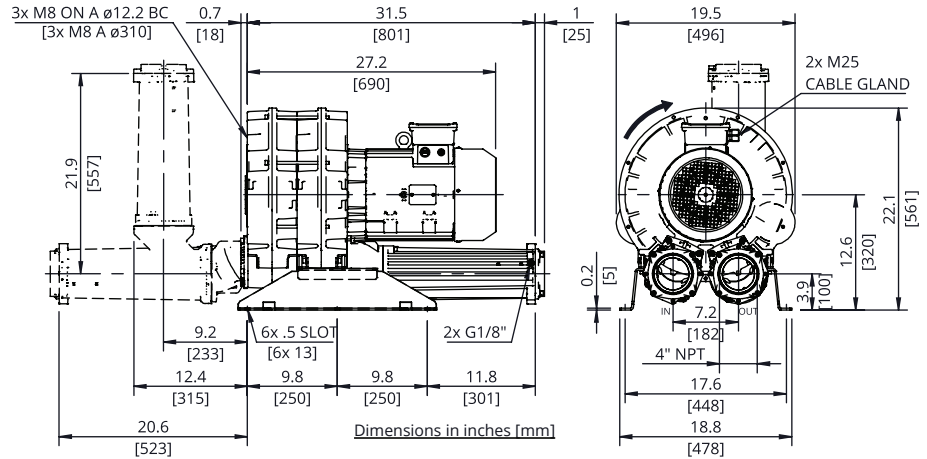

Technical Specifications

Model No.	HP	Hz	Open Flow (cfm)	Max Pressure in. H ₂ O	Max Vacuum in. H ₂ O	Efficiency	Voltage	FLA	Starting Current Ratio ¹	dB(A) ²	Weight (lb)
SCL e08-TS-15-3	25	60	712	60	60	91.0%	208-230/460	38.2-37.3/18.7	12.5	83.3	293.2
		50	593	90	90	91.2%	200/400	43.4/21.7		81.3	
SCL e08-TS-15-3-575	25	60	712	60	60	91.0%	575	13.9	11	83.3	293.2

Motors include normally closed thermal protector, 1.15 S.F. (60 Hz), tropicalized, Class F (B) insulation, and are suitable for use with VFD (Contact FPZ for pneumatic and speed limits when used with a VFD).

¹Starting current ratio x fla = starting current

²Noise level measured at a distance of 1 m with inlet and outlet ports piped in accordance to ISO 3744

Data is subject to change without notice.

Recommended Accessories

Description	Pressure Safety Valve	Vacuum Safety Valve	Pressure Filter	Vacuum Filter	Check Valve
Part Number	VRL9 ³	VRL9 ³	FS-245P-400	CSL-2541-400I	CV40

³Valve selections are based on 60 Hz and standard air. Valves are supplied uncalibrated. Safety valves are easy to calibrate, but can be ordered with factory calibration.



PRESSURE

VACUUM

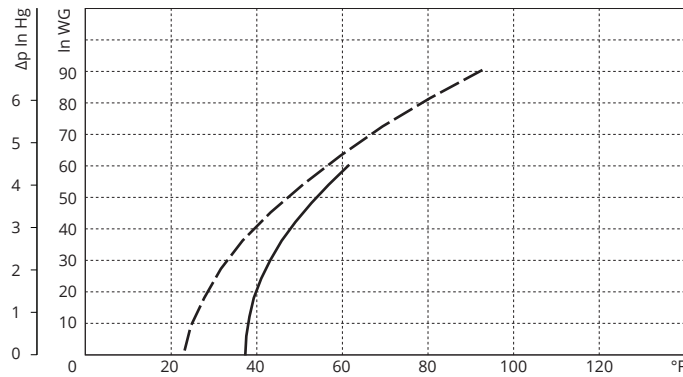
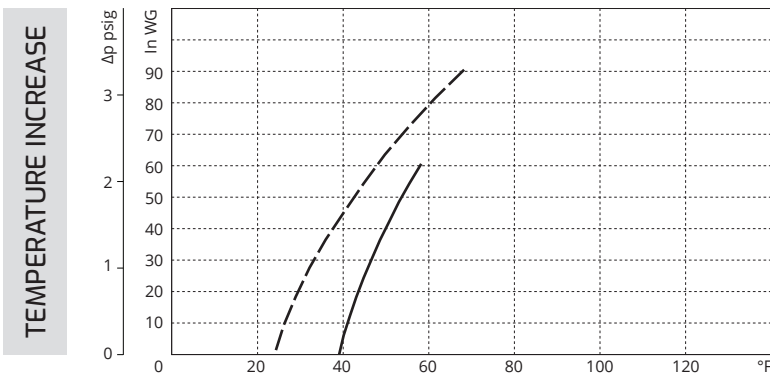
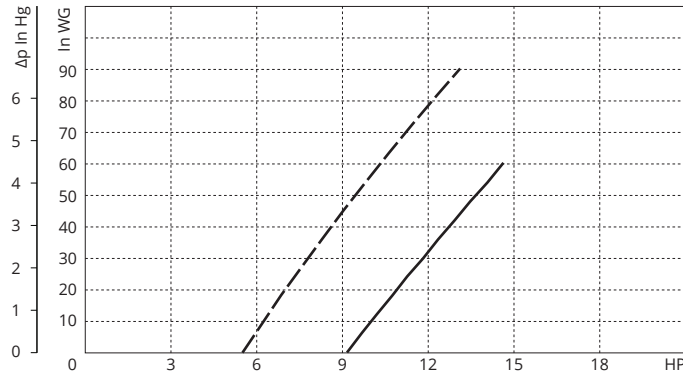
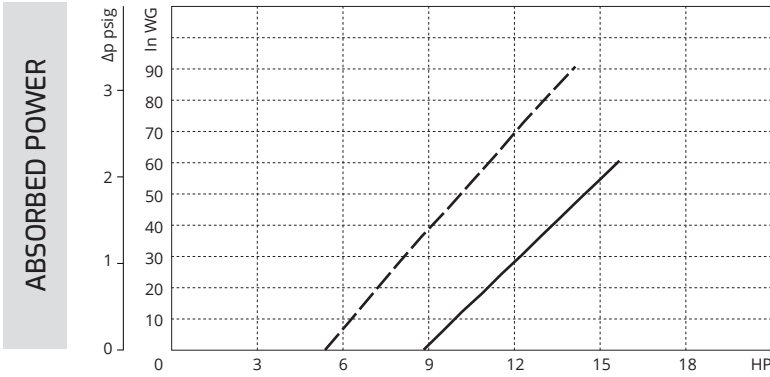
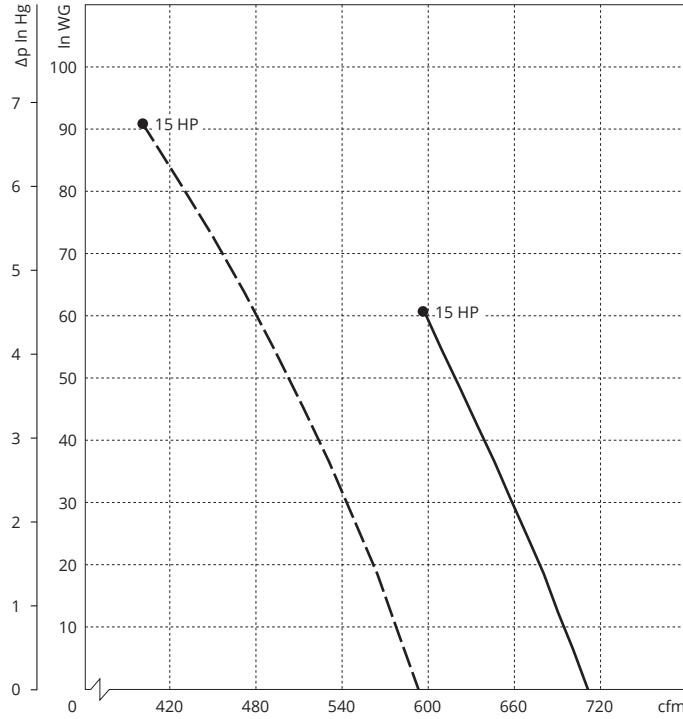
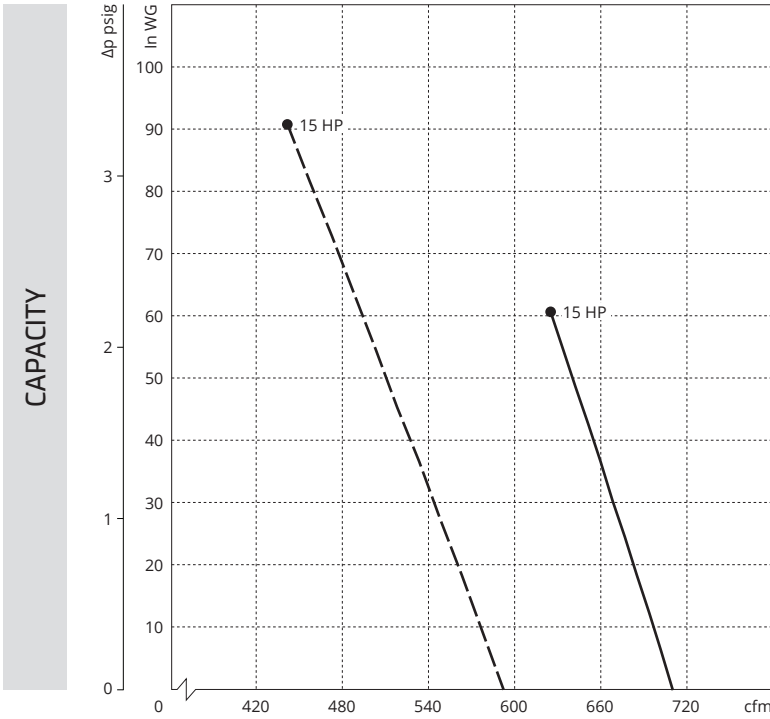

Curves refer to air at 68°F temperature and 29.92 In Hg atmospheric pressure (abs) measured at inlet port. Values for flow, power consumption and temperature rise: +/-10% tolerance. Data subject to change without notice.

KEY

- 50 Hz
- 60 Hz



**Evolution Series
Technical Characteristics**

- Premium efficient motor
- High efficiency impeller
- Mountable in any position
- Maintenance free operation
- TEFC (IP55)

Optional Features

- Anodized aluminum components for corrosion resistance
- Increased sealing

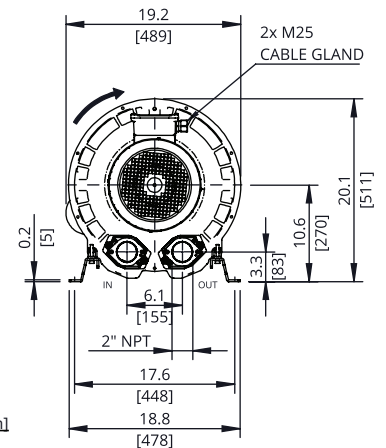
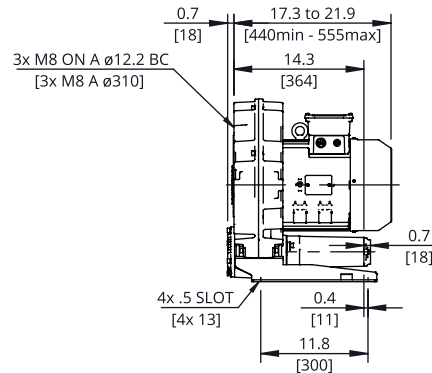

Dimensions in inches [mm]

Technical Specifications

Model No.	HP	Hz	Open Flow (cfm)	Max Pressure in. H ₂ O	Max Vacuum in. H ₂ O	Efficiency	Voltage	FLA	Starting Current Ratio ¹	dB(A) ²	Weight (lb)
SCL e08-MD-5.5-3	5.5	60	177	60	90	88.5%	208-230/460	14.6-15.1/7.55	11.1	78	145.5
		50	150	140	150	88.1%	200/400	17.7/8.86		73	
SCL e08-MD-5.5-3-575	5.5	60	177	60	90	88.5%	575	5.31	10.9	78	145.5
SCL e08-MD-7.5-3	7.5	60	177	140	160	89.5%	208-230/460	19.8-19.5/9.75	13.7	78	182.5
		50	150	200	180	89.2%	200/400	22.2/11.1		73	
SCL e08-MD-7.5-3-575	7.5	60	177	140	160	89.5%	575	7.21	13.5	78	182.5
SCL e08-MD-10-3	10	60	177	200	180	90.2%	208-230/460	26.1-25 / 12.5	13	78	196.2
		50	150	260	—	90.1%	200/400	28.6/14.3		73	
SCL e08-MD-10-3-575	10	60	177	200	180	90.2%	575	10	12.9	78	196.2
SCL e08-MD-15-3	15	60	177	260	—	91.0%	208-230/460	38.2-37.3/18.7	12.5	78	211.6
		50	150	—	—	91.0%	200/400	43.4 / 21.7		73	
SCL e08-MD-15-3-575	15	60	177	260	—	91.0%	575	13.9	11	78	211.6

Motors include normally closed thermal protector, 1.15 S.F. (60 Hz), tropicalized windings, Class F (B) insulation, and are suitable for use with a VFD (Contact FPZ for pneumatic and speed limits when used with a VFD).

¹Starting current ratio x fla = starting current

²Noise level measured at a distance of 1 m with inlet and outlet ports piped in accordance to ISO 3744

Data is subject to change without notice.

Recommended Accessories

Description	Pressure Safety Valve	Vacuum Safety Valve	Pressure Filter	Vacuum Filter	Check Valve
Part Number	VRL6 (5.5 hp - 10 hp) ³ VRL6-HP (15 hp) ³	VRL6	FS-231P-300	CT-235P-300C	CV30

³Valve selections are based on 60 Hz and standard air. Valves are supplied uncalibrated. Safety valves are easy to calibrate, but can be ordered with factory calibration.



PRESSURE

VACUUM

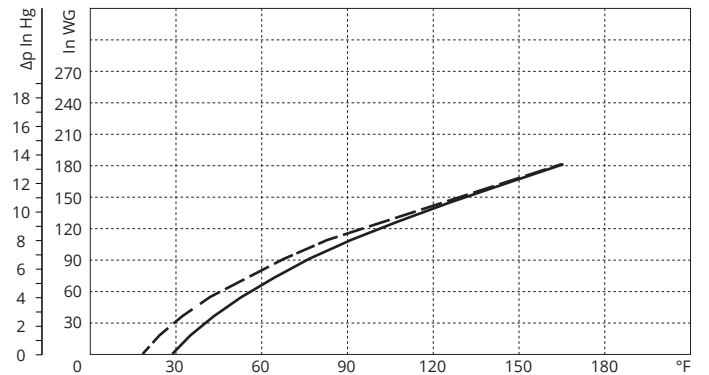
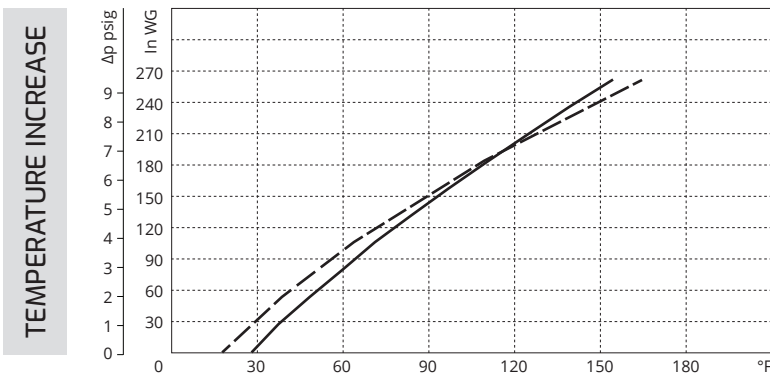
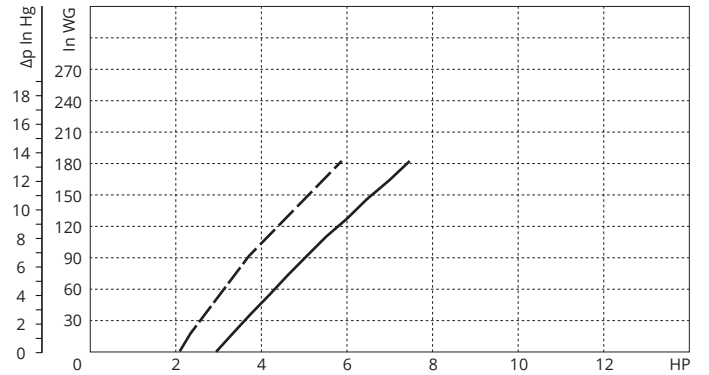
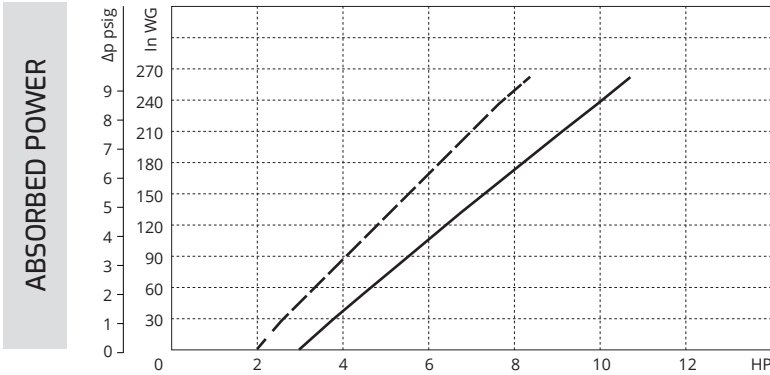
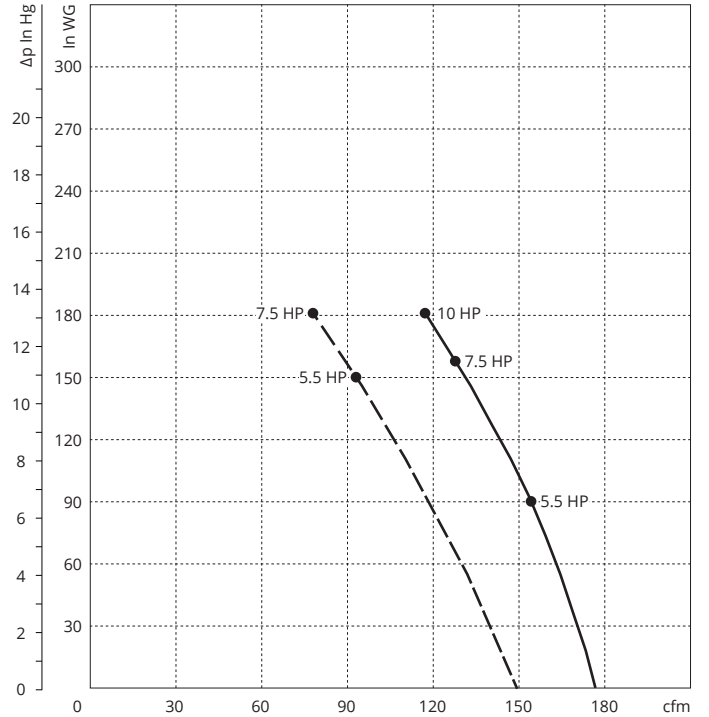
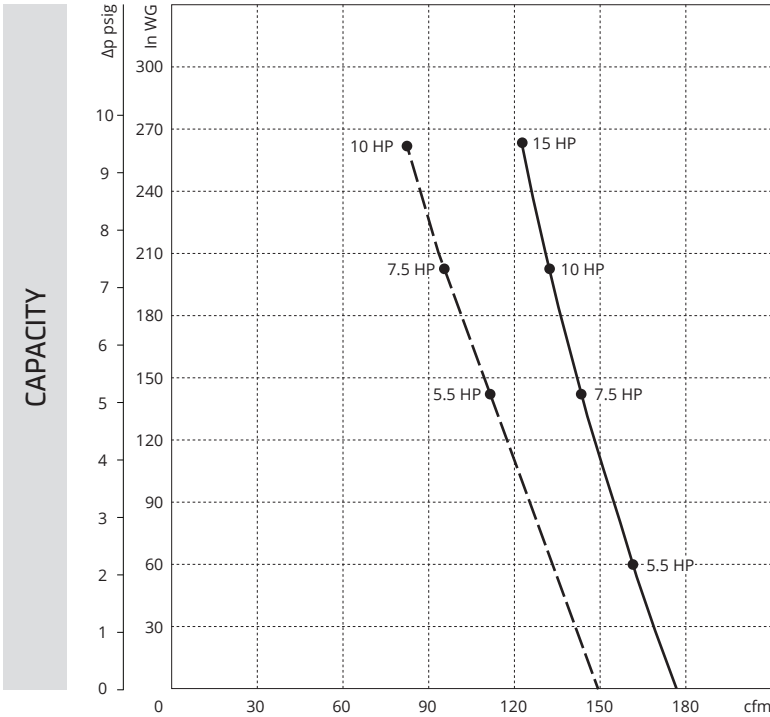

Curves refer to air at 68°F temperature and 29.92 In Hg atmospheric pressure (abs) measured at inlet port.
 Values for flow, power consumption and temperature rise: +/-10% tolerance.
 Data subject to change without notice.

KEY --- 50 Hz
 — 60 Hz



e07-TD

**Evolution Series
Technical Characteristics**

- Premium efficient motor
- High efficiency impeller
- Mountable in any position
- Maintenance free operation
- TEFC (IP55)

Optional Features

- Anodized aluminum components for corrosion resistance
- Increased sealing

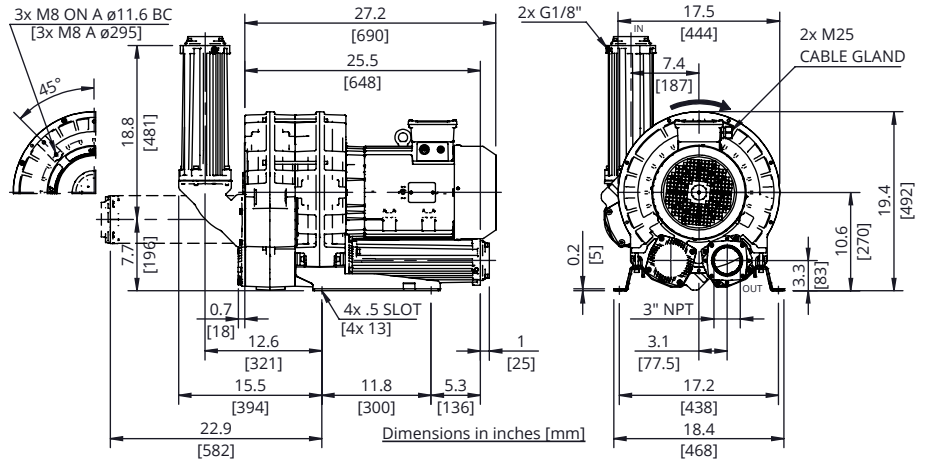

Technical Specifications

Model No.	HP	Hz	Open Flow (cfm)	Max Pressure in. H ₂ O	Max Vacuum in. H ₂ O	Efficiency	Voltage	FLA	Starting Current Ratio ¹	dB(A) ²	Weight (lb)
SCL e07-TD-15-3	15	60	304	220	170	91.0%	208-230/460	38.2-37.3/18.7	12.5	77.0	262.3
		50	255	220	160	91.2%	200/400	43.4/21.7		74.0	
SCL e07-TD-15-3-575	15	60	304	220	170	91.0%	575	13.9	11	77.0	262.3

Motors include normally closed thermal protector, 1.15 S.F. (60 Hz), tropicalized, Class F (B) insulation, and are suitable for use with VFD (Contact FPZ for pneumatic and speed limits when used with a VFD).

¹Starting current ratio x fla = starting current

²Noise level measured at a distance of 1 m with inlet and outlet ports piped in accordance to ISO 3744

Data is subject to change without notice.

Recommended Accessories

Description	Pressure Safety Valve	Vacuum Safety Valve	Pressure Filter	Vacuum Filter	Check Valve
Part Number	VRL6 ³	VRL6 ³	FS-235P-300	CT-235P-300C	CV30

³Valve selections are based on 60 Hz and standard air. Valves are supplied uncalibrated. Safety valves are easy to calibrate, but can be ordered with factory calibration.



PRESSURE

VACUUM

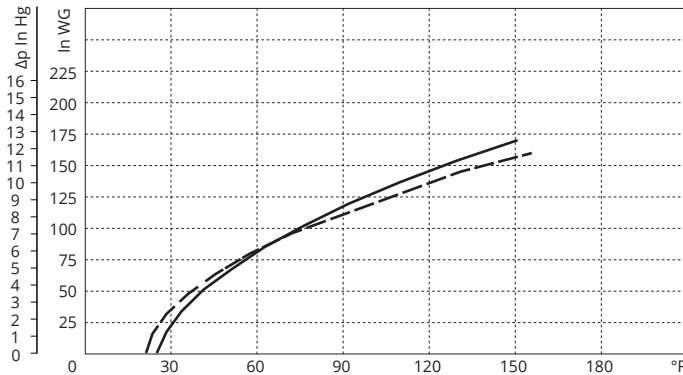
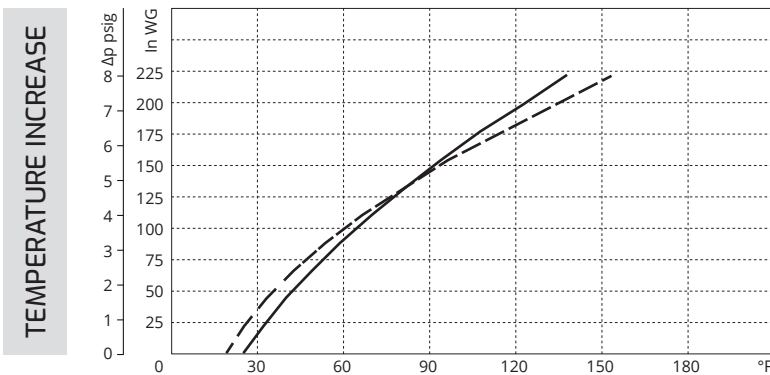
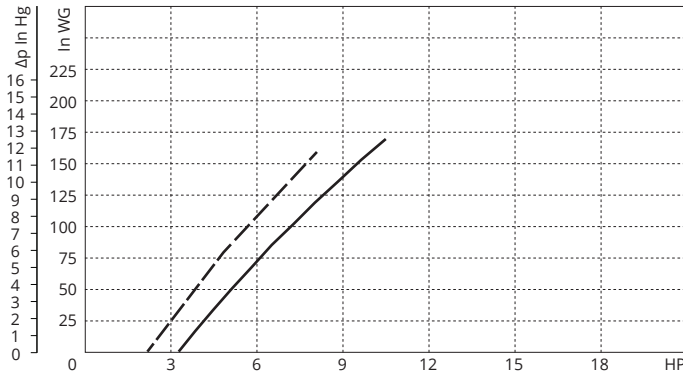
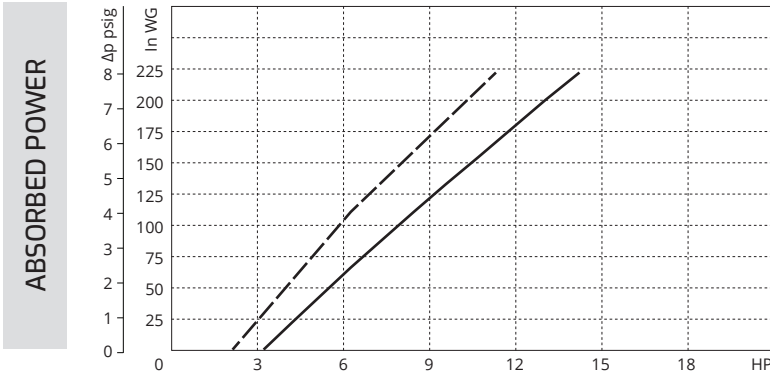
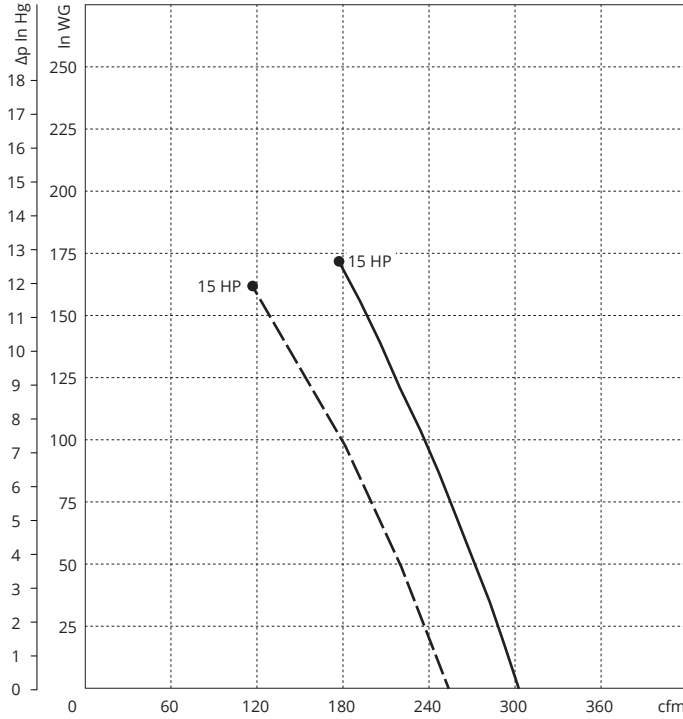
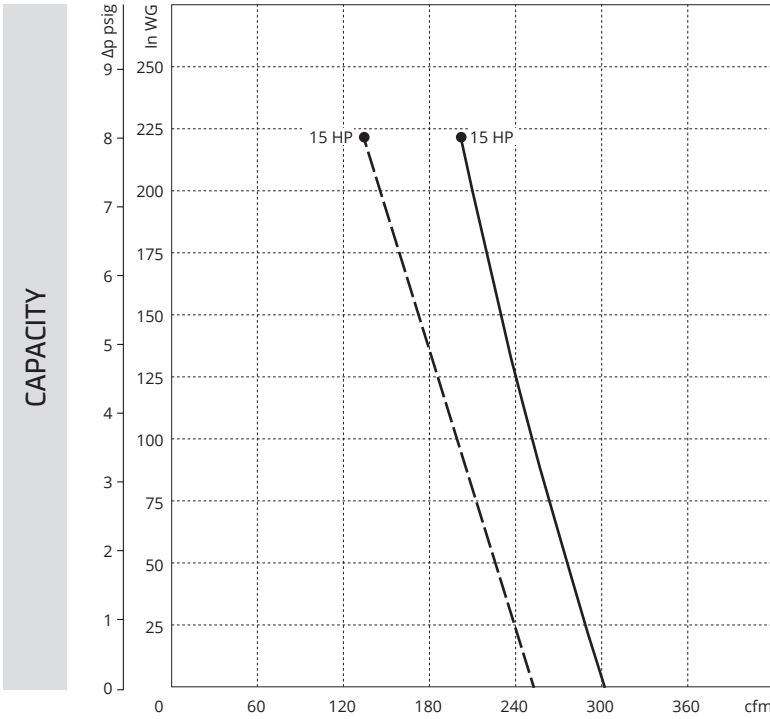

Curves refer to air at 68°F temperature and 29.92 In Hg atmospheric pressure (abs) measured at inlet port.
 Values for flow, power consumption and temperature rise: +/-10% tolerance.
 Data subject to change without notice.

KEY - - - 50 Hz
 ——— 60 Hz



Evolution Series Technical Characteristics

- Premium efficient motor
- High efficiency impeller
- Mountable in any position
- Maintenance free operation
- TEFC (IP55)

Optional Features

- Anodized aluminum components for corrosion resistance
- Increased sealing

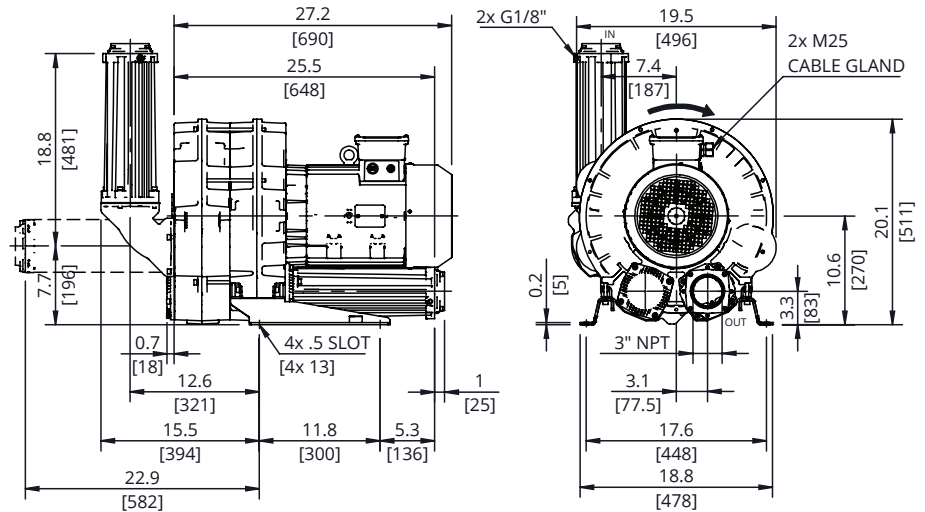

e08-TD

Technical Specifications

Model No.	HP	Hz	Open Flow (cfm)	Max Pressure in. H ₂ O	Max Vacuum in. H ₂ O	Efficiency	Voltage	FLA	Starting Current Ratio ¹	dB(A) ²	Weight (lb)
SCL e08-TD-15-3	15	60	406	160	170	91.0%	208-230/460	38.2-37.3/18.7	12.5	81.5	277.8
		50	340	220	170	91.2%	200/400	43.4/21.7		79.5	
SCL e08-TD-15-3-575	15	60	406	160	170	91.0%	575	13.9	11	81.5	277.8

Motors include normally closed thermal protector, 1.15 S.F. (60 Hz), tropicalized, Class F (B) insulation, and are suitable for use with VFD (Contact FPZ for pneumatic and speed limits when used with a VFD).

¹Starting current ratio x fla = starting current

²Noise level measured at a distance of 1 m with inlet and outlet ports piped in accordance to ISO 3744

Data is subject to change without notice.

Recommended Accessories

Description	Pressure Safety Valve	Vacuum Safety Valve	Pressure Filter	Vacuum Filter	Check Valve
Part Number	VRL6 ³	VRL6 ³	FS-235P-300	CT-235P-300C	CV30

³Valve selections are based on 60 Hz and standard air. Valves are supplied uncalibrated. Safety valves are easy to calibrate, but can be ordered with factory calibration.



PRESSURE

VACUUM

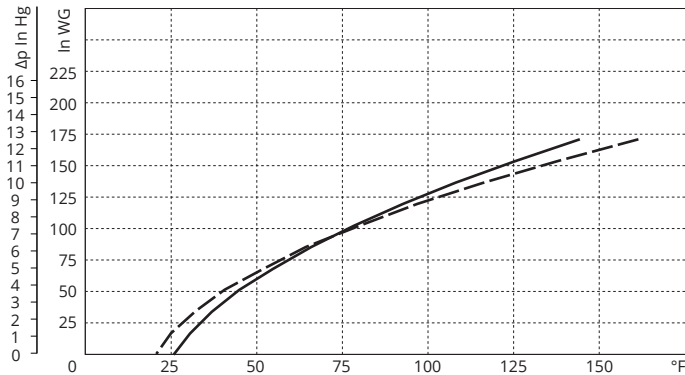
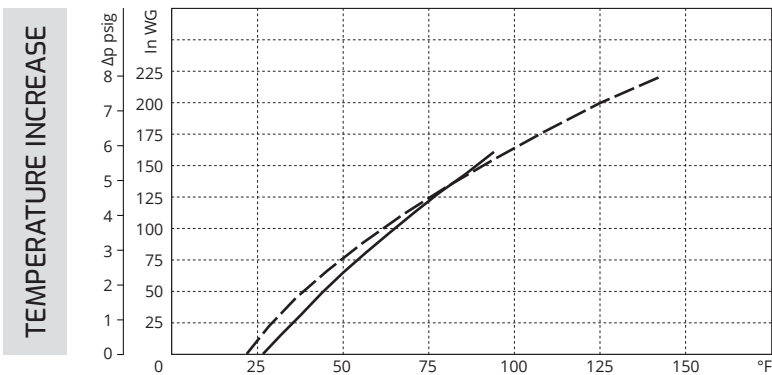
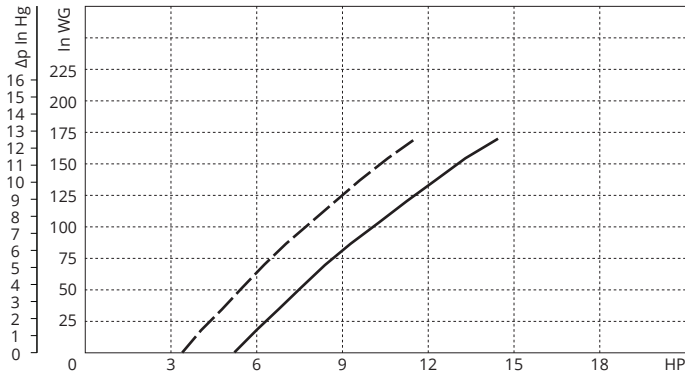
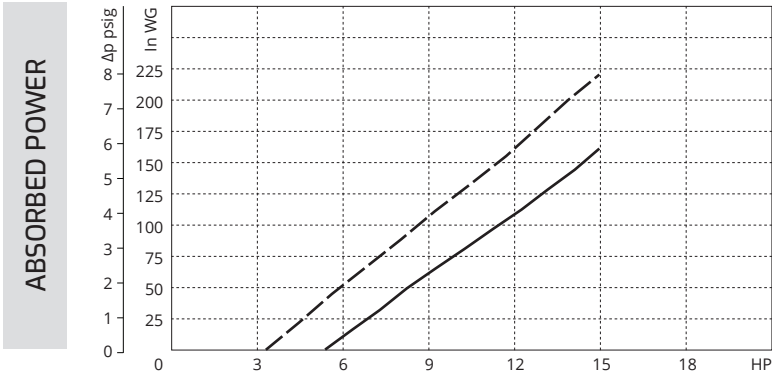
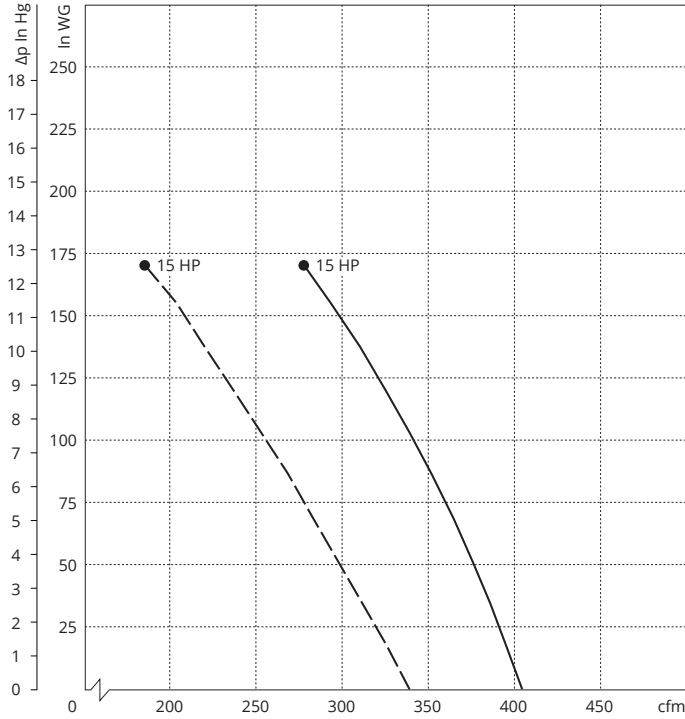
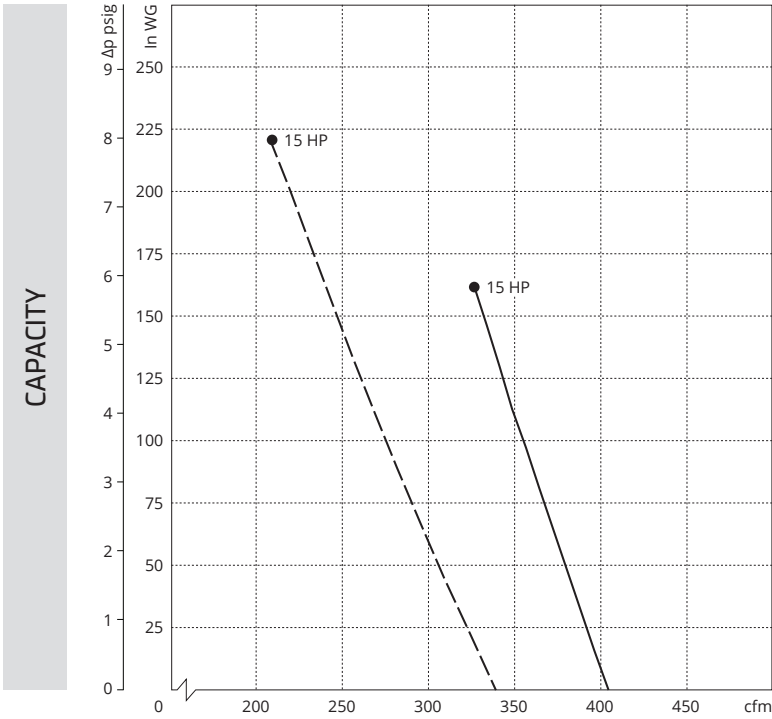

Curves refer to air at 68°F temperature and 29.92 In Hg atmospheric pressure (abs) measured at inlet port.
 Values for flow, power consumption and temperature rise: +/-10% tolerance.
 Data subject to change without notice.

KEY --- 50 Hz
 ——— 60 Hz

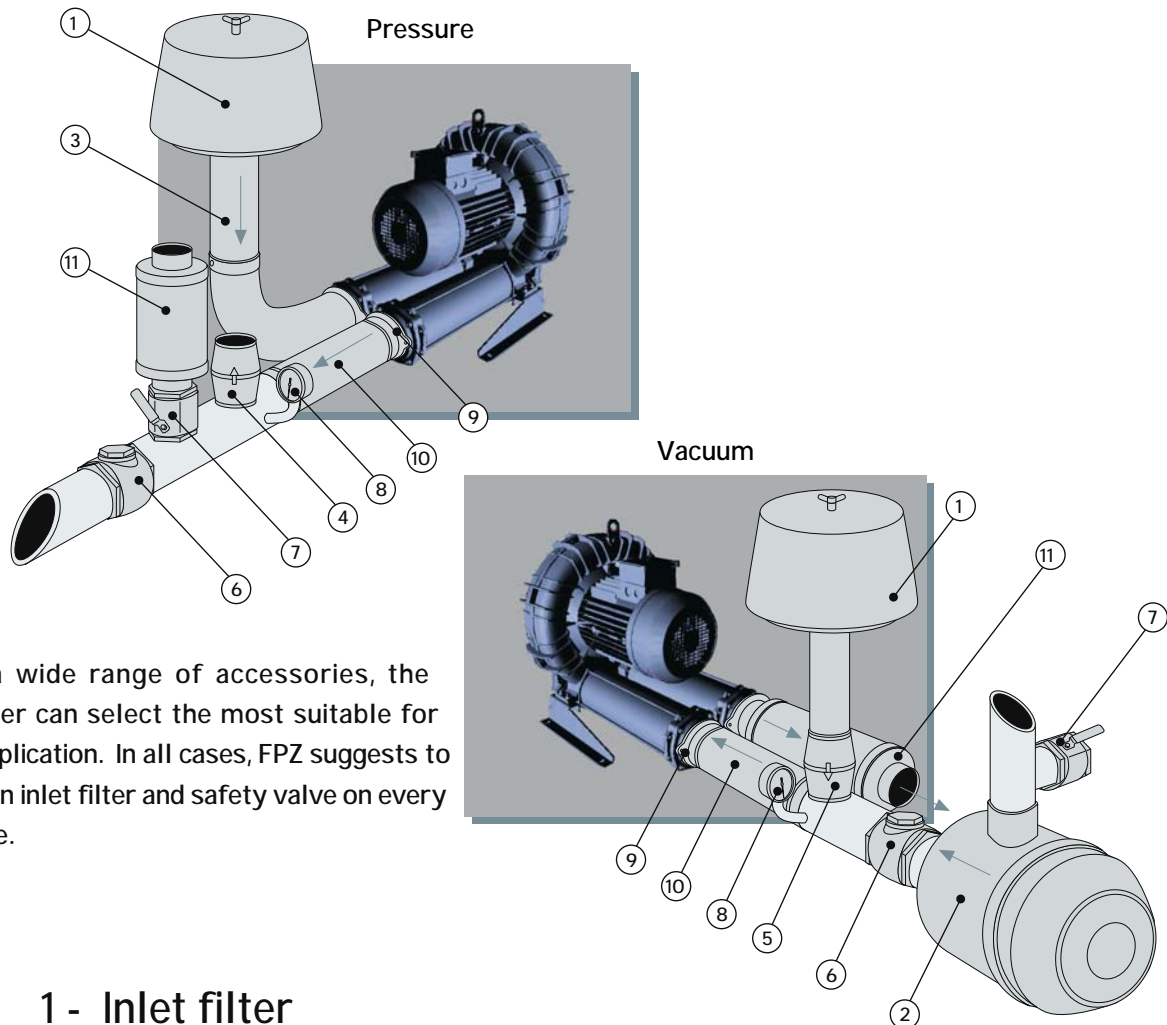

From a wide range of accessories, the customer can select the most suitable for their application. In all cases, FPZ suggests to install an inlet filter and safety valve on every machine.

- 1 - Inlet filter
- 2 - Inline filter
- 3 - Filter manifold
- 4 - Safety valve (pressure)
- 5 - Safety valve (vacuum)
- 6 - Check valve
- 7 - Ball valve (used to control flow by bleeding air)
- 8 - Pressure / Vacuum gauge
- 9 - Sleeve (for hose connection)
- 10 - Flexible hose
- 11 - Additional silencer



The VRL valves are designed to protect blowers and / or motors from over pressurization or excess vacuum. When there is over pressurization, the valve opens and discharges to the outside. When there is excess in vacuum, the valve opens and takes flow from outside.

The valves have been designed for low pressure / low vacuum, with minimal difference between the initial value at which the valve begins to open and its fully opened position. The valves are supplied with 2 different springs to maximize their efficiency. These compact valves, made of aluminum alloy, are both easy to install and calibrate, and operate in a wide range of capacities. The VRL can be plumbed to divert excess primary flow through a secondary external outlet when working in pressure conditions, or to pipe in a secondary flow when working in vacuum.

"HP" valves are used for pressures >240" H2O.

Maximum efficiency is achieved by keeping operating values (flow versus pressure or vacuum) within the operating range (shaded area on graph). Capacity refers to air having a density equal to 0.075 lbs./cu.ft .



VRL6
VRL6 HP

VRL8
VRL8 HP

VRL9

OPERATING RANGE

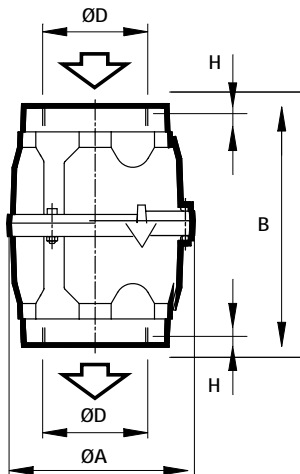
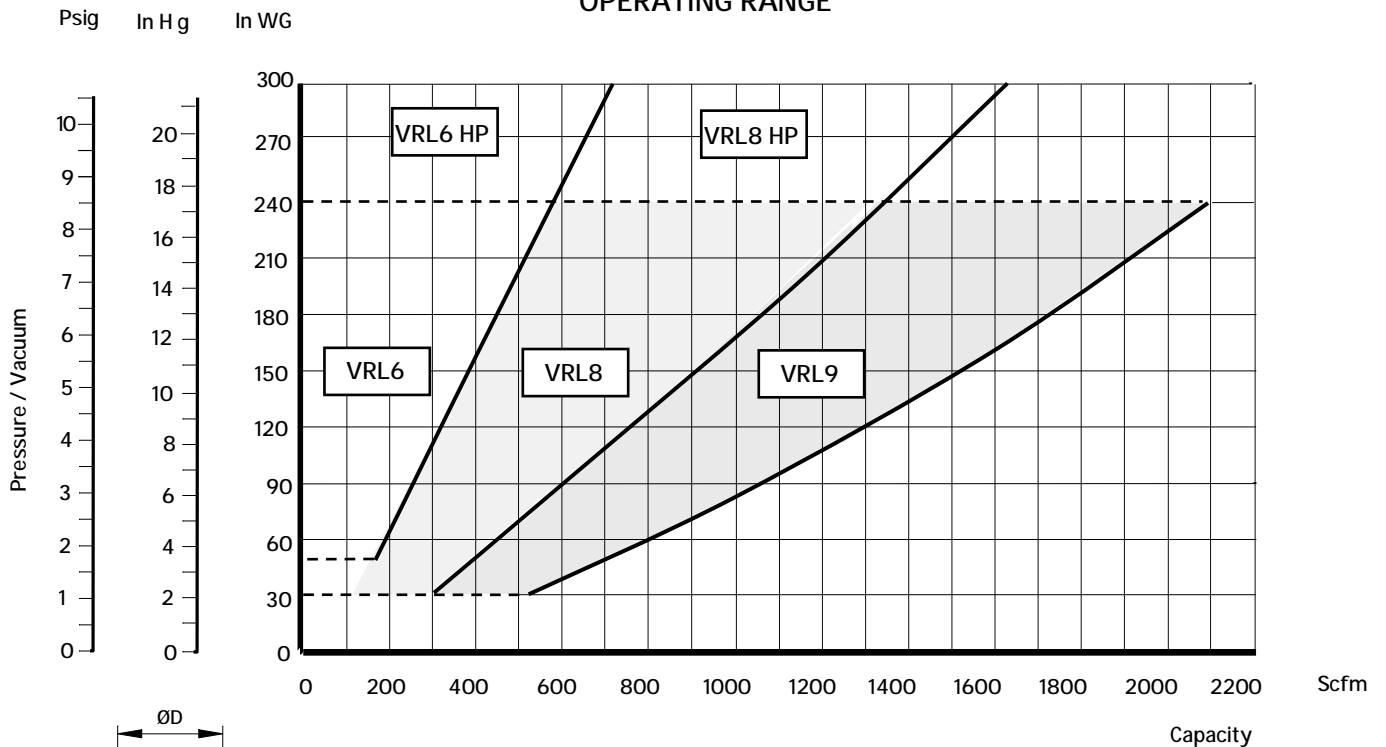

OVERALL DIMENSIONS

TYPE	ND	D	A	B	H	WEIGHT (Lbs)
VR6 & VRL6 HP	2"	2" NPT	4.02	6.90	0.47	1.9
VRL8 & VRL8HP	3"	3" NPT	5.31	7.48	0.59	4.2
VRL9	4"	4" NPT	6.30	8.11	0.71	5.7

- Dimensions in inches.
- Specifications subject to change without prior notice.

VRL valves are supplied uncalibrated - contact FPZ for calibration options.



FPZ inlet filters are used for pressure applications. The inlet filters combine filtration and sound attenuation into a compact package. Inlet filters consist of a filter cartridge enclosed by a carbon steel weather hood. Elements are easily serviceable by simply removing the weather hood.

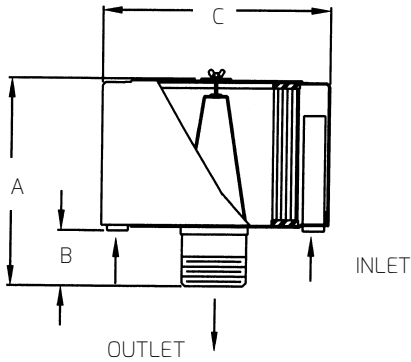

Dimension tolerance $\pm 1/8"$



VG-020-013

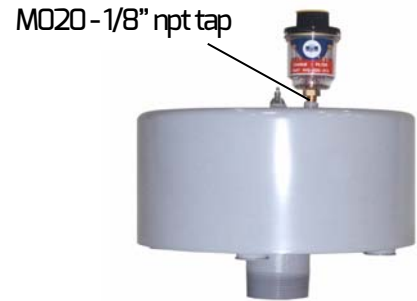

FEATURES & SPECIFICATIONS

- Polyester: 99%+ removal efficiency standard to 5 micron. (Other media available upon request.)
- Fully drawn weather hood - no welds to rust or vibrate apart
- Tubular silencing design - tube is positioned to maximize sound attenuation and air flow while minimizing pressure drop
- Durable carbon steel construction with baked enamel finish
- Filter change out differential: 10"-15" H₂O Over Initial Delta P.

OPTIONAL DIRTY FILTER INDICATOR

The **VG-020-013** dirty filter indicator is used to maximize filter life for pressure applications only. The yellow indicator in the site window drops as dirt accumulates on the filter element. The element is ready for change out or servicing when the yellow indicator reaches the red zone. The filter condition can be determined without removing the weather hood even after the blower has been shut down.

The indicator can be mounted in the inlet piping between the blower and filter or directly to the filter housing by having a 1/8" npt tap installed in the hood. If a tap is required, FPZ part number **M020*** should be ordered.

Polyester Element	NPT	Dimensions (Inches)			Used on Models	Approx Wt. Lbs
		A	B	C		
FS-15-050	1/2"	4	1 1/2	6	10DL	2
FS-15-075	3/4"	4	1 1/2	6	15DH	2
FS-15-100	1"	4	1 1/2	6	06	2
FS-19P-125	1 1/4"	6 5/8"	1 5/8"	6	K03-MS, R20-MD, R30-MD, R40-MD	3
FS-19P-150	1 1/2"	6 5/8"	1 5/8"	6	K04-MS	4
FS-31P-200	2"	7 1/4"	2 1/4"	10	K05-MS, K05-TD	8
FS-231P-200	2"	12 1/4"	2 1/4"	10	K06-MS, K06-TD, K07R-MD, K08R-MD, e07-md, e08-MD	14
FS-231P-300	3"	13"	3"	10"	K07-MS, K05-TS, K07-TD, e07-MS, e07-TD	15
FS-235P-300	3"	13"	3"	16"	K08-MS, K06-TS, K08-TD, e08-MS, e08-TD	29
FS-235P-400	4"	14"	4"	16"	K09-MS, K10-MS, K09-MD, K10-MD, K11-MD, K12-MD, K09-TD, K10-TD	30
FS-245P-400	4"	14"	4"	16"	K07-TS, K08-TS, K11-MS, K12-MS, K11-TD, K12TD, e07-TS, e08-TS	31
FL10**	NA	14 3/8"	1 3/8"	16 3/16"	K09-TS, K10-TS, K11-TS, K12-TS,	18

*M020 1/8" npt filter tap will be added to filter part number suffix if ordered.

**FL10 utilizes 15 micron paper element and does not include tubular silencers. FL10 filters are normally ordered with CA10 manifold



FPZ inline filters are typically used in vacuum applications to prevent debris from entering the blower. Inline filters consist of a metal housing with a metal cover retained by quick - change clamps for easy servicing of the element. Polyester elements are recommended for humid applications.

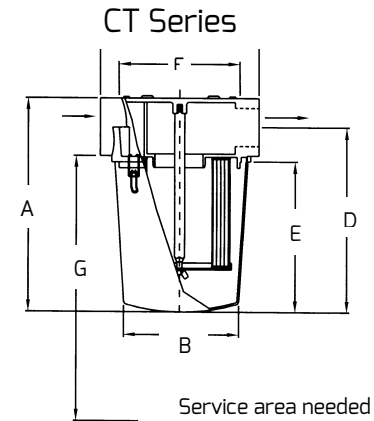
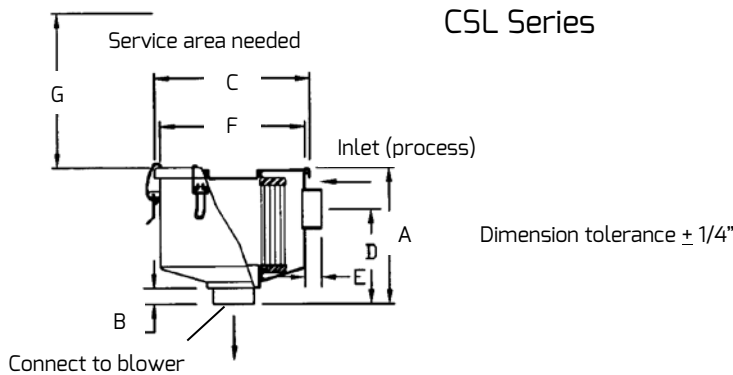

- ♦ Polyester: 99%+ removal efficiency standard to 5 micron
- ♦ Stainless steel torsion clips for durability
- ♦ Rugged construction with powder coated finish
- ♦ Low pressure drop
- ♦ Positive sealing O-ring seal system
- ♦ Large dirt holding capacity and easy field cleaning, (especially when mounted horizontally or inverted)
- ♦ Fully-drawn one piece canister
- ♦ Filter change out differential: 10"-15" H₂O Over Initial Delta P

- ♦ Various media available
- ♦ Epoxy coated housings
- ♦ Special connections
- ♦ Available in Stainless Steel
- ♦ Activated carbon prefilter to reduce odor
- ♦ Alternate Top-to-canister fastening system for low pressure or pulsating systems

Polyester Element	NPT	DIMENSIONS (Inches)							Used on Models	Approx Wt. Lbs
		A	B	C	D	E	F	G		
CSL-843-050HC	1/2"	4 3/8	9/16	5 7/8	2 1/2	9/16	5	3 1/4	10DL	3
CSL-843-075HC	3/4"	4 3/8	9/16	5 7/8	2 1/2	9/16	5	3 1/4	15DH	3
CSL-843-100HC	1"	4 3/8	3/4	5 7/8	2 1/2	3/4	5	3 1/4	06	3
CSL-843-125HC	1 1/4"	4 3/8	3/4	5 7/8	2 1/2	3/4	5	3 1/4	K03-MS, R20-MD	3
CSL-849-125HC	1 1/4"	6 3/4	3/4	7 5/16	4 1/2	3/4	6 13/16	5 1/4	R30-MD, R40-MD	5
CSL-849-150HC	1 1/2"	6 3/4	3/4	7 5/16	4 1/2	3/4	6 13/16	5 1/4	K04-MS	5
CSL-851-200HC	2"	10 1/4	3/4	8 3/4	5	3/4	7 5/8	9 1/4	K05-MS, K06-MS, K05-TD, K06-TD, K07R-MD, K08R MD, e07-MD, e08-MD	15
CT-235P-300C	3"	18 13/16	9 7/8	13 1/2	16 4/5	13 1/8	10	14	K05-TS, K06-TS, K07-MS, K08-MS, K07-TD, K08-TD, e07-MS, e08-MS, e07-TD, e08-TD	30
CT-235P-400C	4"	18 13/16	9 7/8	13 1/2	16 4/5	13 1/8	10	14	K09-MS, K10-MS, K09-MD, K10-MD, K11-MD, K12-MD, K09-TD, K10-TD	29
CSL-2541-400I*	4"	16 3/8	3 5/8	13 1/4	9 1/2	3 1/2	12 1/16	8	K07-TS, K08-TS, e07-TS, e08-TD, K11-MS, K12-MD, K11-TD, K12-TD	38
CT-275P-500C	5"	18 1/4	16	19	14 3/8	9 7/8	14 3/4	20	K09-TS, K10-TS	50
CTD-375P-500C	5"	25 3/8	16	19	21 1/2	17	14 3/4	35	K11-TS, K12-TS	60

* Male x male npt connections
 Dimensions for reference only



Gauges, Check Valves, Silencers, Enclosures

SS2007

Gauges

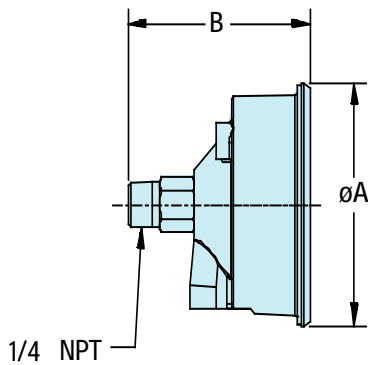

Gauges are important for monitoring the operating pressure or vacuum of the blower. Gauges should be positioned as close to the blower as possible.

Part number	Duty	Scale	A	B
VG25-60	Vacuum	0-60" H ₂ O	2.88	2.59
VG25-200	Vacuum	0-200" H ₂ O		
VG25-300	Vacuum	0-300" H ₂ O		
PG25-60	Pressure	0-60" H ₂ O		
PG25-200	Pressure	0-200" H ₂ O		
PG25-300	Pressure	0-300" H ₂ O		
PG25-15*	Pressure	0-15 psi	2.7	2.25

Dimensions in inches. Tolerance on given values ± 10% - unbinding and can be changed without prior notice.

*PG25-15 is suitable for outdoor use

Check Valves

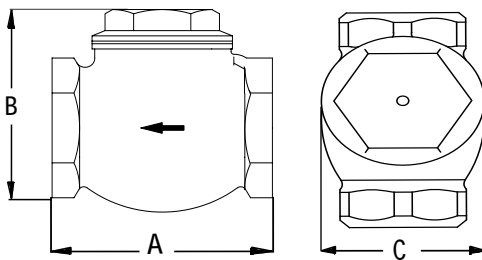

Swing check valves allow air to flow in one direction. These valves prevent backflow into the blower and are supplied in bronze or brass.

Part Number	NPT	A	B	C
CV075	0.75"	2.4		
CV10	1"	2.8	2.7	1.9
CV125	1.25"	3.2	3.2	2.2
CV15	1.5"	3.6	3.5	2.5
CV20	2"	4.3	4.2	3.1
CV30	3"	5.8	6.1	4.2
CV40	4"	6.9	7.1	5.5

Dimensions in inches. Tolerance on given values ± 10% - unbinding and can be changed without prior notice.

Silencers

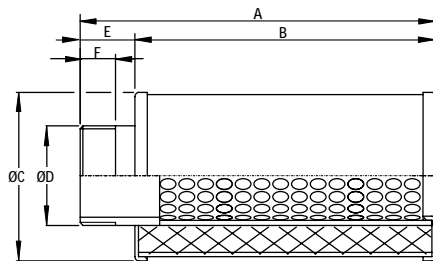

Silencers provide additional sound attenuation.

TYPE	D	A	B	C	E	F	lbs
SS 4	1" 1/4	7.5	5.5	2.8	2	0.6	0.8
SS 5	1" 1/2	7.9	6.7	3.1	1.2	0.8	1.1
SS 6	2"	9.1	7.9	3.5	1.2	0.8	1.3
SS 8	3"	19.1	15.7	6.0	3.3	0.8	4.8
SS 9	4"	18.3	16.9	6.7	1.1	0.8	9.9

Steel manufactured (apart from SI 9 / SS 9 - entirely in aluminium) with sound absorbing polyurethane element.

Dimensions in inches. Tolerance on given values ± 10% - unbinding and can be changed without prior notice.

Sound Enclosures

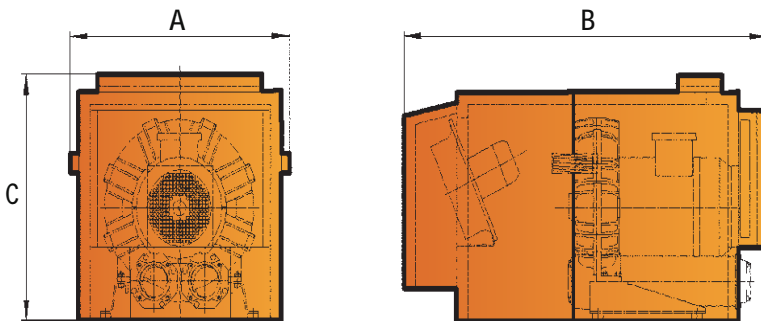

Part #	Used on models	A	B	C
IH1	SCL K03-MS	13.4	18.2	15.8
IH3	SCL K04-MS	14.3	19.7	16.5
IH5	SCL K05-6 MS + 30-40DH	16.9	26.8	21.3
IH7	SCL e+K07-8 MS / MD	31.7	64.4	26
IH8	SCLe+K07-8 TD	31.7	64.4	26
IH9	SCL e+K07-8 TS	31.7	64.4	26
IH10	SCL K09-12 MS/MD	31.7	67.2	30
IH11	SCL K09-10 TD	31.7	67.2	30
IH12	SCL K11-TD	31.7	67.2	30
IH13	SCL K09-11 TS	31.7	67.2	31.5

Dimensions in inches - unbinding and can be changed without prior notice.



FPZ blowers cover a broad pneumatic range ranging from 1/3 to 50 hp. In addition to models listed in this catalog, FPZ is also able to provide a variety of specialty blowers including gas tight, explosion proof, ATEX, belt driven, direct coupled, and more.

All FPZ blowers feature several technical advantages including:

Quiet Operation due to a unique internal design that channels air into our sound absorbing foams along with sealing throughout the blower.

Low Power consumption thanks to FPZ's impeller design, multiple power options, and efficient electric motors. FPZ can generally provide more air with less power.

Quality has been a part of FPZ since our foundation. All blowers are 100% tested before they leave our factory and are backed by our 3-YEAR WARRANTY. FPZ SpA is an ISO 9001 certified company.





volution



FPZ Inc

150 N. Progress Drive - Saukville, WI 53080 U.S.A.
Tel. (262) 268-0180 - Fax (262) 268-0415 - usa@fpz.com