



designs

# DESIGNS

MS

Single impeller single stage

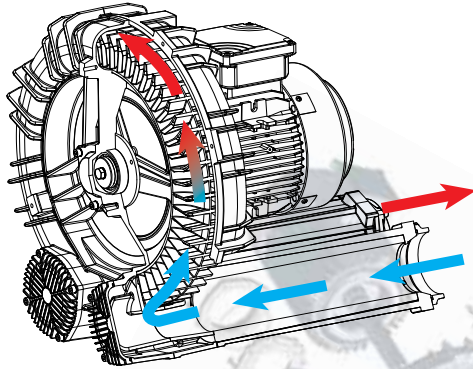

TS

Twin impeller single stage

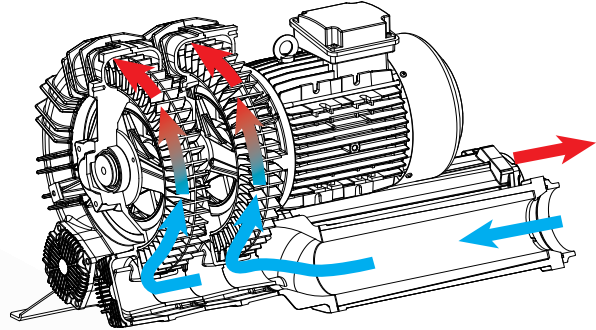

MD

Single impeller double stage

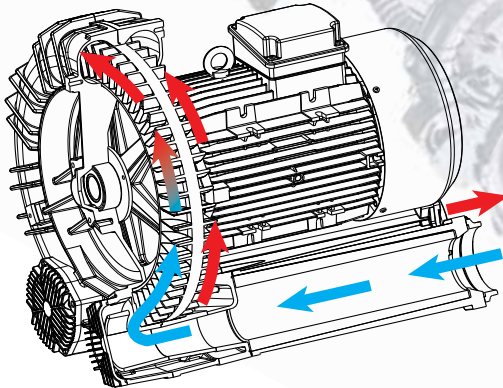

TD

Twin impeller double stage

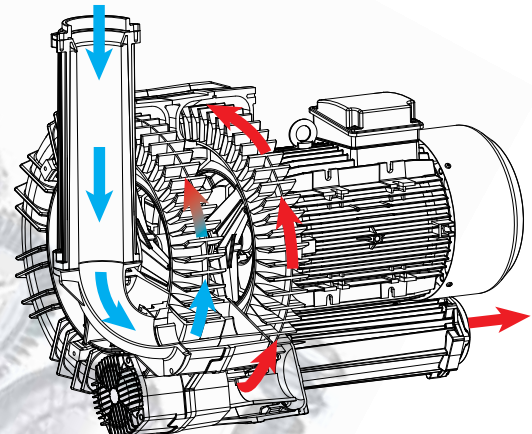

### Standard Design

The standard FPZ design is a direct drive configuration, with a dynamically balanced impeller fitted directly on the motor shaft. Fitted motors are 2-pole, 1 or 3 phase, rated for continuous service. Standard motors utilize class F insulation, are suitable for use with a variable speed drive (3 phase only), and are tropicalized for corrosion resistance. Single or two stage options are pictured above.

### GOR / GVR Design

"GOR / GVR" designs utilize a standard nema (or metric) electric motor that is directly coupled to the blower shaft. This direct coupled design allows the use of specialty motors that may be required to meet a variety of electrical requirements. For some models the vacuum / pressure capabilities can be increased with this GOR / GVR design (pictured right).

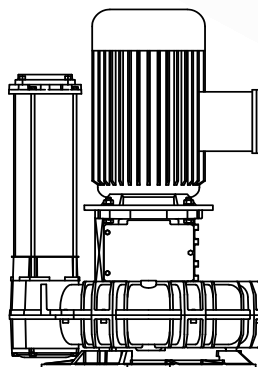

"GVR" Design

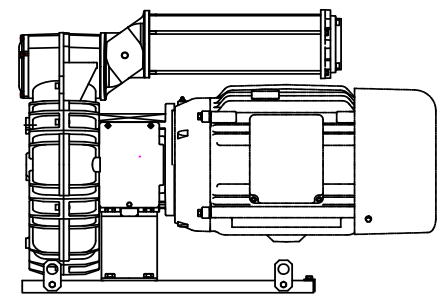

"GOR" Design



# Table of Contents

SS2501r1

Table of Contents					Page(s)	
General Pressure and Vacuum Performance Curves					4	5
<b>K Series "MOR" Blowers - Direct Drive</b>		Max CFM	Max Pressure (In H <sub>2</sub> O)	Max Vacuum (In Hg.)	Pressure	Vacuum
SCL K03-K06 MS	Single Stage Blowers	216	122	8.9	6-7	38-39
SCL K09-K10 MS	Single Stage Blowers	556	201	9.6	8-9	40-41
SCL K05-K06 TS	Single Stage Blowers	400	85	6.3	10-11	42-43
SCL K09-K10 TS	Single Stage Blowers	1093	110	8.1	12-13	44-45
SCL K09-10 MD	Two Stage Blowers	275	290	14.0	14-15	46-47
SCL K05-K06 TD	Two Stage Blowers	222	180	11.8	16-17	48-49
SCL K09-K10 TD	Two Stage Blowers	571	220	14.0	18-19	50-51
<b>O6 / R Series Performance Data</b>						
SCL O6	Single Stage Blower	39	52	3.5	20-21	52-53
SCL 15DH	Two Stage Blower	35	120.5	8.1	22-23	54-55
SCL R20-R40 MD	Two Stage Blowers	81	201	11.1	24-25	56-57
<b>K Series Direct Coupled - "GOR/GVR" configuration</b>						
SCL K03-K06 MS-GOR/GVR	Single Stage Blowers	216	140	9.6	26-27	58-59
SCL K09-K10 MS-GOR/GVR	Single Stage Blowers	556	200	10.3	28-29	60-61
SCL K05-K06 TS-GOR/GVR	Single Stage Blowers	400	130	7.8	30-31	62-63
SCL K09-K10 TS-GOR/GVR	Single Stage Blowers	1093	150	10.3	32-33	64-45
SCL K09-K10 MD-GOR/GVR	Two Stage Blowers	275	280	14.7	34-35	66-67
SCL K09-10 TD-GOR/GVR	Two Stage Blowers	571	240	13.2	36-37	68-69
<b>e Series Blowers - Direct Drive</b>		Max CFM	Max Pressure (In H <sub>2</sub> O)	Max Vacuum (In Hg.)	Pages	
SCL e07-MS	Single Stage Blower	307	160	10.3	70-71	
SCL e08-MS	Single Stage Blower	394	170	9.6	72-73	
SCL e11-MS	Single Stage Blower	639	150	11.0	74-75	
SCL e12-MS	Single Stage Blower	722	130	10.3	76-77	
SCL e07-TS	Single Stage Blower	582	100	8.1	78-79	
SCL e08-TS	Single Stage Blower	712	60	4.4	80-81	
SCL e11-TS	Single Stage Blower	1304	50	3.7	82-83	
SCL e12-TS	Single Stage Blower	1492	70	5.1	84-85	
SCL e07-MD	Two Stage Blower	147	260	13.2	86-87	
SCL e08-MD	Two Stage Blower	177	260	14.7	88-89	
SCL e11-MD	Two Stage Blower	270	280	13.2	90-91	
SCL e12-MD	Two Stage Blower	367	240	13.2	92-93	
SCL e07-TD	Two Stage Blower	304	220	12.5	94-95	
SCL e08-TD	Two Stage Blower	406	160	12.5	96-97	
SCL e11-TD	Two Stage Blower	665	130	9.6	98-99	
SCL e12-TD	Two Stage Blower	735	100	8.8	100-101	
<b>e Series "GOR" Blowers - Direct Coupled</b>						
SCL e07-e12 MS-GOR/GVR	Single Stage Blowers	722	170	10.3	102-103	
SCL e07-e12 TS-GOR/GVR	Single Stage Blowers	1404	140	10.3	104-105	
SCL e07-12 TD GOR	Two Stage Blowers	665	240	12.5	106-107	

### Disclaimer

The information contained in this catalog is based on information that we believe to be correct. It is the users responsibility to determine the suitability of the product for the application they are used in and the user assumes all risk and liability whatsoever in connection therewith.



## Table of Contents

552501

### Accessories

Installation Guide	General guide on how to install accessories.	108
VG / PG / CV / SS / IH	Gauges, Check Valves, Silencers, and Sound Enclosures	109
VRL6-9	Safety valve selection guide	110
VRL6-9	Safety Valves	111
CSL / CT	Filters for vacuum applications.	112
FS	Filters & dirty filter indicator for pressure applications	113
VK / PK	Flange Connectors for safety valves and flexible hoses	114
VS 6 / VS 8	Flow Converting Devices for diverting air stream	115
CA / CK	Filter Manifolds and 90 Degree Manifold for K series blowers	116
MF / TF / MP	Flexible Sleeves, Flanges, Sleeves	117
IH1 - IH5	Sound enclosures for models e/K03-06 -MS and R series.	118-119
25SC6 - 25SC10	Sound enclosures for models K05-6 TS/TD and SCL Ke07-12	120-123
25SB Base	Sound enclosure Base for models 25SC9 + 10 (MS/MD/TS)	124
AF	2 hp - 25 hp Motor Starters	125
CP	Control Panels and variable frequency drives	126-127

### Technical

Single Phase Motor information	128
Three Phase Motor Information	129
575 V Premium Efficiency Three Phase Motor Information	130
Altitude chart and conversion factors	131
Airflow Through an Orifice	132
FPZ Pneumatic Range	133

### How Blowers Work

Blowers have an impeller blade mounted inside a housing. As air passes the inlet port, impeller blades draw air in and accelerate the air outward and forward. As each impeller blade strikes it, the air moves faster and faster. At the base of the housing an air stripper diverts the air out of the housing reducing the speed and then increasing the pressure.

### Advantages of FPZ side channel blowers

- Compact execution
- Simple concept
- Reduced maintenance costs
- Modular design
- Pulsation and oil free air

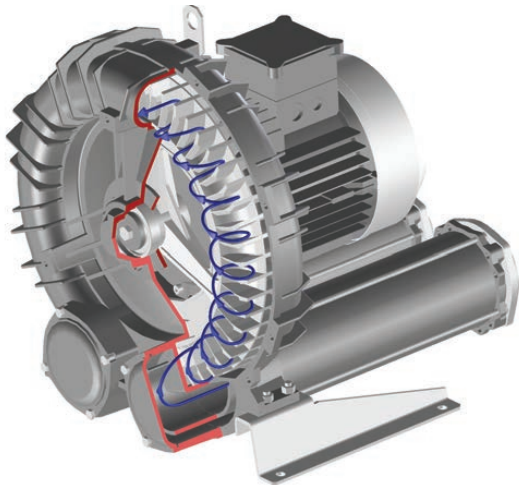

Thousands of FPZ blowers are working in a variety of applications: from commercial to industrial installations, in food processing to pharmaceuticals, from textiles to aerospace, in medical applications to environmental. Wherever efficiency and reliability are needed, FPZ responds with the appropriate product "solution"



# Pressure Performance Curves

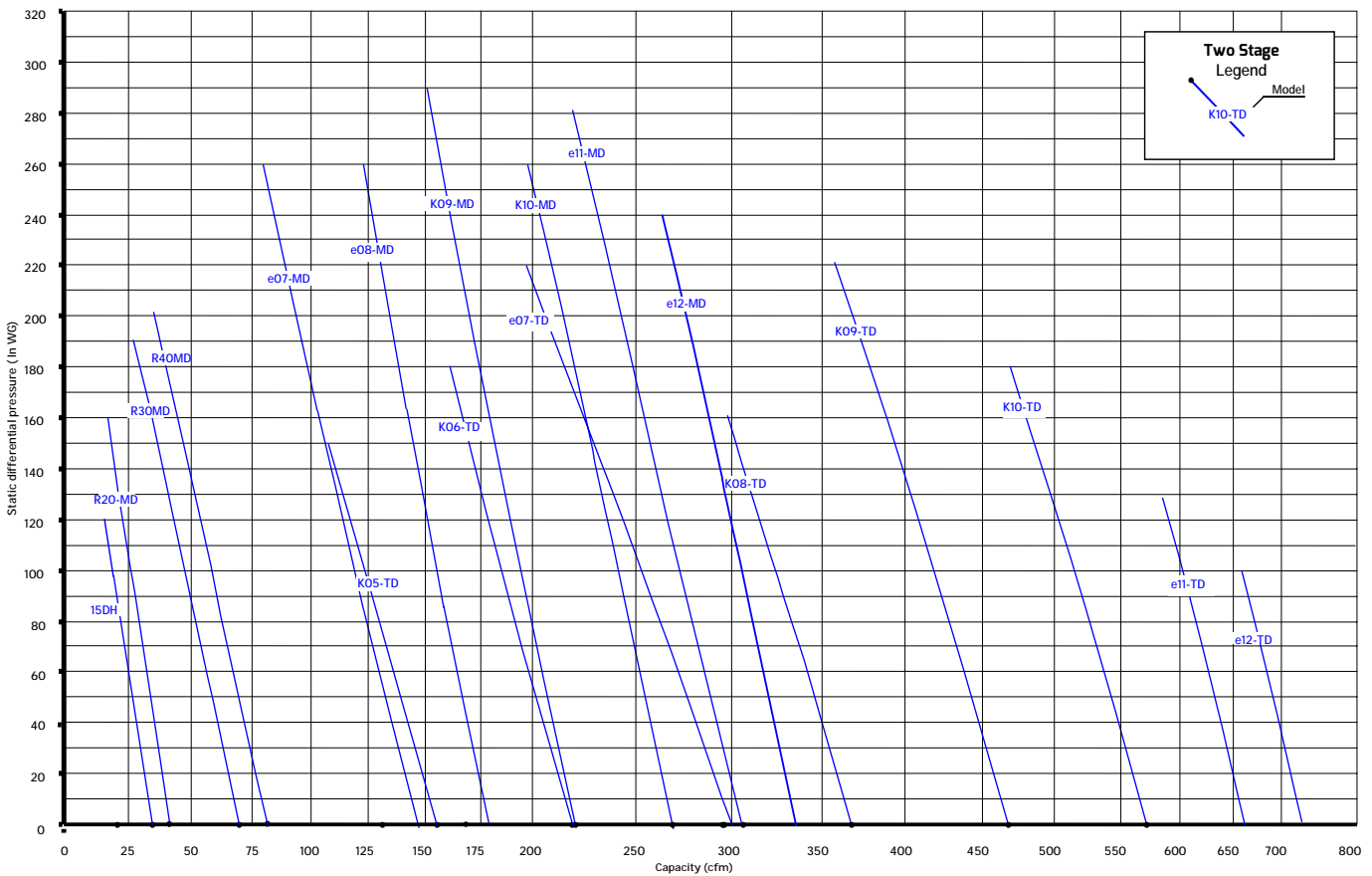
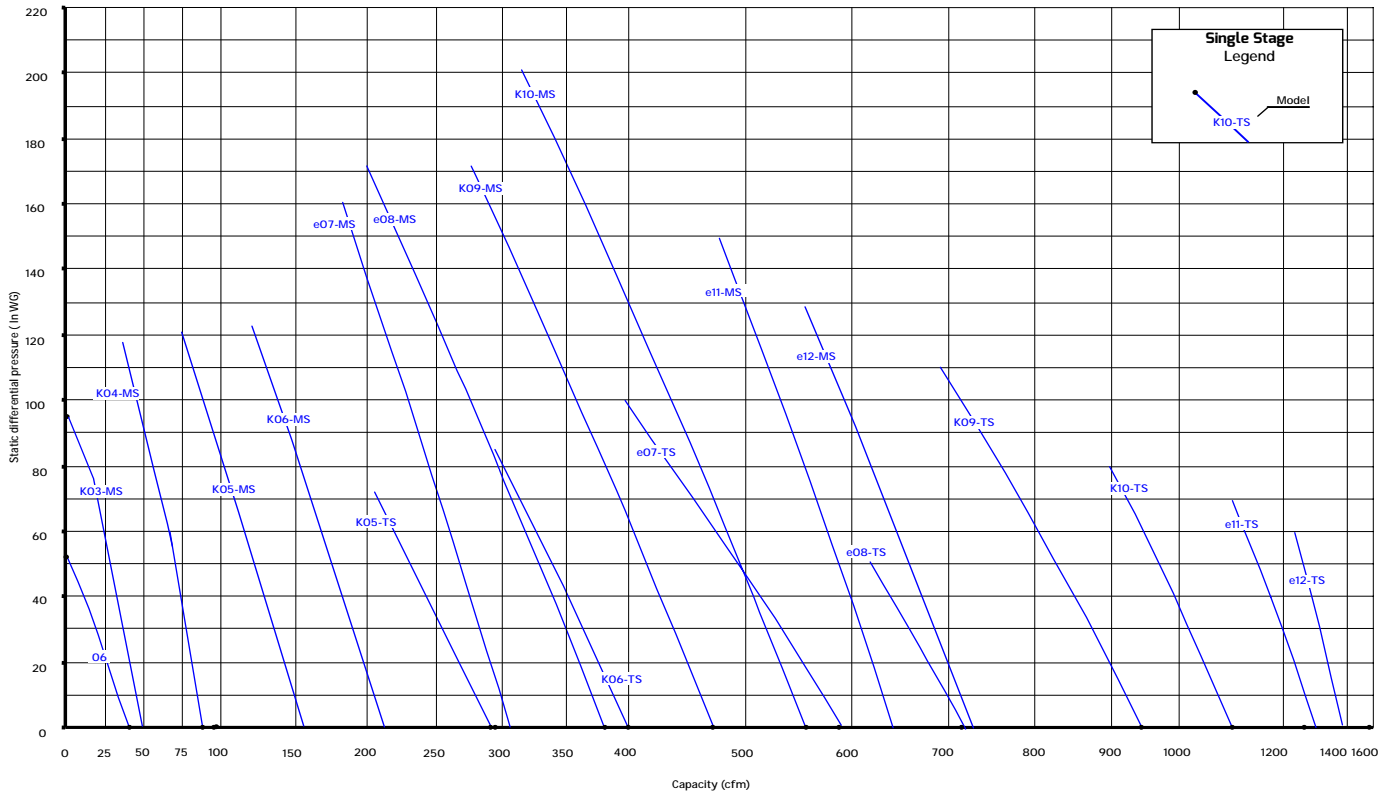

Curves refer to air at 68°F temperature and 29.92 in Hg atmospheric pressure (abs) measured at inlet port.  
Tolerance on given values ± 10% - data can change without prior notice.





# Vacuum Performance Curves

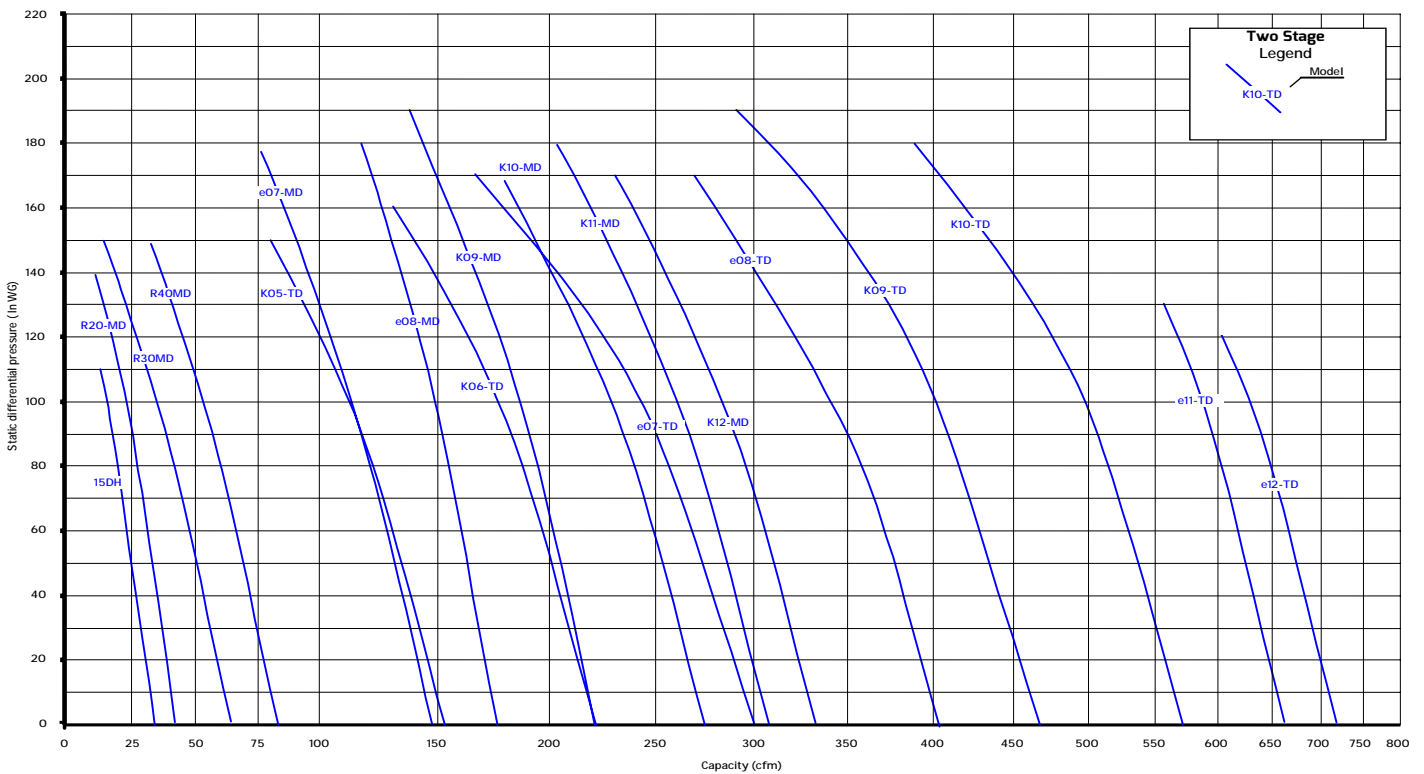
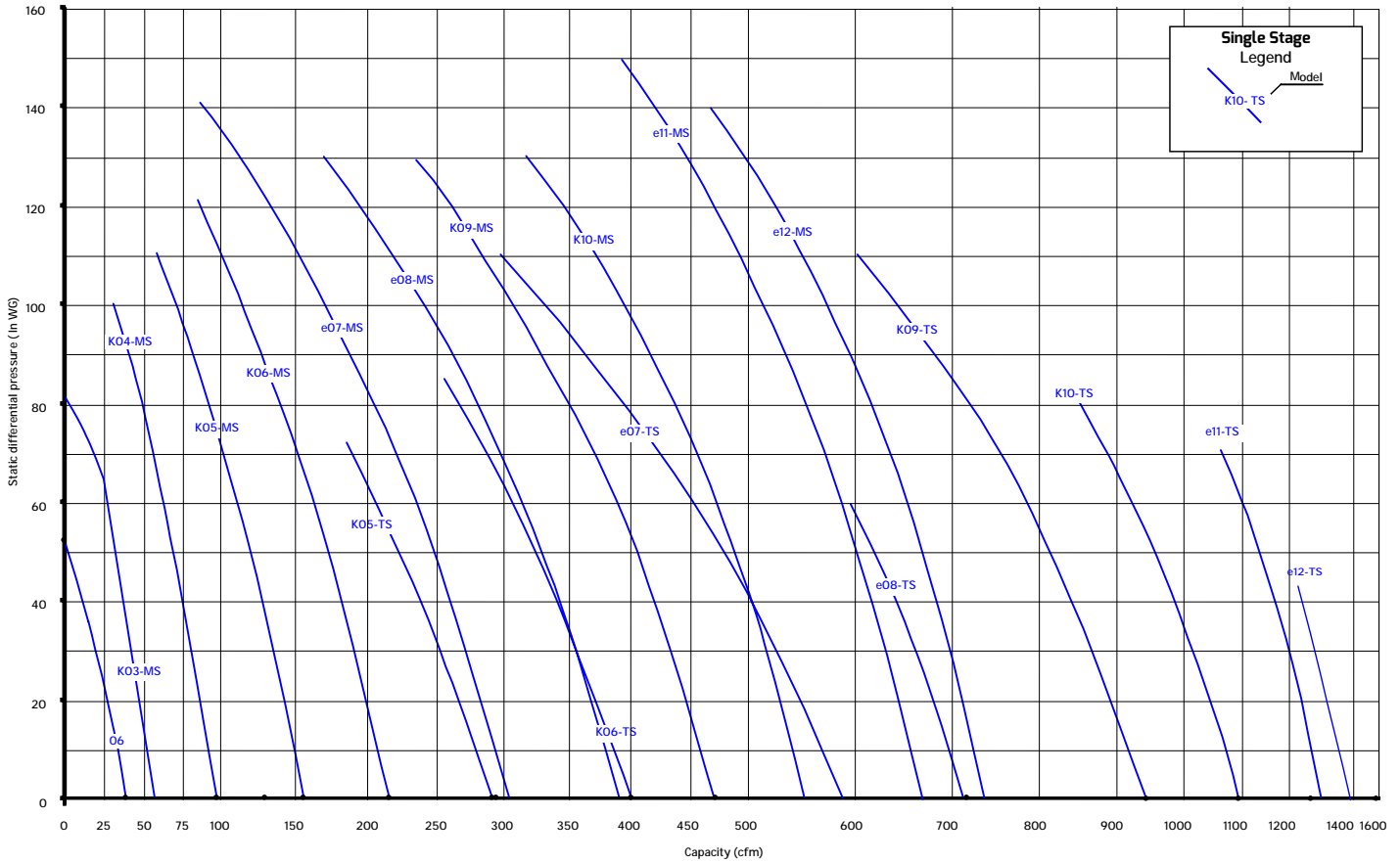

Curves refer to air at 68° F temperature, measured at inlet port and 29.92 In Hg atmospheric backpressure (abs).  
Tolerance on given values ± 10% - data can change without prior notice.



**TECHNICAL CHARACTERISTICS**

- Aluminium alloy construction
- Smooth operation
- High efficiency impeller
- Maintenance free
- Mountable in any position
- Recognized TEFC - cURus motor

**OPTIONS**

- Special voltages (IEC 38)
- Surface treatments

**ACCESSORIES**

- Inlet and/or inline filters
- Additional inlet/outlet silencers
- Safety valves
- Flow converting device
- Optional connectors

Dimensions in inches.  
Dimension for reference only.

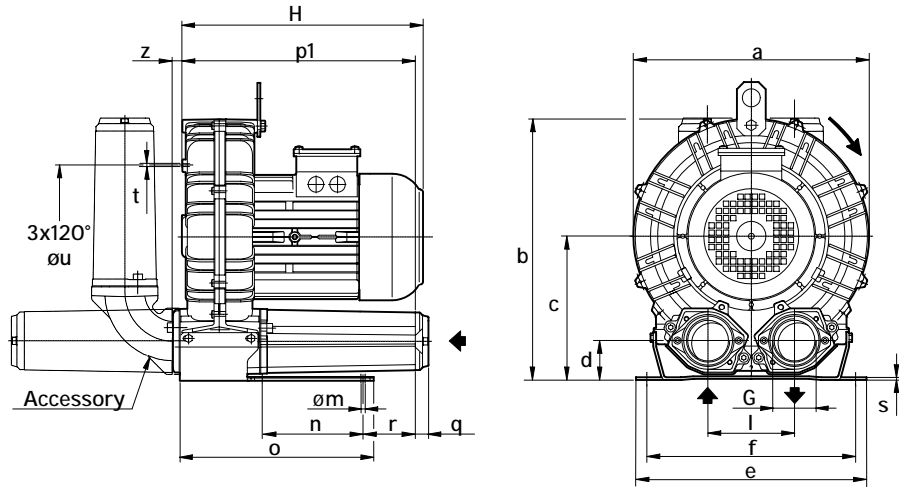

Model	a	b	c	d	e	f	G	l	m	n	o	p1	q	r	s	t	u	z
K03-MS	9.49	10.55	5.79	1.69	9.06	8.07	1 1/4 NPT	3.39	0.39	3.27	5.59	8.07	0.71	2.95	0.16	M6	5.51	0.47
K04-MS	11.22	12.40	6.77	1.93	10.04	8.86	1 1/2 NPT	4.02	0.47	3.74	6.73	8.74	0.71	2.76	0.16	M6	6.89	0.71
K05-MS	12.87	14.37	7.87	2.13	12.80	10.24	2" NPT	4.72	0.59	4.53	10.43	12.60	0.71	3.86	0.16	M8	7.87	0.75
K06-MS	14.80	15.47	8.07	2.13	12.80	11.42	2" NPT	4.92	0.59	5.51	10.71	13.15	0.71	3.35	0.16	M8	9.45	0.75

Model	Maximum flow Scfm		Installed power Hp		Maximum differential pressure Δp (In WG)		Noise level Lp dB (A) <sup>(1)</sup>		Overall dimensions H Inches	Weight Lbs
	60 Hz 3500 rpm	50 Hz 2900 rpm	60 Hz 3500 rpm	50 Hz 2900 rpm	60 Hz 3500 rpm	50 Hz 2900 rpm	60 Hz 3500 rpm	50 Hz 2900 rpm		
K03-MS	52	43	3/4	3/4	64	60	62.0	60.0	10.43	24.3
			1	1	95	72	62.3	60.3	12.0	32.0
K04-MS	98	81	1 1/2	1 1/2	58	80	64.8	62.8	11.65	40.3
			2	2	85	100	65.0	63.0	14.20	56.8
			3	-	120	-	65.2	-	14.20	58.4
K05-MS	156	129	2	2	52	70	70.5	68.5	13.20	56.7
			3	3	80	110	70.8	68.8	13.20	60.6
			4	4	120	120	71.1	69.1	14.40	77.2
K06-MS	216	179	3	3	40	65	73.0	71.0	13.80	69.0
			4	4	64	95	73.3	71.3	14.17	82.5
			5 1/2	5 1/2	110	130	73.6	71.6	15.5	85.3
			6 1/5	-	122	-	73.9	-	16.3	95.5

(1) Noise measured at 1 m distance with inlet and outlet ports piped, in accordance to ISO 3744.

- For proper use, the blower should be equipped with inlet filter and safety valve; other accessories available on request.
- Ambient temperature from +5° to +104°F.
- Specifications subject to change without notice.



SCL K03 / K04 / K05 / K06  
MS SERIES  
SN 1874-15B 2/2

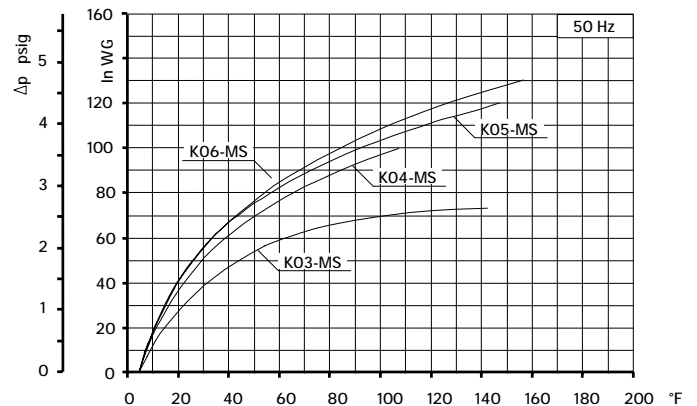
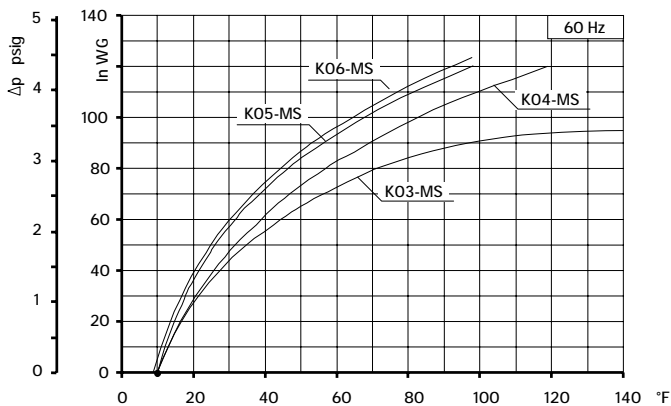
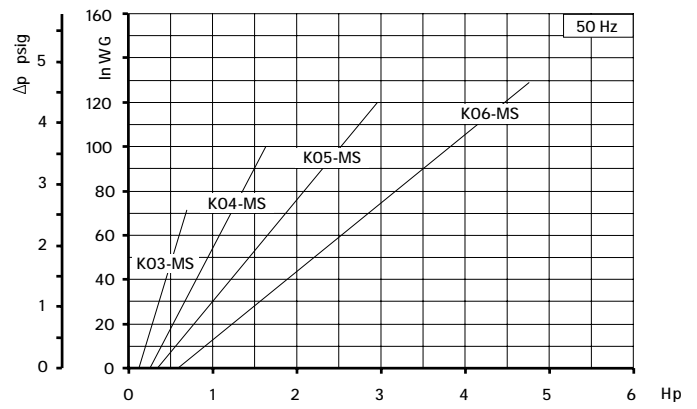
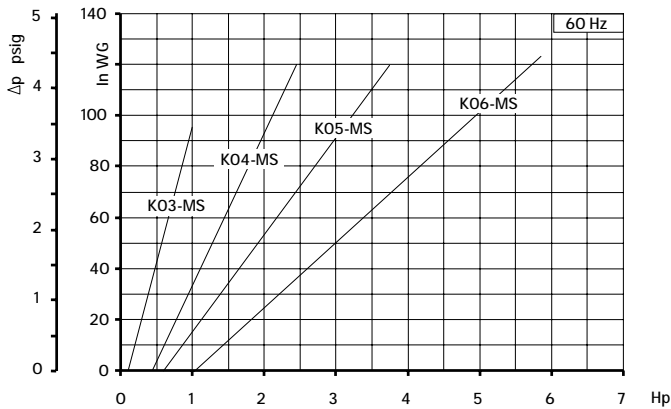
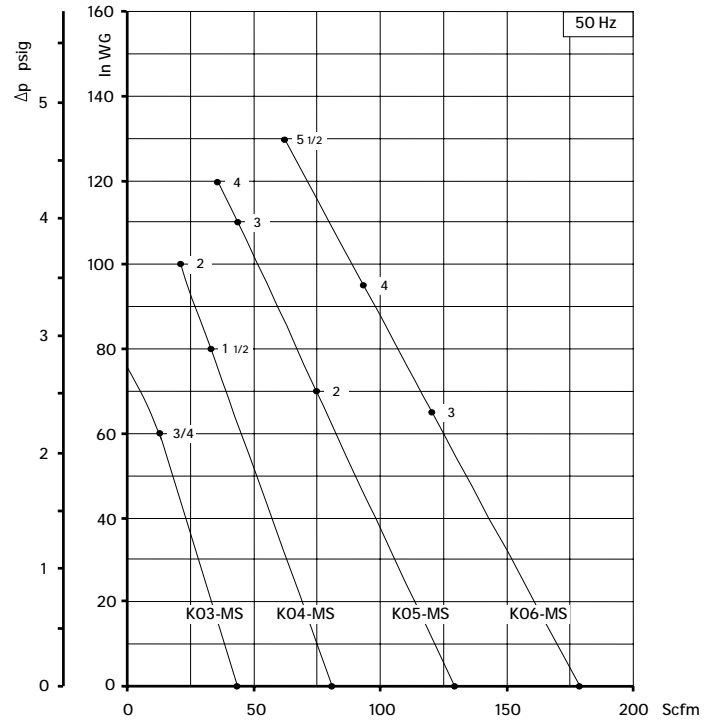
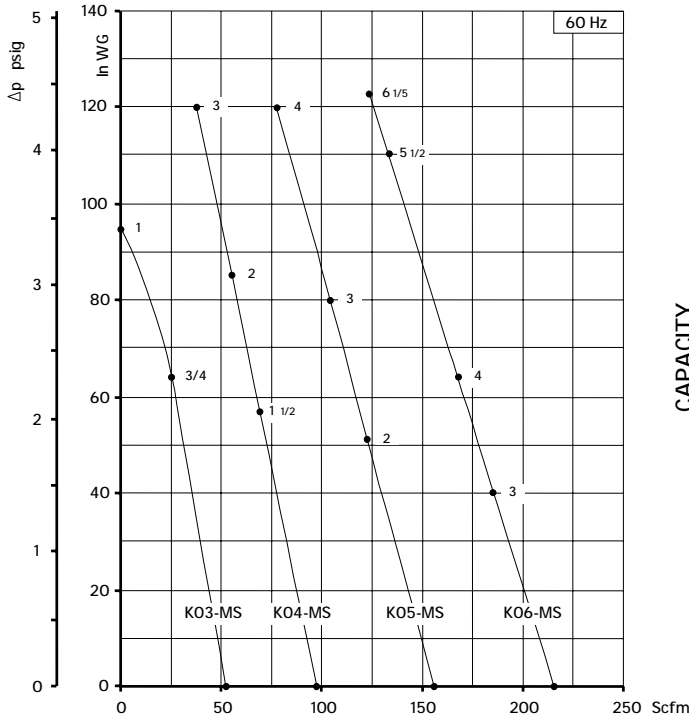

Curves refer to air at 68°F temperature and 29.92 In Hg atmospheric pressure (abs) measured at inlet port.  
Values for flow, power consumption and temperature rise: +/- 10% tolerance.  
Data subject to change without notice.



SCL K09 / K10  
MS SERIES

SN1805-20 1/2

TECHNICAL CHARACTERISTICS

- Aluminium alloy construction
- Smooth operation
- High efficiency impeller
- Maintenance free
- Mountable in any position
- Recognized TEFC - cURus motor

OPTIONS

- Special voltages (IEC 38)
- Surface treatments

ACCESSORIES

- Inlet and/or inline filters
- Additional inlet/outlet silencers
- Safety valves
- Flow converting device
- Optional connectors

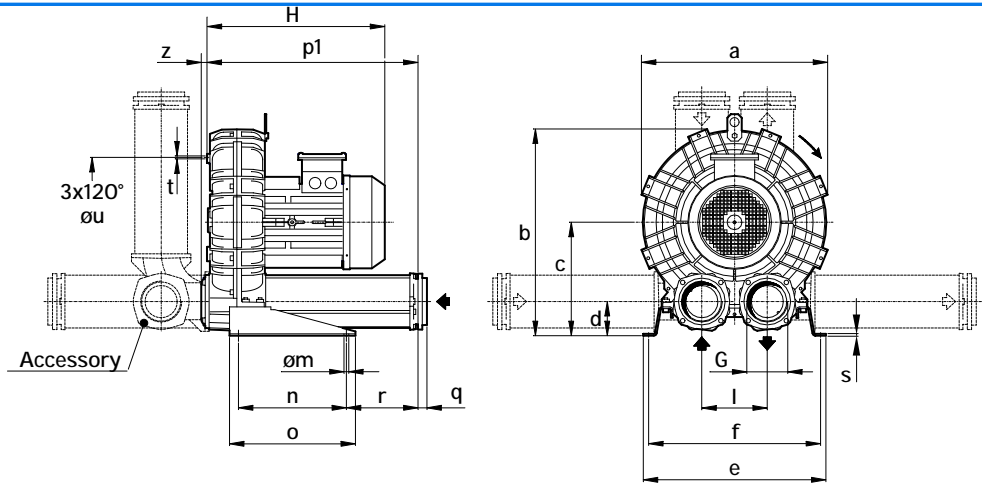

Dimensions in inches.  
Dimension for reference only.

Model	a	b	c	d	e	f	G	l	m	n	o	p1	q	r	s	t	u	z
K09-MS	19.37	22.09	12.40	3.78	20.00	18.82	4" NPT	7.17	0.51	11.81	13.78	23.07	0.98	7.83	0.20	M8	14.17	0.63
K10-MS	20.31	22.56	12.40	3.78	20.00	18.82	4" NPT	7.17	0.51	11.81	13.78	23.07	0.98	7.83	0.20	M8	14.17	0.63

Model	Maximum flow Scfm		Installed power Hp		Maximum differential pressure Δp (In WG)		Noise level Lp dB (A) <sup>(1)</sup>		Overall dimensions H Inches	Weight Lbs
	60 Hz	50 Hz	60 Hz	50 Hz	60 Hz	50 Hz	60 Hz	50 Hz		
	3500 rpm	2900 rpm	3500 rpm	2900 rpm	3500 rpm	2900 rpm	3500 rpm	2900 rpm		
K09-MS	471	390	7 ½	7 ½	50	80	80.2	78.2	18.8	186.3
			10	10	80	120	80.5	78.5	19.5	199.0
			15	15	141	171	81.0	79.0	19.6	212.0
			20	20	171	-	81.3	79.3	22.0	245.0
K10-MS	556	460	7 ½	7 ½	30	60	80.1	78.1	18.8	189.6
			10	10	50	90	80.5	78.5	19.5	202.0
			15	15	111	141	81.0	79.0	19.6	215.0
			20	20	161	171	81.4	79.4	22.0	248.0
			25	25	201	-	81.6	79.6	24.0	322.0

(1) Noise measured at 1 m distance with inlet and outlet ports piped, in accordance to ISO 3744.

- For proper use, the blower should be equipped with inlet filter and safety valve; other accessories available on request.
- Ambient temperature from +5° to +104°F.
- Specifications subject to change without notice.

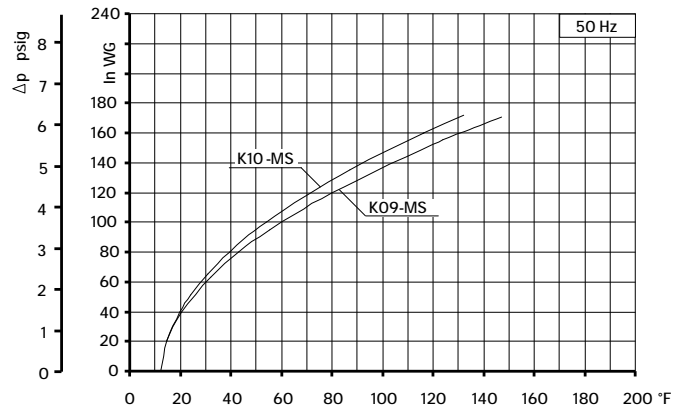
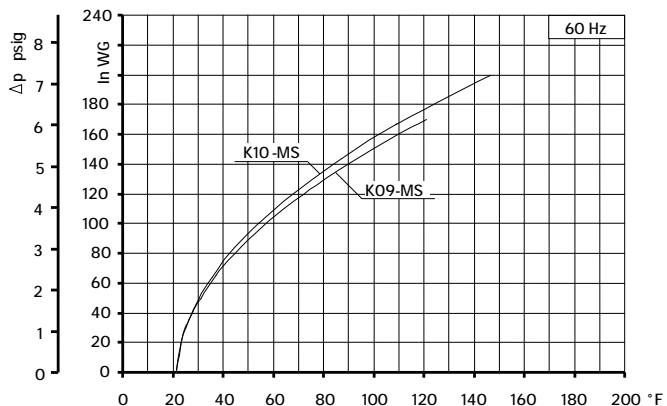
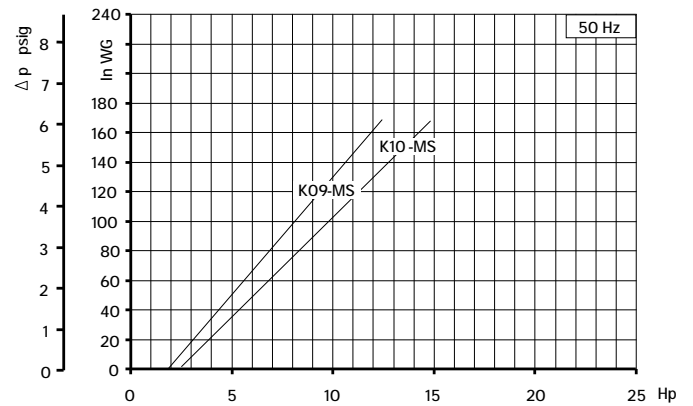
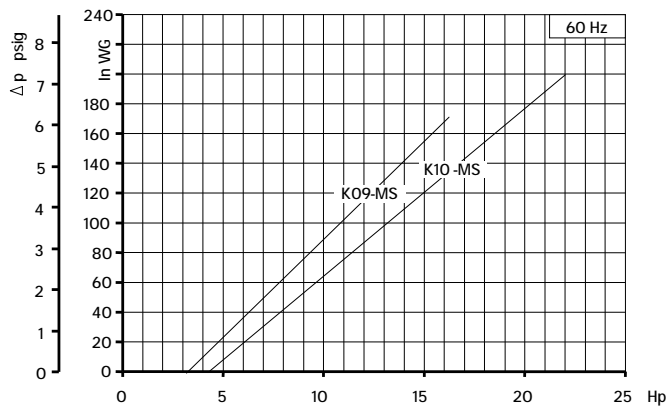
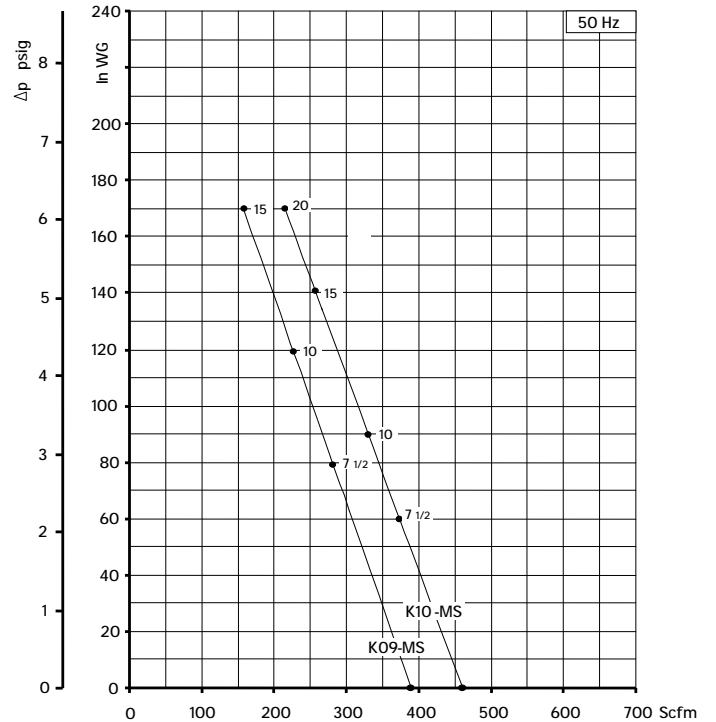
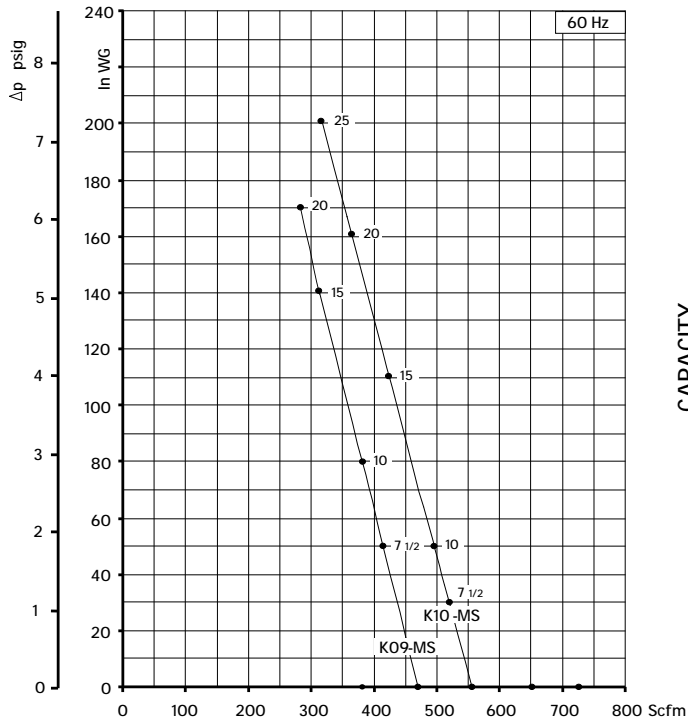

Curves refer to air at 68°F temperature and 29.92 In Hg atmospheric pressure (abs) measured at inlet port.  
 Values for flow, power consumption and temperature rise: +/- 10% tolerance.  
 Data subject to change without notice.





SCL K05 / K06  
TS SERIES

SN 1921-10B 1/2

TECHNICAL CHARACTERISTICS

- Aluminium alloy construction
- Smooth operation
- High efficiency impeller
- Maintenance free
- Mountable in any position
- Recognized TEFC - cURus motor 3x120°øu

OPTIONS

- Special voltages (IEC 38)
- Surface treatments

ACCESSORIES

- Inlet and/or inline filters
- Additional inlet/outlet silencers
- Safety valves
- Flow converting device
- Optional connectors

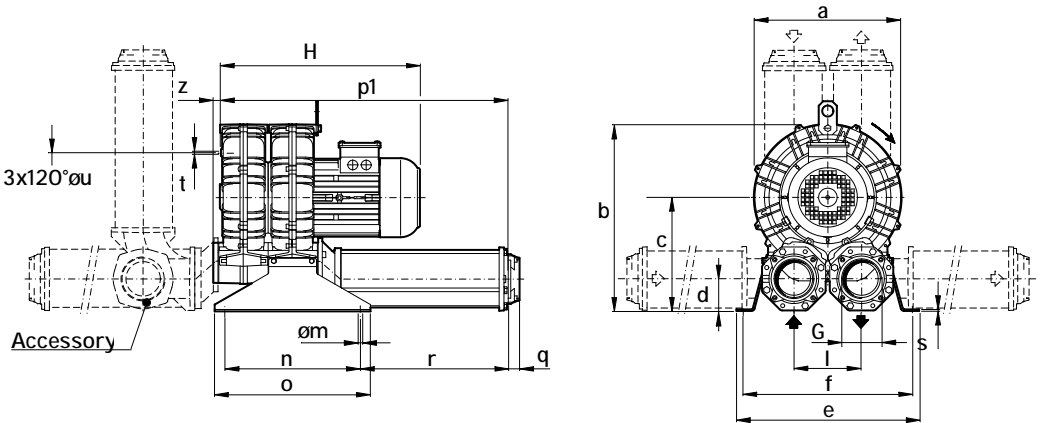

Dimensions in inches.  
Dimension for reference only.

Model	a	b	c	d	e	f	G	l	m	n	o	p1	q	r	s	t	u	z
K05-TS	12.87	16.61	10.16	3.03	15.91	14.72	3" NPT	5.91	0.51	11.81	13.58	24.96	0.98	12.91	0.16	M8	7.87	0.75
K06-TS	14.80	17.72	10.31	2.95	15.91	14.72	3" NPT	6.10	0.51	11.81	13.58	26.06	0.98	13.19	0.16	M8	9.45	0.75

Model	Maximum flow Scfm		Installed power Hp		Maximum differential pressure Δp (In WG)		Noise level Lp dB (A) <sup>(1)</sup>		Overall dimensions H Inches	Weight Lbs
	60 Hz 3500 rpm	50 Hz 2900 rpm	60 Hz 3500 rpm	50 Hz 2900 rpm	60 Hz 3500 rpm	50 Hz 2900 rpm	60 Hz 3500 rpm	50 Hz 2900 rpm		
K05-TS	290	241	5 ½	5 ½	72	100	75.5	73.5	19.5	109.0
K06-TS	400	331	10	10	85	111	77.8	75.8	24.5	181.0

(1) Noise measured at 1 m distance with inlet and outlet ports piped, in accordance to ISO 3744.

- For proper use, the blower should be equipped with inlet filter and safety valve; other accessories available on request.
- Ambient temperature from +5° to +104°F.
- Specifications subject to change without notice.



SCL K05 / K06  
TS SERIES

SN 1921-10B 2/2

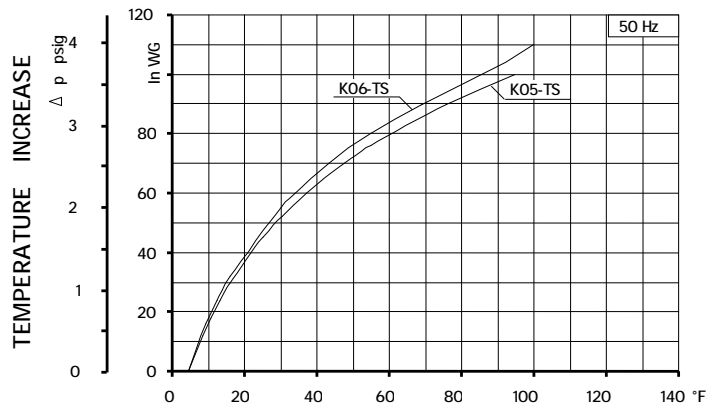
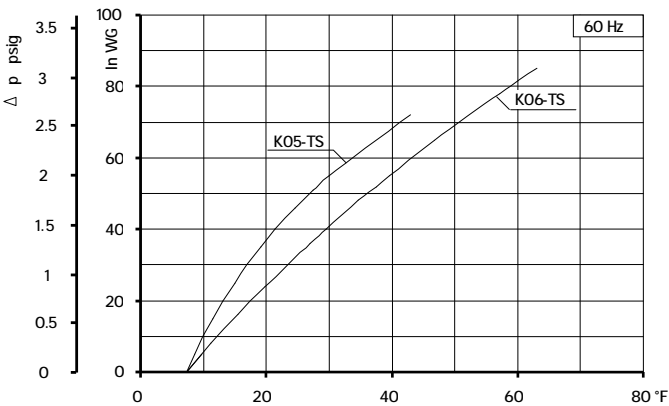
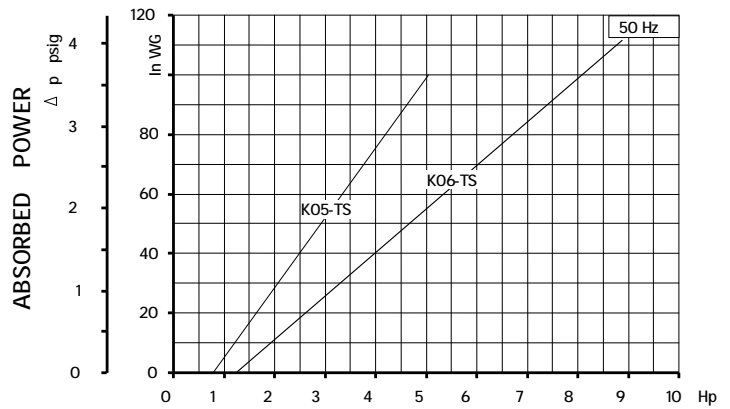
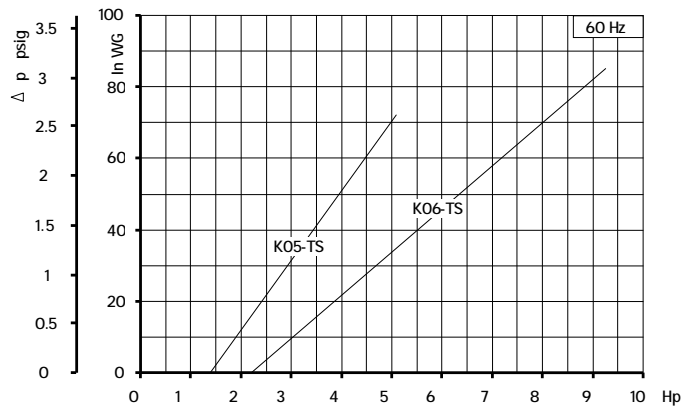
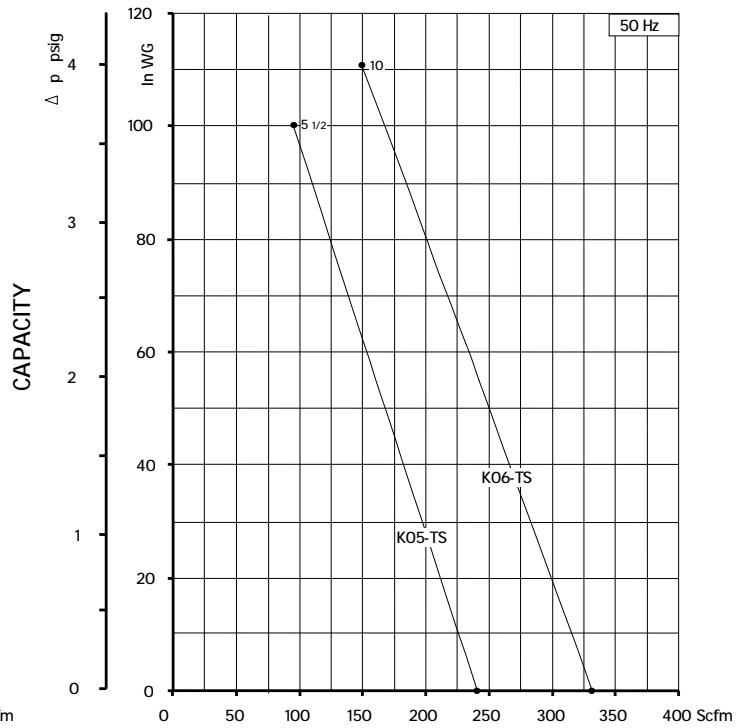
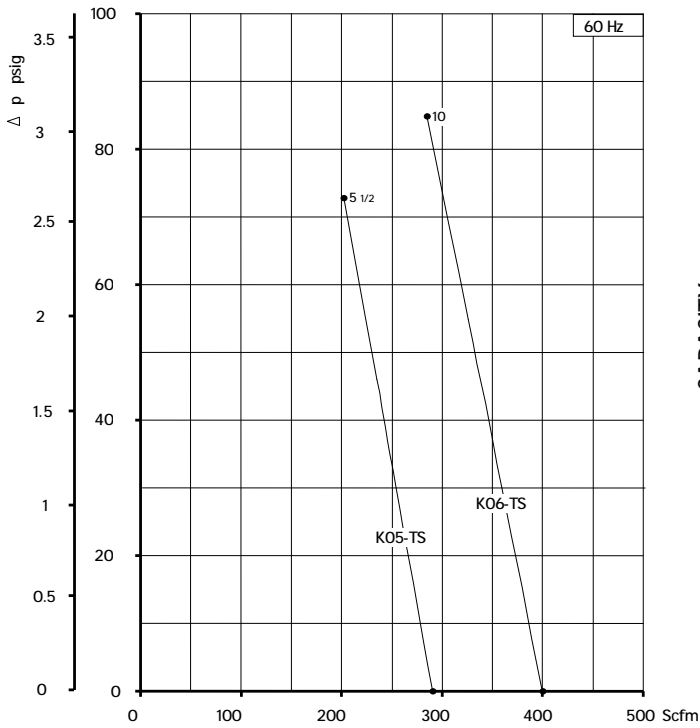

Curves refer to air at 68°F temperature and 29.92 In Hg atmospheric pressure (abs) measured at inlet port.  
Values for flow, power consumption and temperature rise: +/-10% tolerance.  
Data subject to change without notice.



**TECHNICAL CHARACTERISTICS**

- Aluminium alloy construction
- Smooth operation
- High efficiency impeller
- Maintenance free
- Mountable in any position
- Recognized TEFC - cURus motor
- G 1/8" female thread on both suction and discharge silencer port flanges

**OPTIONS**

- Special voltages (IEC 38)
- Surface treatments

**ACCESSORIES**

- Inlet and/or inline filters
- Additional inlet/outlet silencers
- Safety valves
- Flow converting device
- Optional connectors

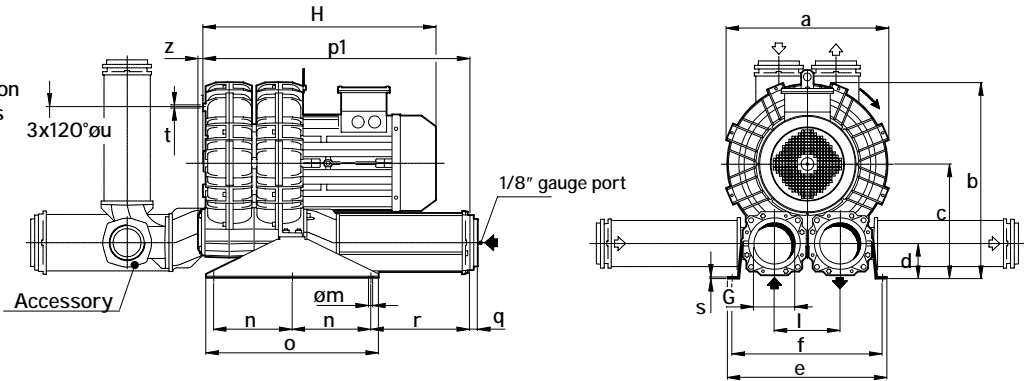

Dimensions in inches.  
Dimension for reference only.

Model	a	b	c	d	e	f	G	l	m	n	o	p1	q	r	s	t	u	z
K09-TS	19.37	24.02	14.37	4.41	20.08	18.82	5" NPT	8.27	0.51	9.84	21.65	33.46	1.38	12.40	0.20	M8	14.17	0.63
K10-TS	20.31	24.53	14.37	4.41	20.08	18.82	5" NPT	8.27	0.51	9.84	21.65	33.46	1.38	12.40	0.20	M8	14.17	0.63

Model	Maximum flow Scfm		Installed power Hp		Maximum differential pressure Δp (In WG)		Noise level Lp dB (A) (1)		Overall dimensions H Inches	Weight Lbs
	60 Hz 3500 rpm	50 Hz 2900 rpm	60 Hz 3500 rpm	50 Hz 2900 rpm	60 Hz 3500 rpm	50 Hz 2900 rpm	60 Hz 3500 rpm	50 Hz 2900 rpm		
K09-TS	941	780	20	20	80	100	85.0	83.0	31.0	422.0
			25	25	110	141	87.0	85.0	31.0	432.0
K10-TS	1093	906	20	20	50	80	88.1	86.1	31.0	429.0
			25	25	80	100	88.4	86.4	31.0	439.0

(1) Noise measured at 1 m distance with inlet and outlet ports piped, in accordance to ISO 3744.

- For proper use, the blower should be equipped with inlet filter and safety valve; other accessories available on request.
- Ambient temperature from +5° to +104°F.
- Specifications subject to change without notice.

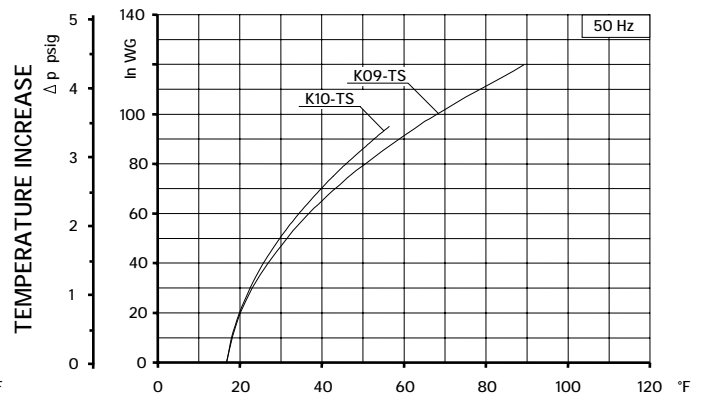
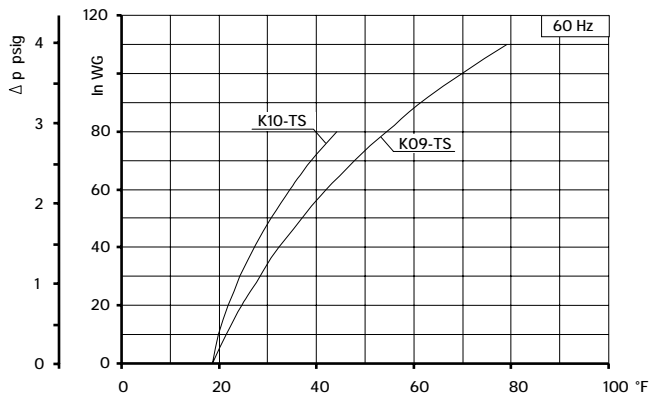
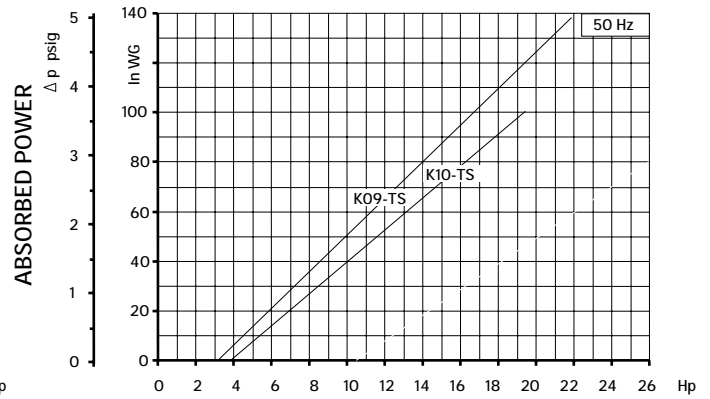
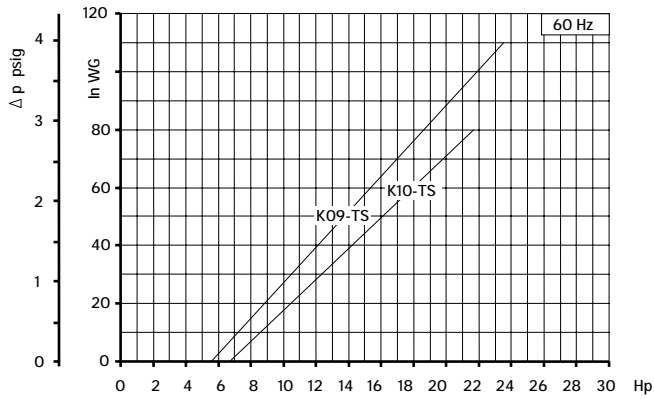
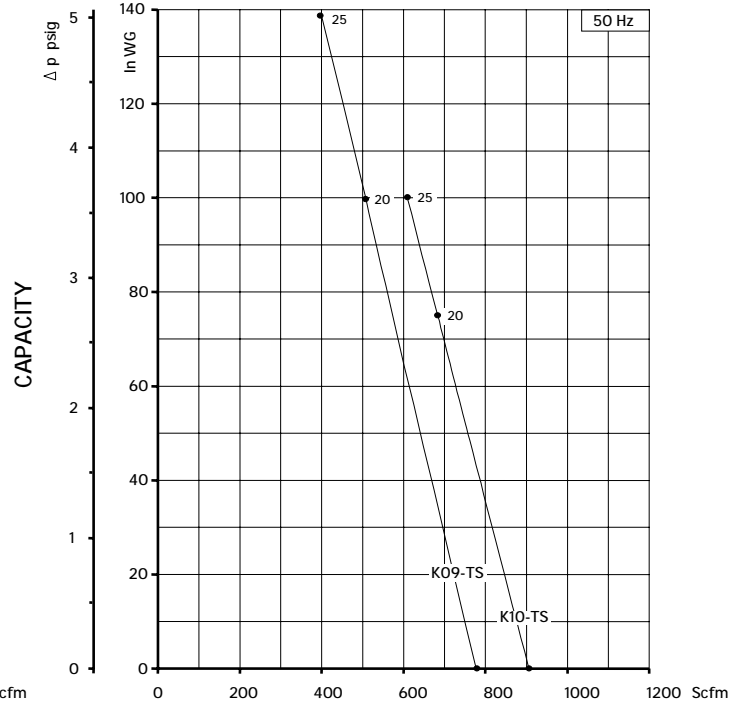
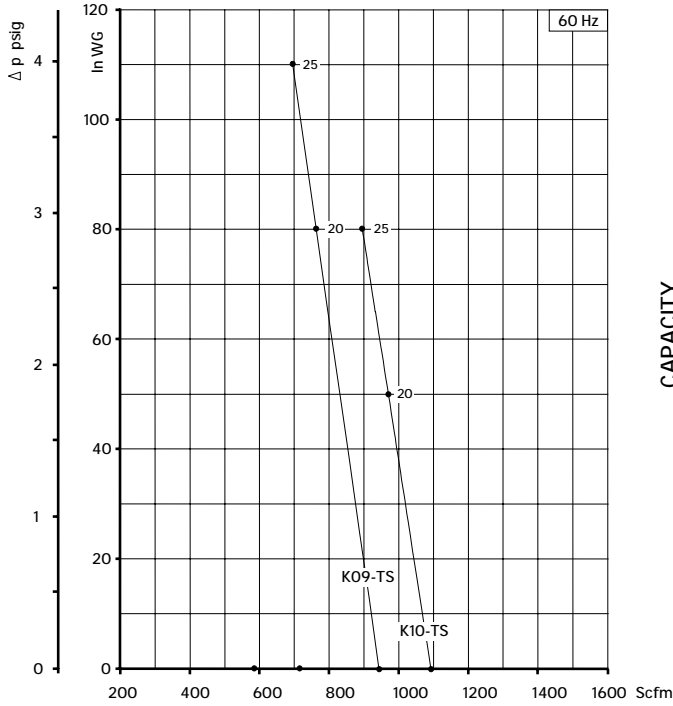

Curves refer to air at 68°F temperature and 29.92 In Hg atmospheric pressure (abs) measured at inlet port.  
Values for flow, power consumption and temperature rise: +/-10% tolerance.  
Data subject to change without notice.



**TECHNICAL CHARACTERISTICS**

- Aluminium alloy construction
- Smooth operation
- High efficiency impeller
- Maintenance free
- Mountable in any position
- Recognized TEFC - cURus motor

**OPTIONS**

- Special voltages (IEC 38)
- Surface treatments

**ACCESSORIES**

- Inlet and/or inline filters
- Additional inlet/outlet silencers
- Safety valves
- Flow converting device
- Optional connectors

Dimensions in inches.  
Dimension for reference only.

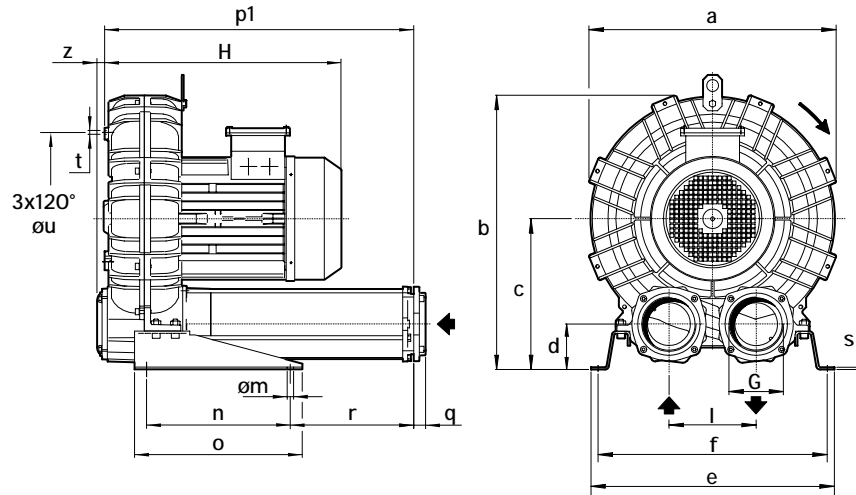

Model	a	b	c	d	e	f	G	l	m	n	o	p1	q	r	s	t	u	z
K09-MD	19.37	22.09	12.40	3.78	20.00	18.82	4" NPT	7.17	0.51	11.81	13.78	25.35	0.98	10.12	0.20	M8	14.17	0.63
K10-MD	20.31	22.56	12.40	3.78	20.00	18.82	4" NPT	7.17	0.51	11.81	13.78	25.35	0.98	10.12	0.20	M8	14.17	0.63

Model	Maximum flow Scfm		Installed power Hp		Maximum differential pressure Δp (In WG)		Noise level Lp dB (A) (1)		Overall dimensions H Inches	Weight Lbs
	60 Hz 3500 rpm	50 Hz 2900 rpm	60 Hz 3500 rpm	50 Hz 2900 rpm	60 Hz 3500 rpm	50 Hz 2900 rpm	60 Hz 3500 rpm	50 Hz 2900 rpm		
K09-MD	221	183	10	10	190	250	79.5	77.5	19.50	210
			15	15	290	-	80.5	78.5	19.50	223
K10-MD	275	228	10	10	130	200	80.3	78.3	19.50	214
			15	15	240	260	81.4	79.4	19.50	228
			20	20	260	-	81.7	79.7	22.00	264

(1) Noise measured at 1 m distance with inlet and outlet ports piped, in accordance to ISO 3744.

- For proper use, the blower should be equipped with inlet filter and safety valve; other accessories available on request.
- Ambient temperature from +5° to +104°F.
- Specifications subject to change without notice.



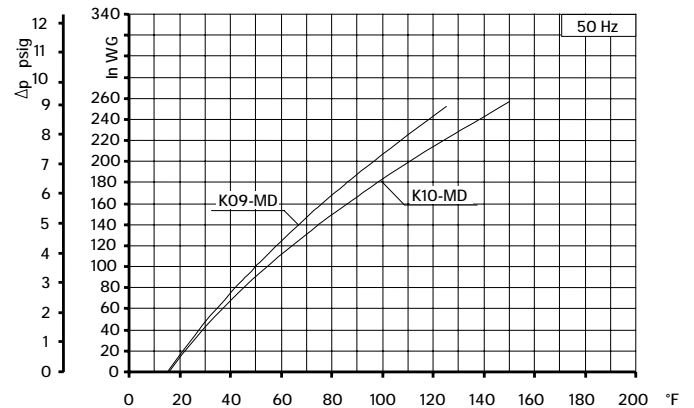
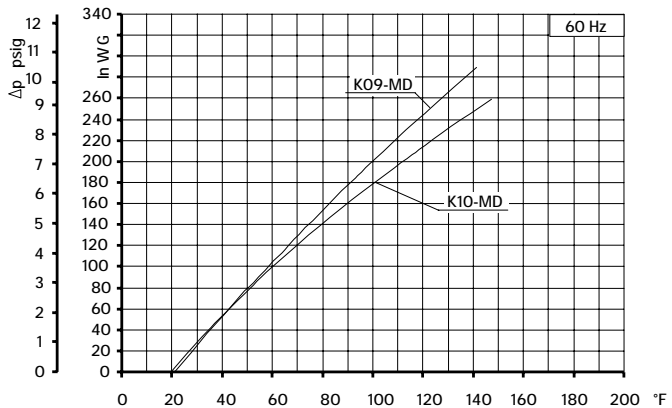
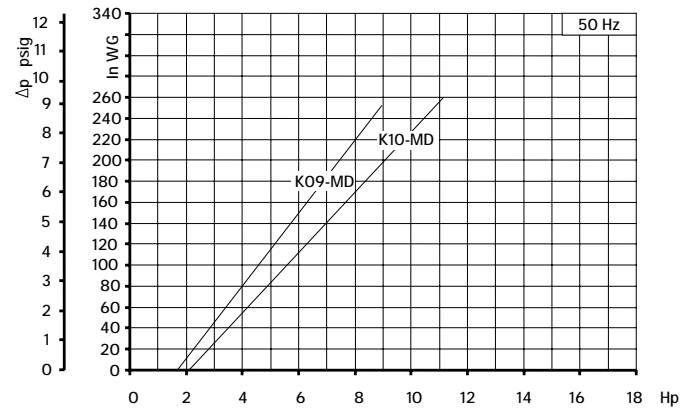
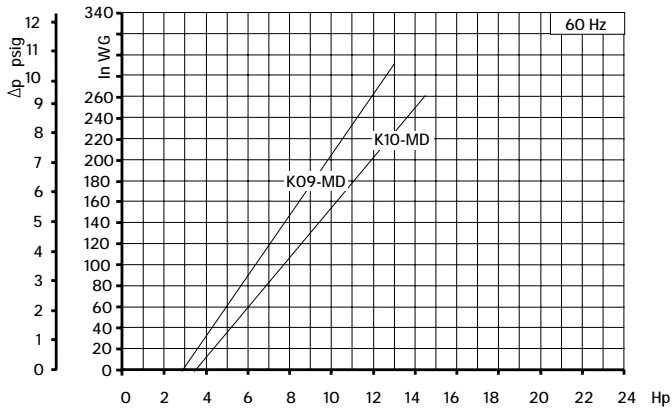
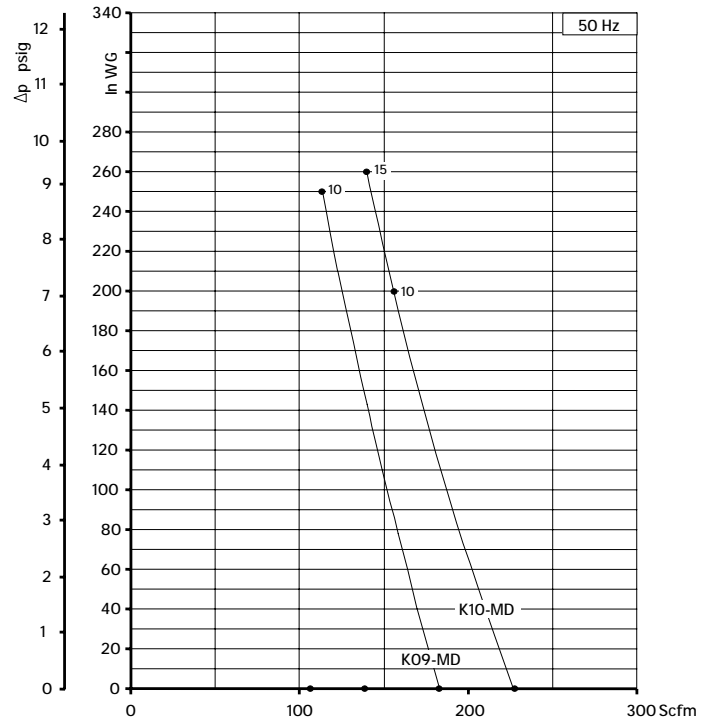
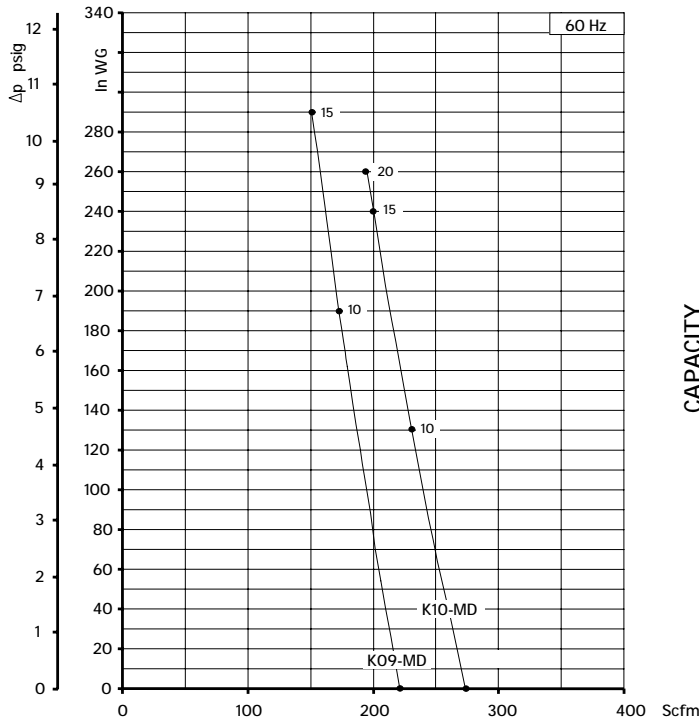

Curves refer to air at 68°F temperature and 29.92 In Hg atmospheric pressure (abs) measured at inlet port.  
 Values for flow, power consumption and temperature rise: +/-10% tolerance.  
 Data subject to change without notice.



**TECHNICAL CHARACTERISTICS**

- Aluminium alloy construction
- Smooth operation
- High efficiency impeller
- Maintenance free
- Mountable in any position
- Recognized TEFC - cURus motor

**OPTIONS**

- Special voltages (IEC 38)
- Surface treatments

**ACCESSORIES**

- Inlet and/or inline filters
- Additional inlet/outlet silencers
- Safety valves
- Flow converting device
- Optional connectors

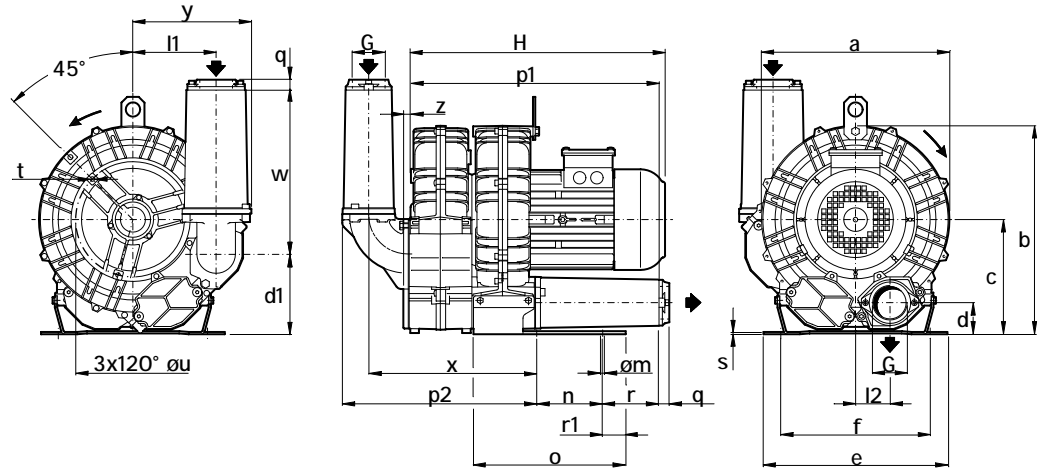

Dimensions in inches.  
Dimension for reference only.

Model	a	b	c	d	d1	e	f	G	l1	l2	m	n	o	p1	p2	q	r	r1	s	t	u	w	x	y	z
K05-TD	12.87	14.37	7.87	2.13	5.51	12.60	10.24	2" NPT	5.71	2.36	0.59	4.53	10.43	16.85	13.39	0.71	3.86	1.57	0.16	M8	7.87	11.26	11.54	8.11	0.75
K06-TD	14.80	16.54	9.13	2.32	6.69	12.80	11.42	2" NPT	5.94	2.87	0.59	5.51	10.43	19.92	13.94	0.71	5.35	0.75	0.16	M8	9.45	11.26	12.13	8.27	0.75

Model	Maximum flow Scfm		Installed power Hp		Maximum differential pressure Δp (In WG)		Noise level Lp dB (A) <sup>(1)</sup>		Overall dimensions H	Weight
	60 Hz	50 Hz	60 Hz	50 Hz	60 Hz	50 Hz	60 Hz	50 Hz		
	3500 rpm	2900 rpm	3500 rpm	2900 rpm	3500 rpm	2900 rpm	3500 rpm	2900 rpm	Inches	Lbs
K05-TD	153	127	5 ½	5 ½	150	190	76.0	74.0	19.5	101.0
K06-TD	222	184	10	10	180	220	77.0	75.0	24.5	174.5

(1) Noise measured at 1 m distance with inlet and outlet ports piped, in accordance to ISO 3744.

- For proper use, the blower should be equipped with inlet filter and safety valve; other accessories available on request.
- Ambient temperature from +5° to +104°F.
- Specifications subject to change without notice.



SCL K05 / K06  
TD SERIES

SN 1931-9B 2/2

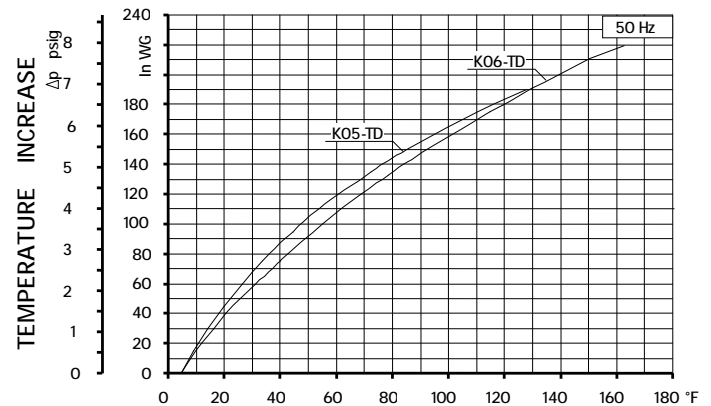
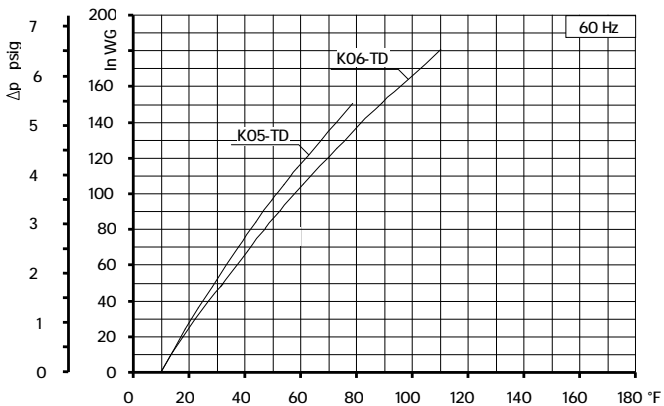
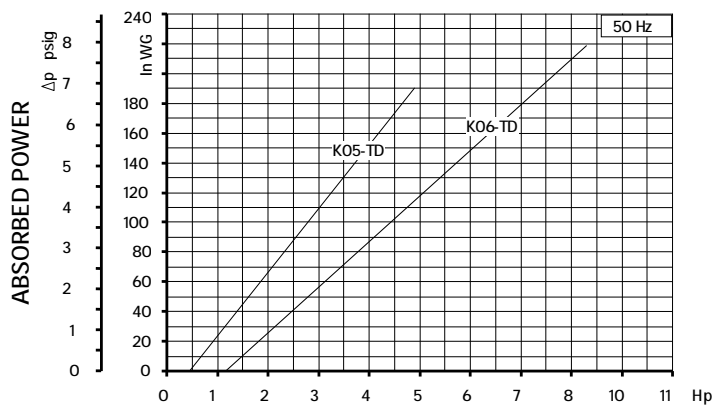
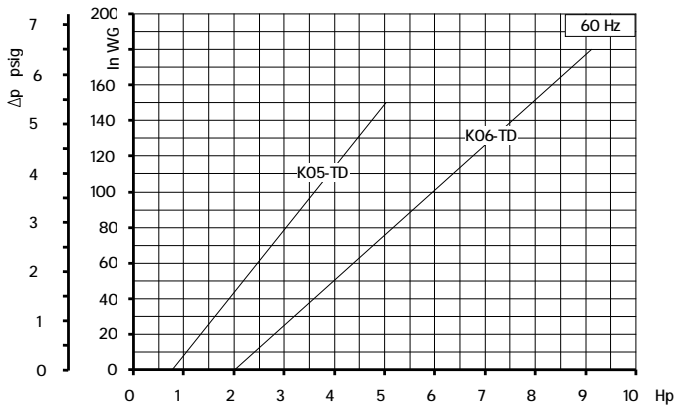
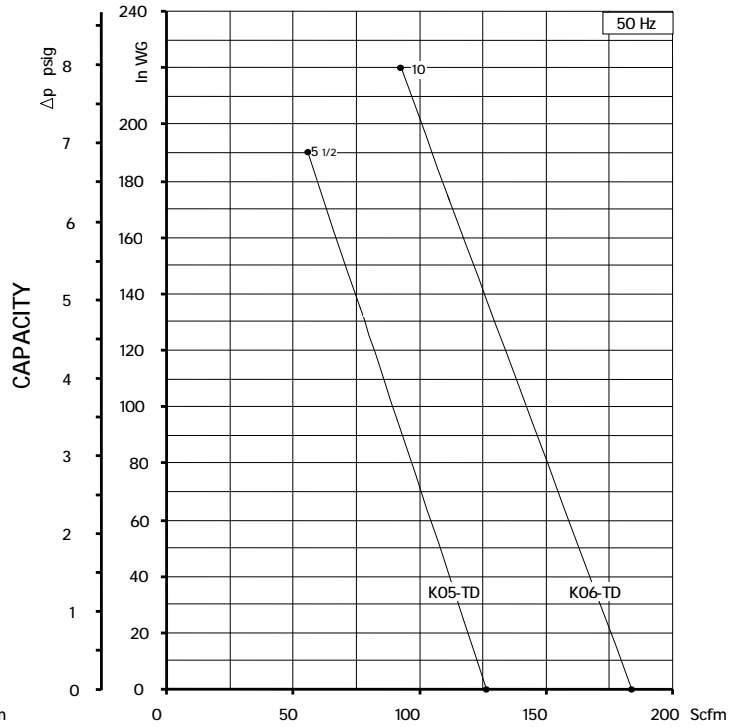
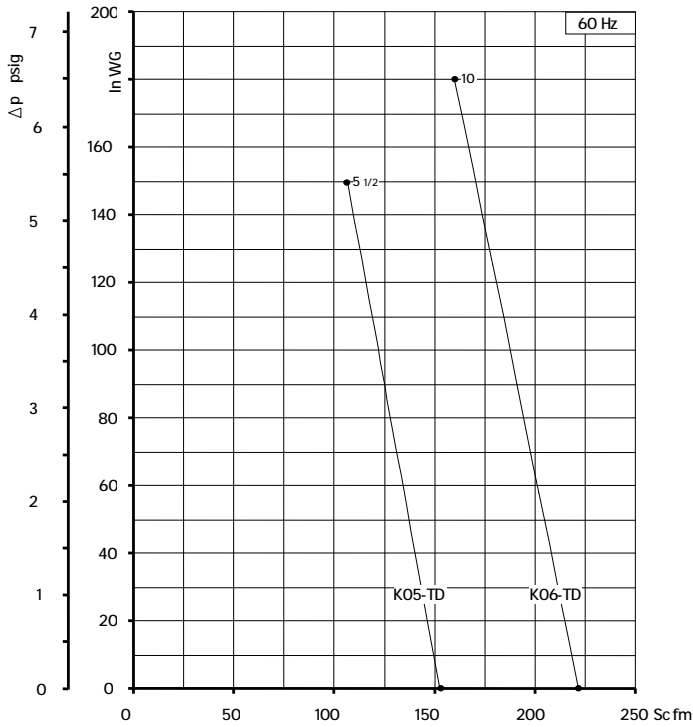

Curves refer to air at 68°F temperature and 29.92 In Hg atmospheric pressure (abs) measured at inlet port.  
 Values for flow, power consumption and temperature rise +/-10% tolerance.  
 Data subject to change without notice.



**TECHNICAL CHARACTERISTICS**

- Aluminium alloy construction
- Smooth operation
- High efficiency impeller
- Maintenance free
- Mountable in any position
- Recognized TEFC - cURus motor
- G1/8" female thread on both suction and discharge silencer port flanges

**OPTIONS**

- Special voltages (IEC 38)
- Surface treatments

**ACCESSORIES**

- Inlet and/or inline filters
- Additional inlet/outlet silencers
- Safety valves
- Flow converting device
- Optional connectors

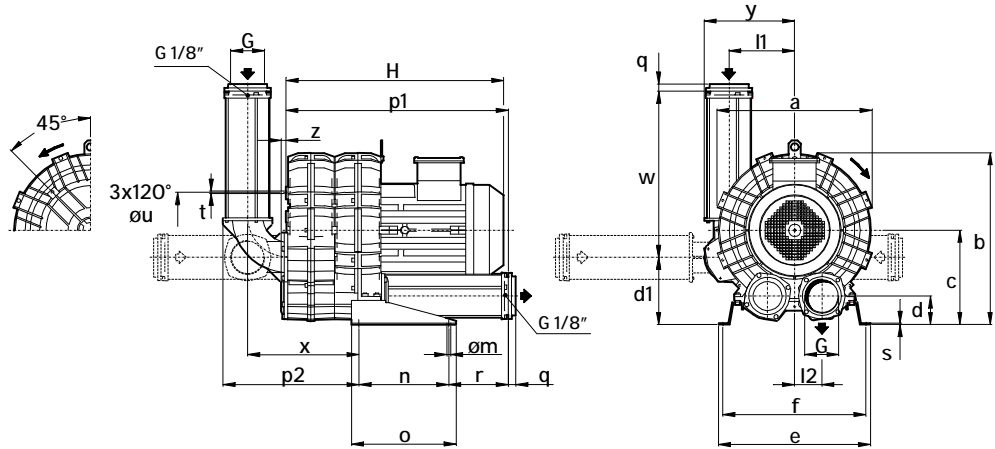

Dimensions in inches.  
Dimension for reference only.

Model	a	b	c	d	d1	e	f	G	l1	l2	m	n	o	p1	p2	q	r	s	t	u	w	x	y	z
K09-TD	19.37	22.09	12.4	3.78	8.86	20.00	18.82	4"NPT	8.66	3.58	0.51	11.81	13.78	29.33	17.91	0.98	7.83	0.20	M8	14.17	21.89	14.65	11.89	0.63
K10-TD	20.31	22.56	12.4	3.78	8.86	20.00	18.82	4"NPT	8.66	3.58	0.51	11.81	13.78	29.33	17.91	0.98	7.83	0.20	M8	14.17	21.89	14.65	11.89	0.63

Model	Maximum flow Scfm		Installed power Hp		Maximum differential pressure Δp (In WG)		Noise level Lp dB (A) <sup>(1)</sup>		Overall dimensions H	Weight
	60 Hz	50 Hz	60 Hz	50 Hz	60 Hz	50 Hz	60 Hz	50 Hz		
	3500 rpm	2900 rpm	3500 rpm	2900 rpm	3500 rpm	2900 rpm	3500 rpm	2900 rpm	Inches	Lbs
K09-TD	467	387	25	25	220	240	83.3	81.3	30.0	406.0
K10-TD	571	473	25	25	180	231	87.2	85.2	30.0	416.0

(1) Noise measured at 1 m distance with inlet and outlet ports piped, in accordance to ISO 3744.

- For proper use, the blower should be equipped with inlet filter and safety valve; other accessories available on request.
- Ambient temperature from +5° to +104F.
- Specifications subject to change without notice.

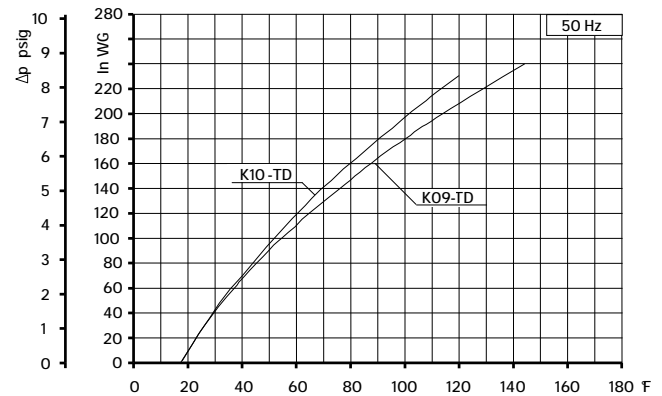
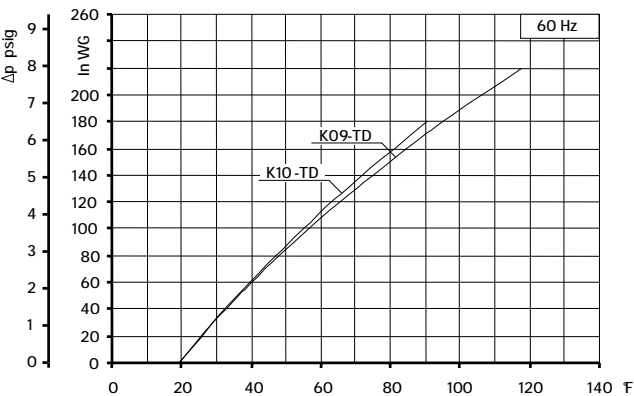
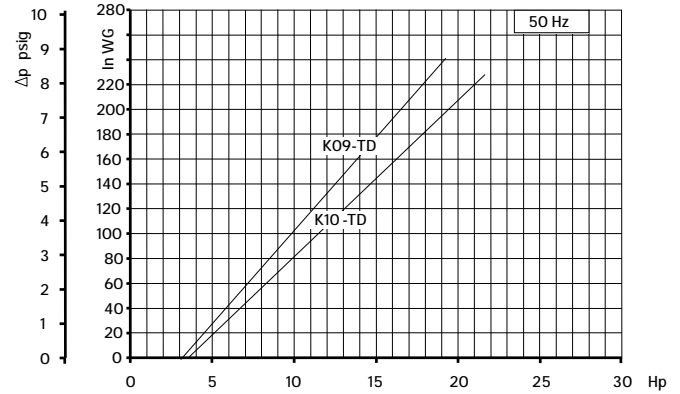
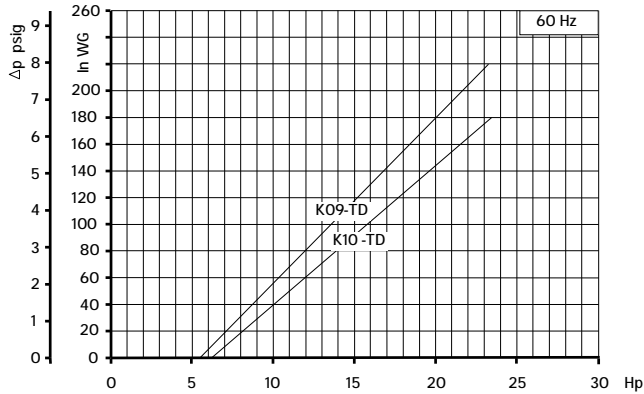
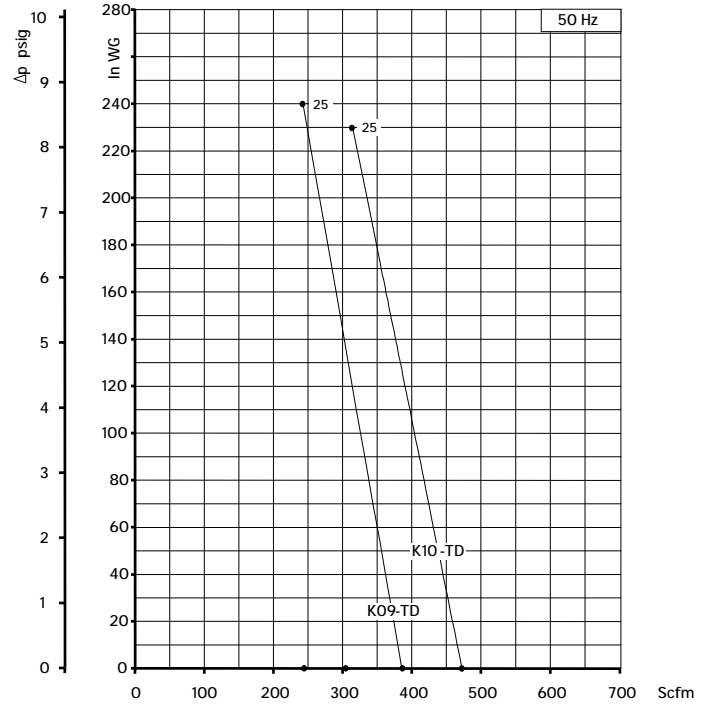
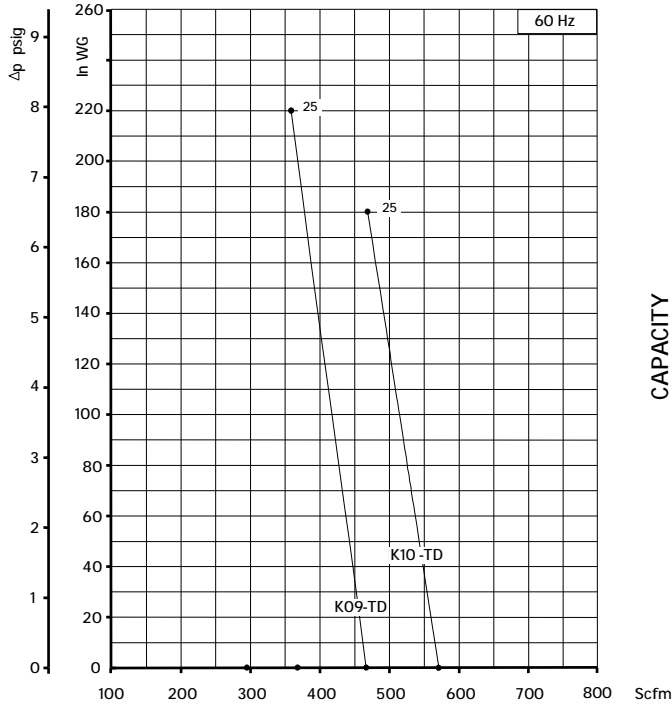

Curves refer to air at 68°F temperature and 29.92 In Hg atmospheric pressure (abs) measured at inlet port.  
 Values for flow, power consumption and temperature rise: +/-10% tolerance.  
 Data subject to change without notice.





**STANDARD FEATURES**

- Low weight cast aluminum construction.
- Quiet operation with integral inlet and outlet muffling.
- Recognized TEFC - cURus motor.
- High efficiency / low noise impeller design.
- No lubrication / maintenance required.
- Allowed ambient: +5 °F to +104 °F.
- Mountable in any plane.

**OPTIONS**

- Special voltages.
- Surface treatment or plating.
- Gas tight sealing.
- Special designs available.

**ACCESSORIES**

- Inlet and/or inline filters.
- Additional inlet/outlet silencers.
- Safety valves.
- Flow converting devices.
- Optionals connectors

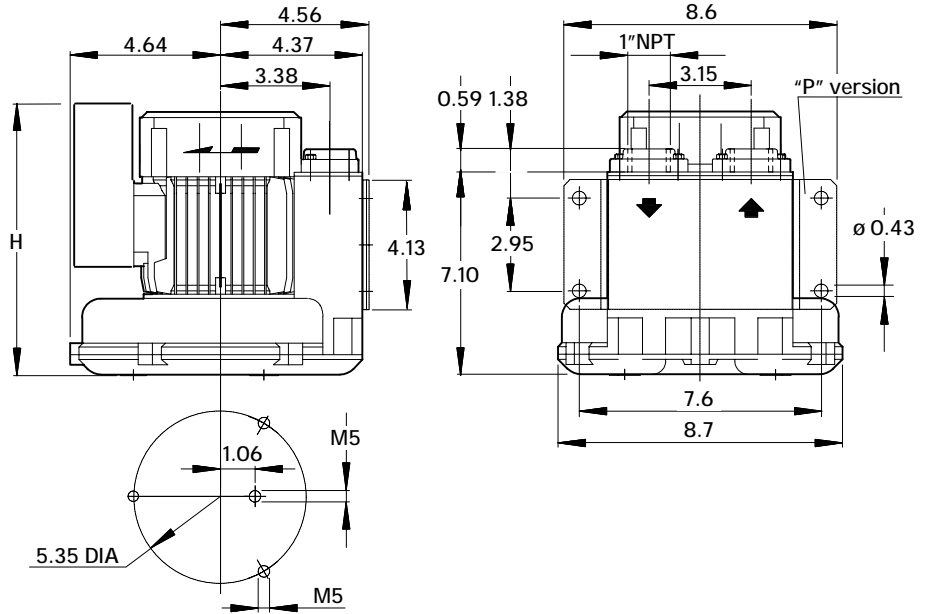

Dimensions in inches.  
Dimension for reference only.

Model	Maximum flow Scfm		Installed power Hp		Maximum differential pressure $\Delta p$ (In WG)		Noise level Lp dB (A) (1)		Overall dimensions H Inches	Weight Lbs
	60 Hz 3500 rpm	50 Hz 2900 rpm	60 Hz 3500 rpm	50 Hz 2900 rpm	60 Hz 3500 rpm	50 Hz 2900 rpm	60 Hz 3500 rpm	50 Hz 2900 rpm		
06	39	32	1/3	-	36	-	58.7	-	10.60	18.30
			1/2	1/2	52	36	59.0	58.0	10.60	18.50

(1) Noise measured at 1 m distance with inlet and outlet ports piped, in accordance to ISO 3744.

- For proper use, the blower should be equipped with inlet filter and safety valve; other accessories available on request.
- Ambient temperature from +5° to +104°F.
- Specifications subject to change without notice.

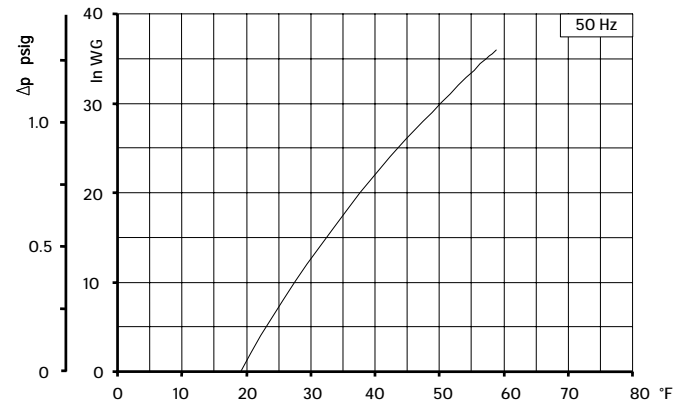
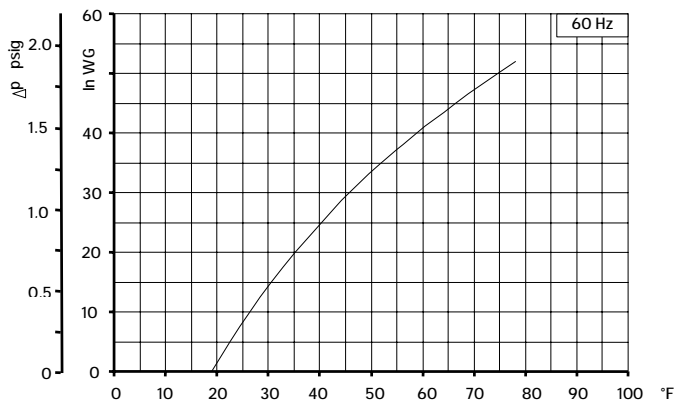
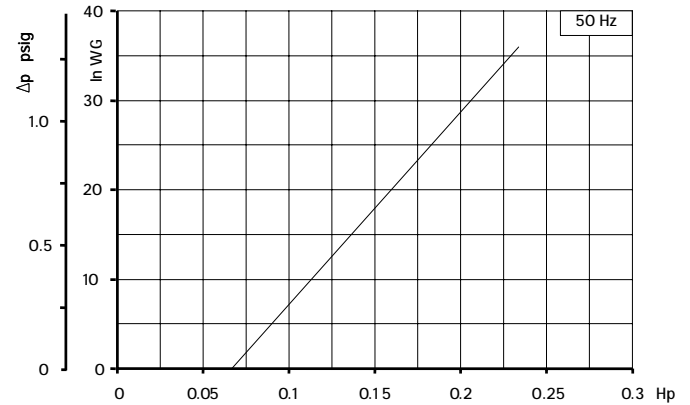
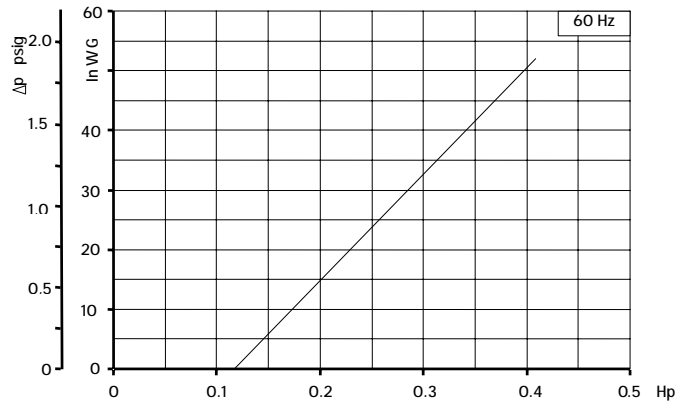
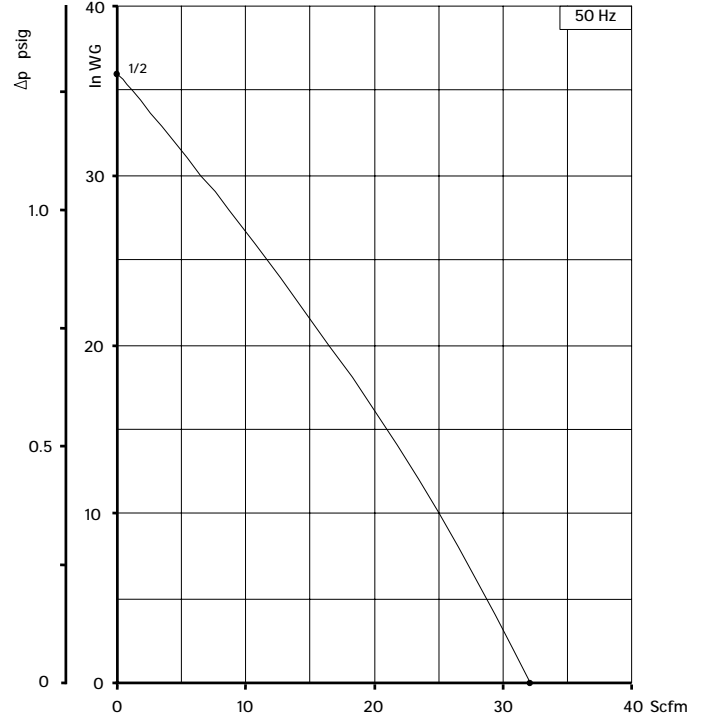
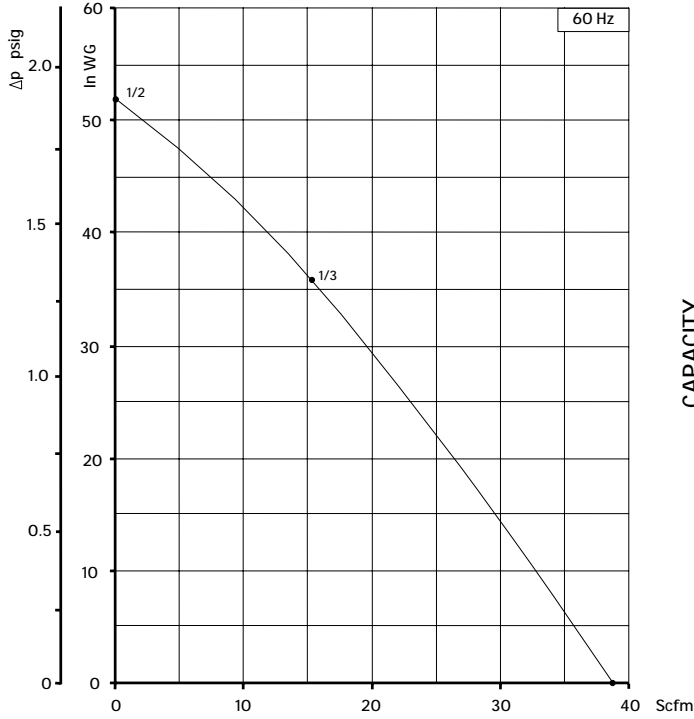

Curves refer to air at 68°F temperature and 29.92 In Hg atmospheric pressure (abs) measured at inlet port.  
Values for flow, power consumption and temperature rise: +/-10% tolerance.  
Data subject to change without notice.



**STANDARD FEATURES**

- Low weight cast aluminum construction.
- Quiet operation with integral inlet and outlet muffling.
- Recognized TEFC - cURus motor.
- High efficiency / low noise impeller design.
- No lubrication / maintenance required.
- Allowed ambient: +5 °F to +104 °F.
- Mountable in any plane.

**OPTIONS**

- Remote drive models (belt or coupling).
- Special voltages.
- Surface treatment or plating.
- Gas tight sealing.
- Special designs available.

**ACCESSORIES**

- Inlet and/or inline filters.
- Additional inlet/outlet silencers.
- Safety valves.
- Flow converting devices.
- Optionals connectors

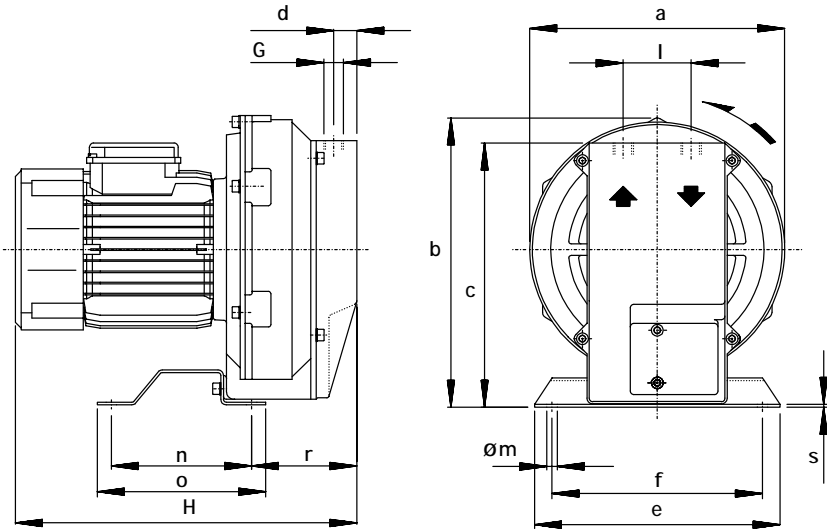

Dimensions in inches.  
Dimension for reference only.

Model	a	b	c	d	e	f	G	l	m	n	o	r	s
15DH-MD	9.84	11.26	10.16	1.18	8.27	7.09	3/4"NPT	2.52	0.35	4.72	5.67	4.72	0.10

Model	Maximum flow Scfm		Installed power Hp		Maximum differential pressure Δp (In WG)		Noise level Lp dB (A) <sup>(1)</sup>		Overall dimensions H Inches	Weight Lbs
	60 Hz 3500 rpm	50 Hz 2900 rpm	60 Hz 3500 rpm	50 Hz 2900 rpm	60 Hz 3500 rpm	50 Hz 2900 rpm	60 Hz 3500 rpm	50 Hz 2900 rpm		
15DH-MD	35	29	3/4	3/4	98	105	63.7	61.7	14.25	32.50
			1	1	120.5	120.5	64.0	62.0	15.75	40.00

(1) Noise measured at 1 m distance with inlet and outlet ports piped, in accordance to ISO 3744.

- For proper use, the blower should be equipped with inlet filter and safety valve; other accessories available on request.
- Ambient temperature from +5° to +104°F.
- Specifications subject to change without notice.

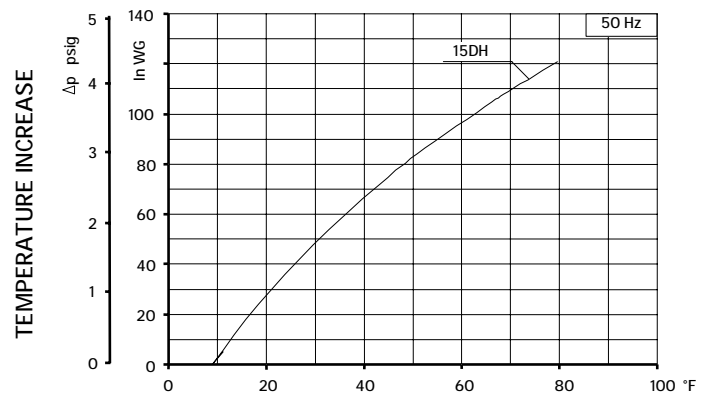
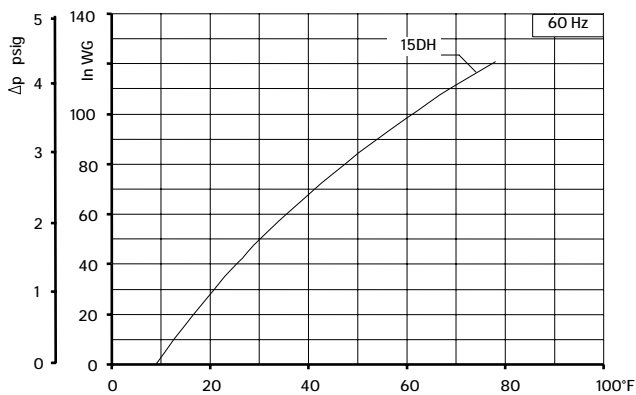
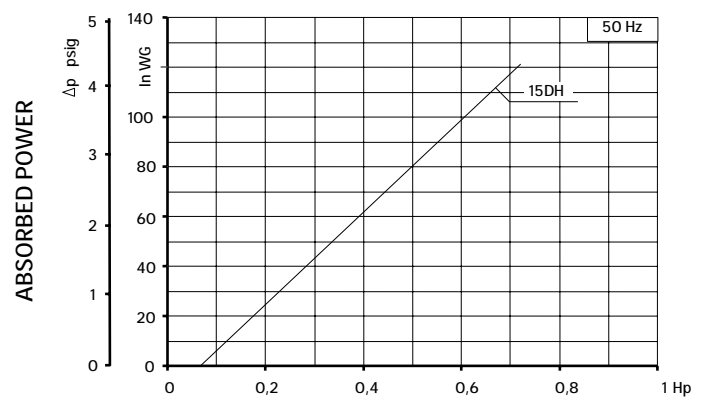
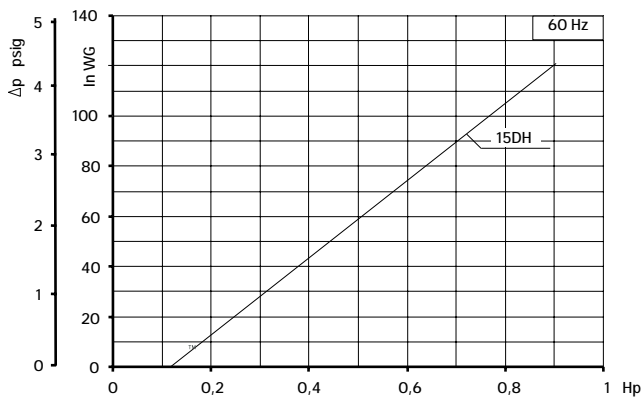
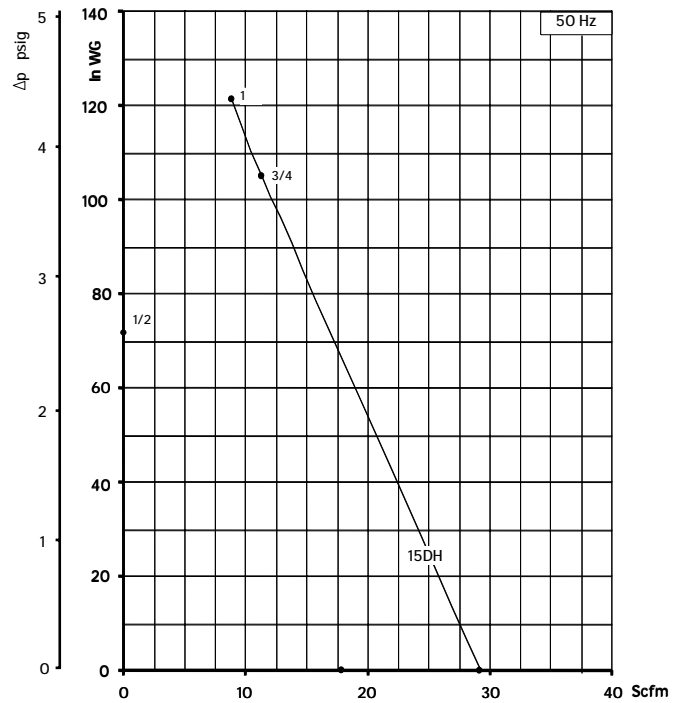
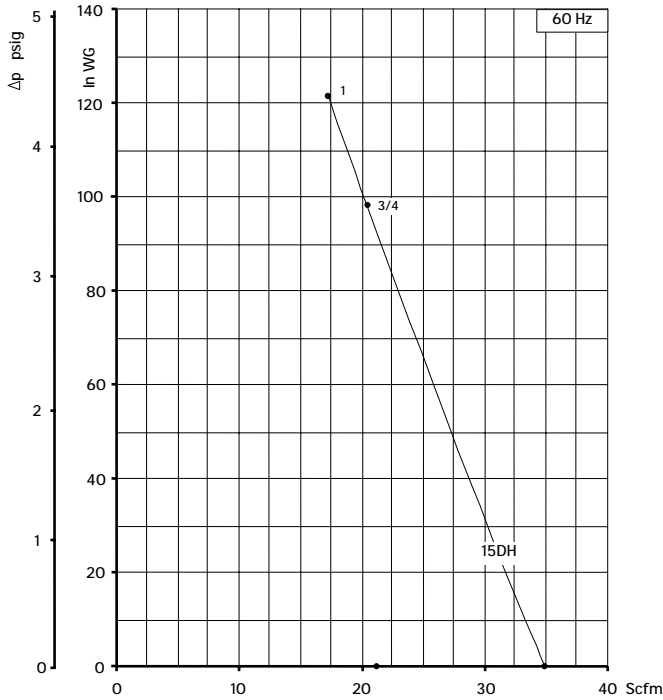

Curves refer to air at 68°F temperature and 29.92 In Hg atmospheric pressure (abs) measured at inlet port.  
Values for flow, power consumption and temperature rise: +/-10% tolerance.  
Data subject to change without notice.



**STANDARD FEATURES**

- Low weight cast aluminum construction.
- Quiet operation with integral inlet and outlet muffling.
- Recognized TEFC - cURus motor.
- High efficiency / low noise impeller design.
- No lubrication / maintenance required.
- Allowed ambient: +5 °F to +104 °F.
- Mountable in any plane.

**OPTIONS**

- Remote drive models (belt or coupling).
- Special voltages.
- Surface treatment or plating.
- Gas tight sealing.
- Special designs available.

**ACCESSORIES**

- Inlet and/or inline filters.
- Additional inlet/outlet silencers.
- Relief valves.
- Flow converting devices.
- Optionals connectors

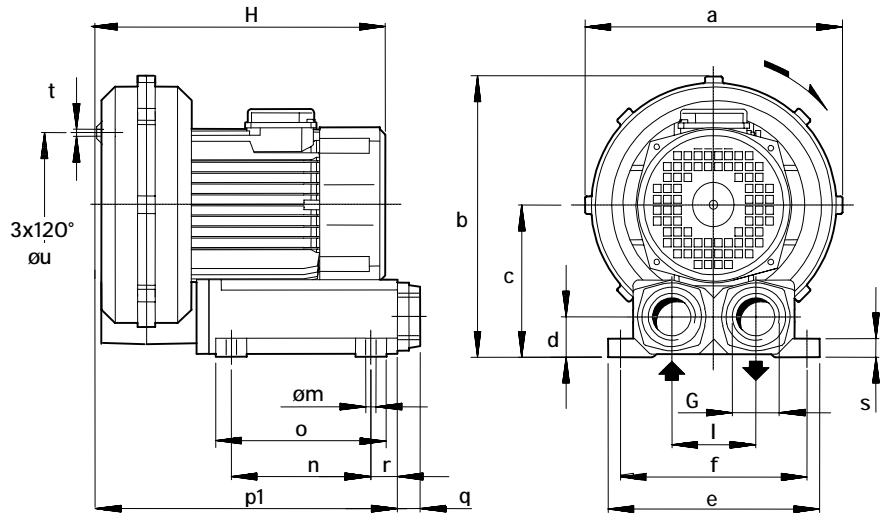

Dimensions in inches.  
Dimension for reference only.

Model	a	b	c	d	e	f	G	l	m	n	o	p1	q	r	s	t	u
R20-MD	11.14	12.17	6.57	1.85	9.25	8.27	1" ¼ NPT	3.54	0.39	5.91	7.87	13.58	0.71	1.77	0.87	M6	5.91
R30-MD	12.56	13.62	7.36	1.85	9.25	8.27	1" ¼ NPT	3.54	0.39	5.91	7.87	13.94	0.71	1.77	0.87	M6	7.09
R40-MD	13.78	14.65	7.76	1.85	9.25	8.27	1" ¼ NPT	3.54	0.39	5.91	7.87	14.33	0.71	1.77	0.87	M8	8.86

Model	Maximum flow Scfm		Installed power Hp		Maximum differential pressure Δp (In WG)		Noise level Lp dB (A) <sup>(1)</sup>		Overall dimensions H	Weight
	60 Hz	50 Hz	60 Hz	50 Hz	60 Hz	50 Hz	60 Hz	50 Hz		
	3500 rpm	2900 rpm	3500 rpm	2900 rpm	3500 rpm	2900 rpm	3500 rpm	2900 rpm	Inches	Lbs
R20-MD	41	35	1 ½	1 ½	161	161	68.5	66.5	13.39	48.5
R30-MD	65	54	2	2	140	170	72.2	69.2	15.58	57.3
			3	-	191	-	72.8	69.7	15.55	66.1
R40-MD	78	69	3	3	141	170	72.8	70.8	16.22	77.2
			4	4	201	201	73.3	71.3	17.09	88.2

(1) Noise measured at 1 m distance with inlet and outlet ports piped, in accordance to ISO 3744.

- For proper use, the blower should be equipped with inlet filter and relief valve; other accessories available on request.
- Ambient temperature from +5° to +104°F.
- Specifications subject to change without notice.



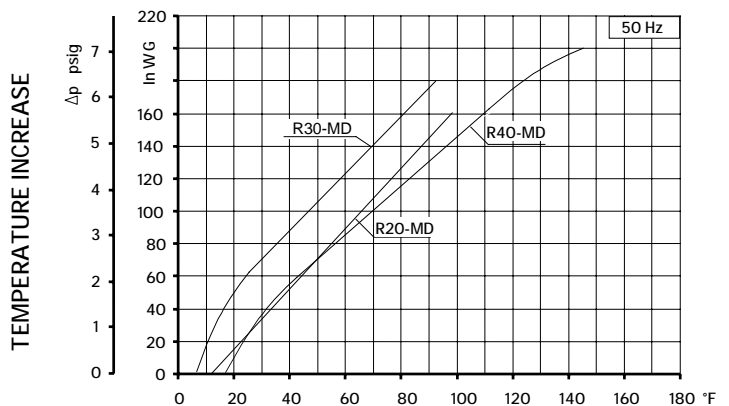
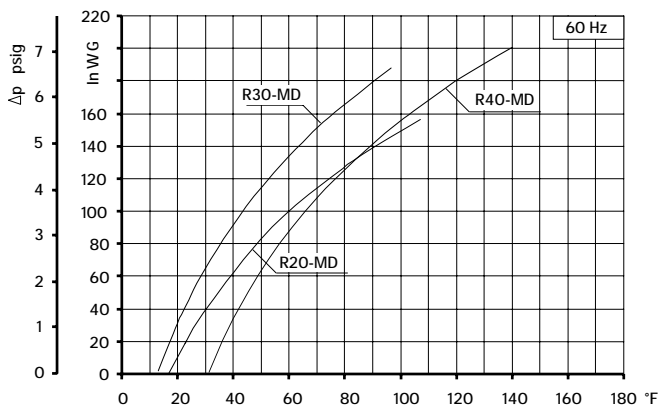
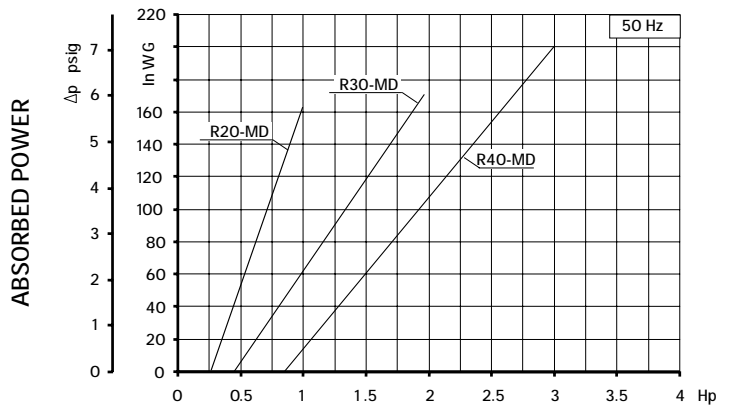
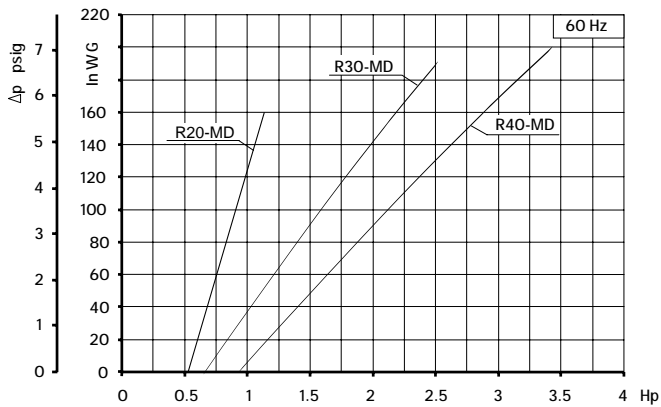
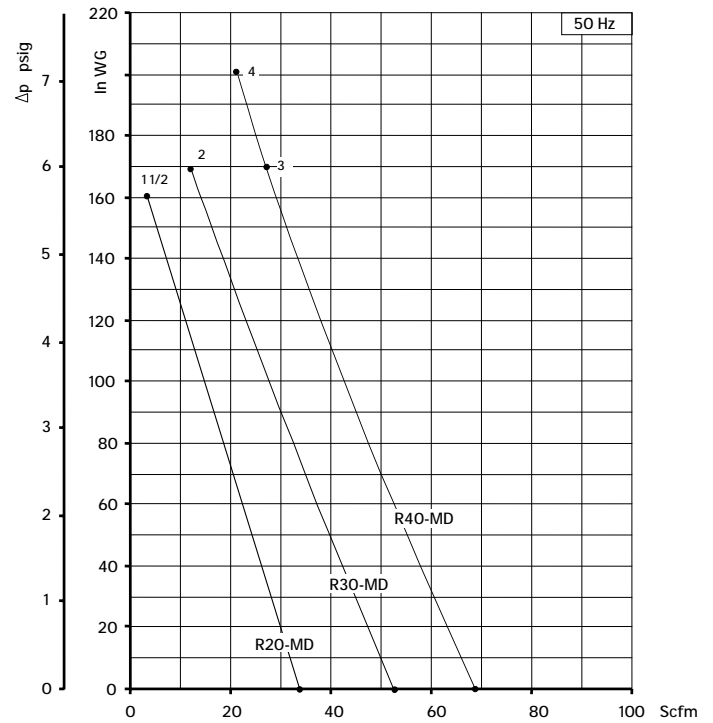
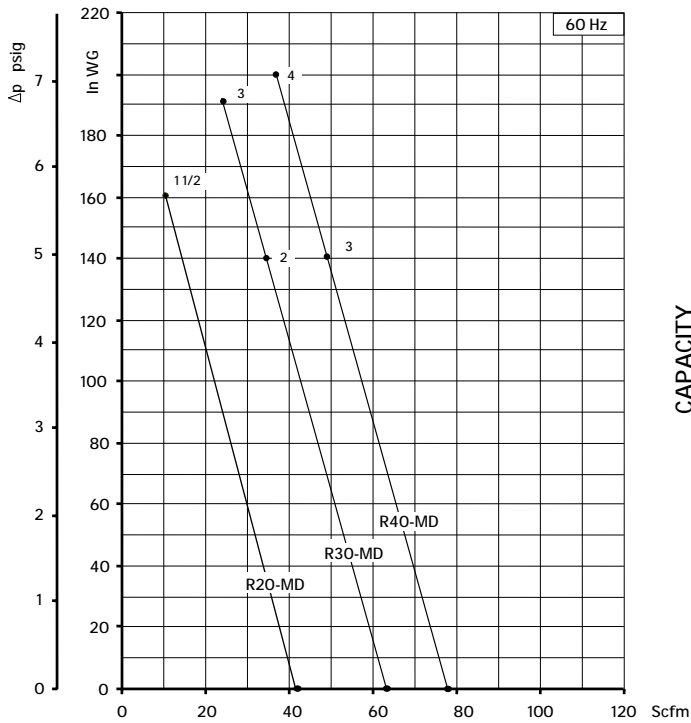

Curves refer to air at 68°F temperature and 29.92 In Hg atmospheric pressure (abs) measured at inlet port.  
 Values for flow, power consumption and temperature rise: +/-10% tolerance.  
 Data subject to change without notice.



SCL K03 / K04 / K05 / K06  
MS SERIES - GOR/GVR RANGE  
SN 2580-2 1/2

TECHNICAL CHARACTERISTICS

- Aluminium alloy construction
- Smooth operation
- High efficiency impeller
- Maintenance free
- Mountable in any position

OPTIONS

- Special voltages (IEC 38)
- Surface treatments

ACCESSORIES

- Inlet and/or inline filters
- Additional inlet/outlet silencers
- Safety valves
- Flow converting device
- Optional connectors

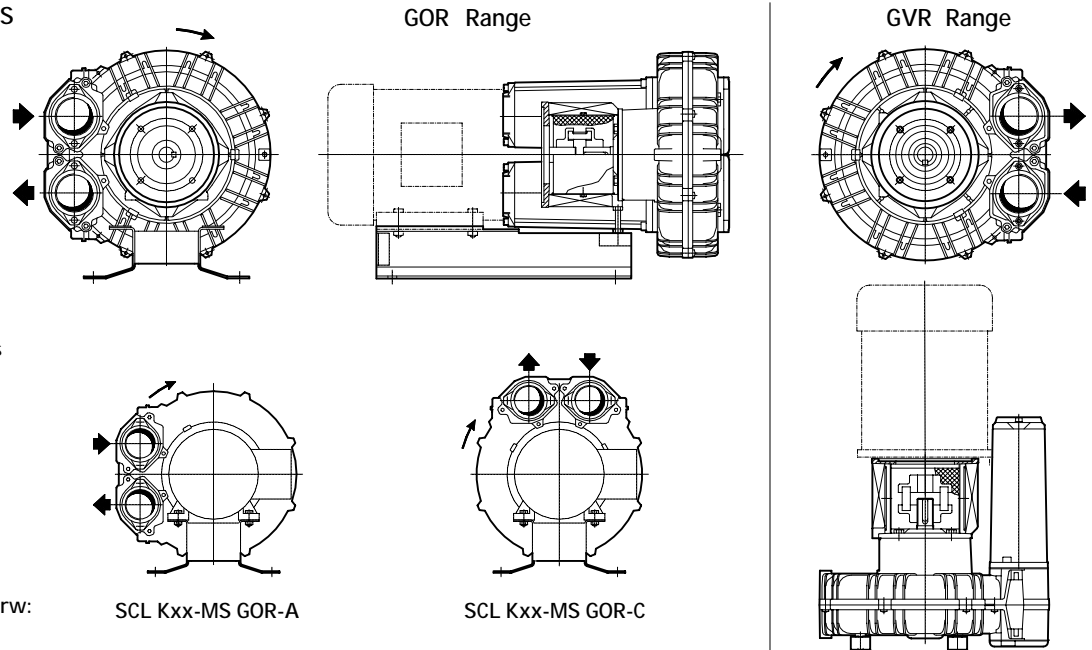

For dimensions, please refer to drw:  
- GOR range: SI 1852  
- GVR range: SI 1946

Model	Maximum flow Scfm		Installed power Hp	Size	Maximum differential pressure $\Delta p$ (In WG)		Noise level Lp dB (A) <sup>(1)</sup>		Weight <sup>(2)</sup>	
	60 Hz	50 Hz			60 Hz	50 Hz	60 Hz	50 Hz	Lbs	
	3500 rpm	2900 rpm			3500 rpm	2900 rpm	3500 rpm	2900 rpm	GOR	GVR
K03-MS	52	43	3/4	NEMA 56C	64	60	62.0	60.0	22.00	17.60
			1	NEMA 56C	80		62.3			
K04-MS	98	81	1 1/2	NEMA 56C	58	80	64.8	62.8	27.60	22.00
			2	NEMA 56C	85	90	65.0			
			3	NEMA 56C	100		65.2			
K05-MS	156	129	2	NEMA 143-5TC	52	70	70.5	68.5	35.00	28.00
			3	NEMA 143-5TC	90	110	70.8		68.8	
			5	NEMA 182-4TC			130	120		71.1
K06-MS	216	179	3	NEMA 143-5TC	50	65	73.0	71.0	46.00	38.40
				NEMA 182-4TC						
			5	NEMA 182-4TC	85	110	73.6	71.6	40.80	38.00
7 1/2	NEMA 182-4TC	140	135	73.9	71.9					

(1) Noise measured at 1 m distance with inlet and outlet ports piped, in accordance to ISO 3744.  
(2) Value is referred to weight of the machine without electric motor.

- For proper use, the blower should be equipped with inlet filter and safety valve; other accessories available on request.
- Ambient temperature from +5° to +104°F.
- Specifications subject to change without notice.



SCL K03 / K04 / K05 / K06  
MS SERIES - GOR/GVR RANGE

SN 2580-2 2/2

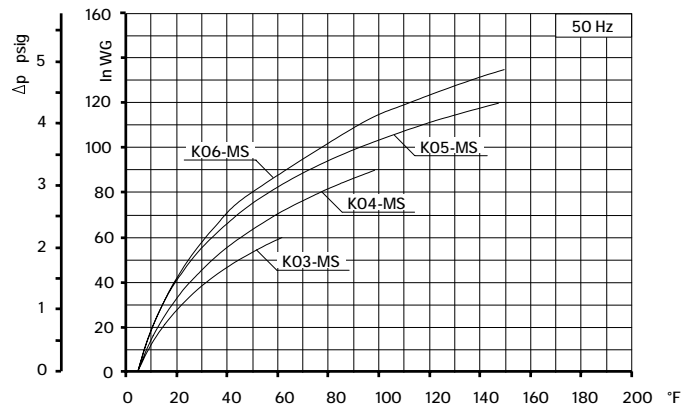
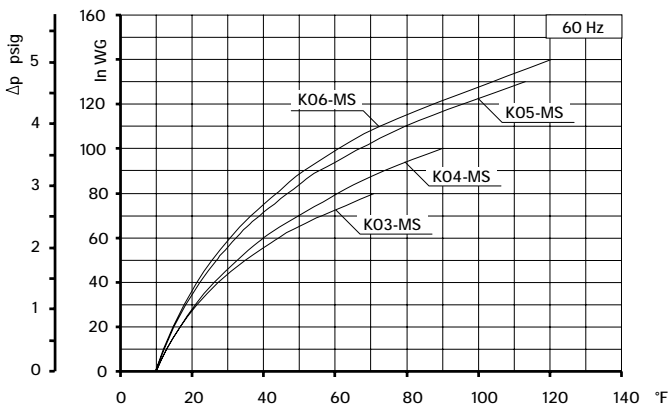
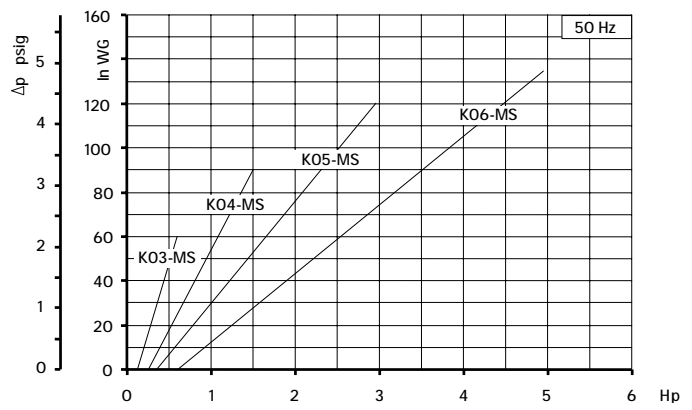
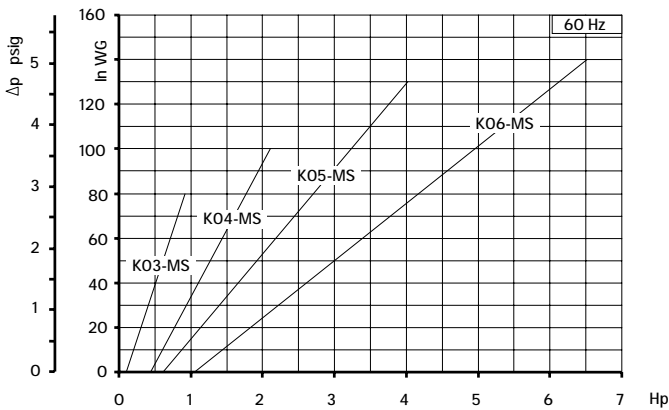
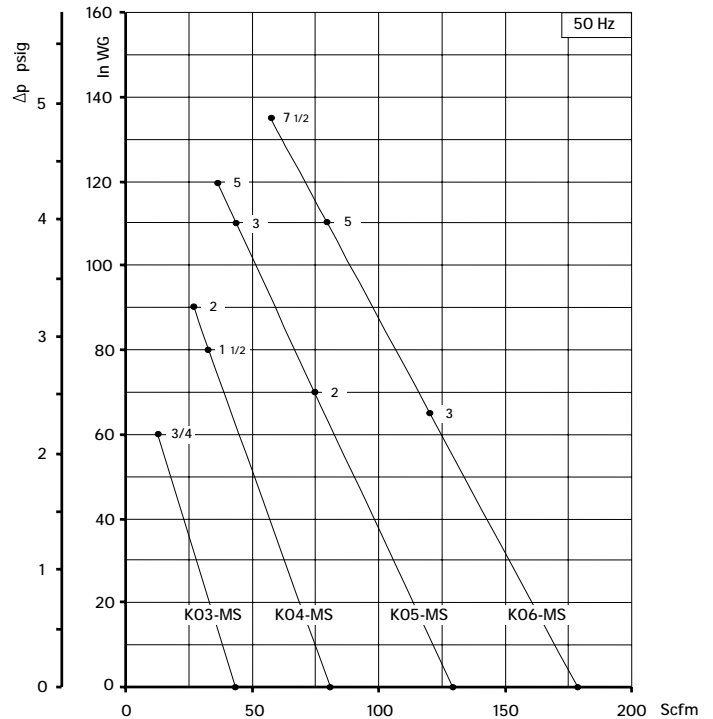
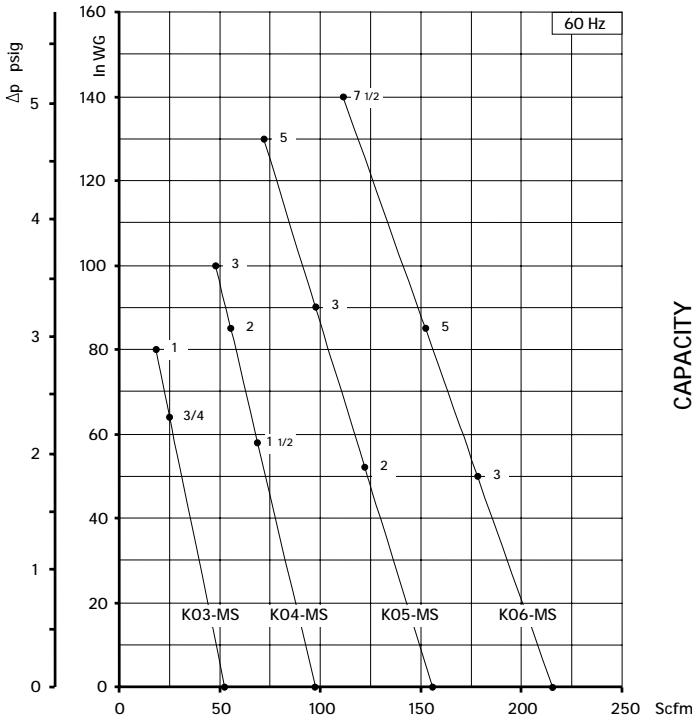

Curves refer to air at 68°F temperature and 29.92 In Hg atmospheric pressure (abs) measured at inlet port.  
Values for flow, power consumption and temperature rise: +/-10% tolerance.  
Data subject to change without notice.



SCL K09 / K10  
MS SERIES - GOR/GVR RANGE  
SN 2134-6 1/2

TECHNICAL

CHARACTERISTICS

- Aluminium alloy construction
- Smooth operation
- High efficiency impeller
- Maintenance free
- Mountable in any position

OPTIONS

- Special voltages (IEC 38)
- Surface treatments

ACCESSORIES

- Inlet and/or inline filters
- Additional inlet/outlet silencers
- Safety valves
- Flow converting device
- Optional connectors

For dimensions, please refer to drw:

GOR range: SI 1873

GVR range: SI 1920

GOR Range

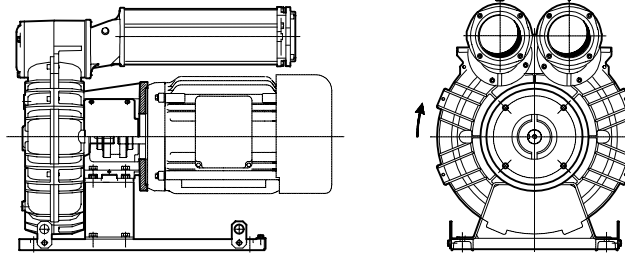

SCL Kxx-MS GOR-C

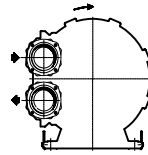

SCL Kxx-MS GOR-A

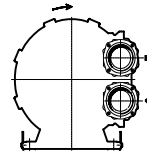

SCL Kxx-MS GOR-B

GVR Range

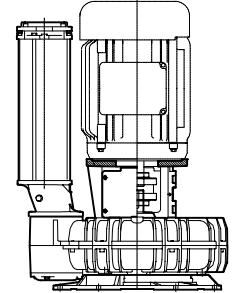
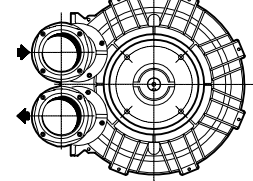

Model	Maximum flow Scfm		Installed power Hp	Size	Maximum differential pressure Δp (in WG)		Noise level Lp dB (A) <sup>(1)</sup>		Weight <sup>(2)</sup> Lbs
	60 Hz 3500 rpm	50 Hz 2900 rpm			60 Hz 3500 rpm	50 Hz 2900 rpm	60 Hz 3500 rpm	50 Hz 2900 rpm	
	K09-MS	471			390	7 1/2	NEMA 182-4TC	50	
			NEMA 213-5TC	133.4					
10			NEMA 213-5TC	80		95	80.5	78.5	133.4
15			NEMA 213-5TC	140		155	81.0	79.0	133.4
			NEMA 254-6TC						137.0
20	NEMA 254-6TC	180	170	81.3	79.3	137.0			
K10-MS	556	460	7 1/2	NEMA 182-4TC	30	50	80.1	78.1	147.3
				NEMA 213-5TC					147.3
			10	NEMA 213-5TC	60	80	80.5	78.5	147.3
			15	NEMA 213-5TC	110	135	81.0	79.0	147.3
				NEMA 254-6TC					151.0
			20	NEMA 254-6TC	160	190	81.4	79.4	151.0
			25	NEMA 284-6TSC	200		81.6		147.3

(1) Noise measured at 1 m distance with inlet and outlet ports piped, in accordance to ISO 3744.

- Specifications subject to change without notice.

(2) Value is referred to weight of the machine without electric motor

- For proper use, the blower should be equipped with inlet filter and safety valve; other accessories available on request.
- Ambient temperature from +5° to +104°F.



SCL K09 / K10  
MS SERIES - GOR/GVR RANGE  
SN 2134-6 2/2

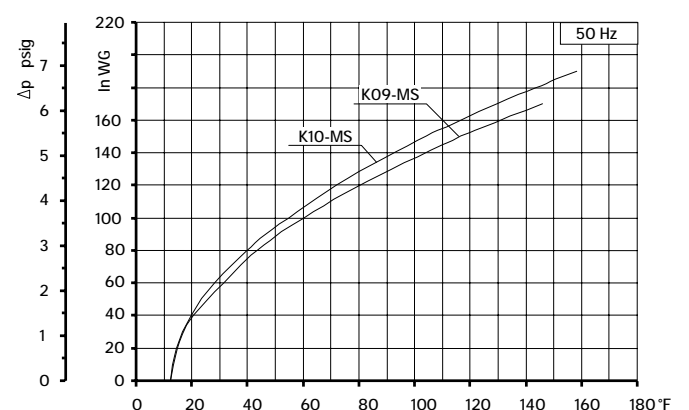
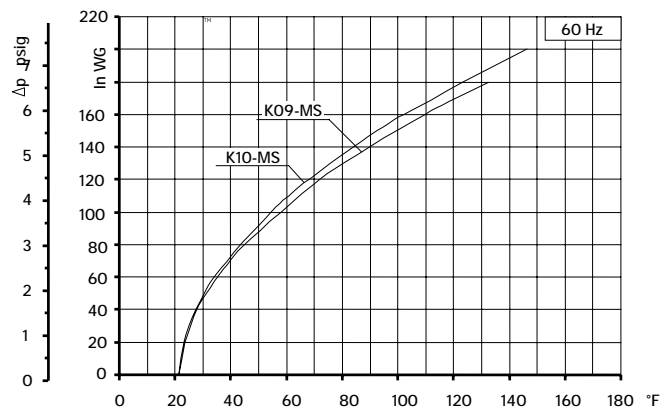
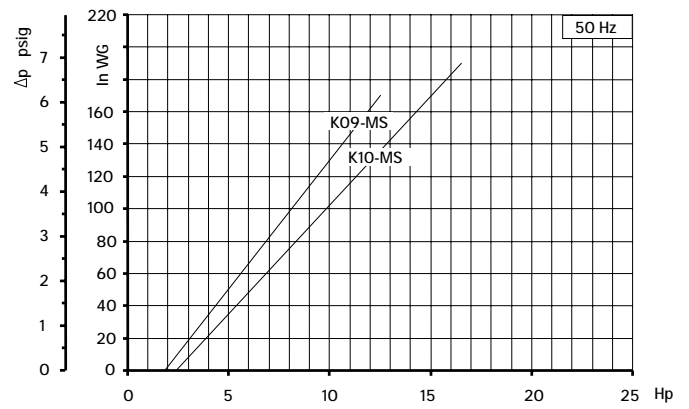
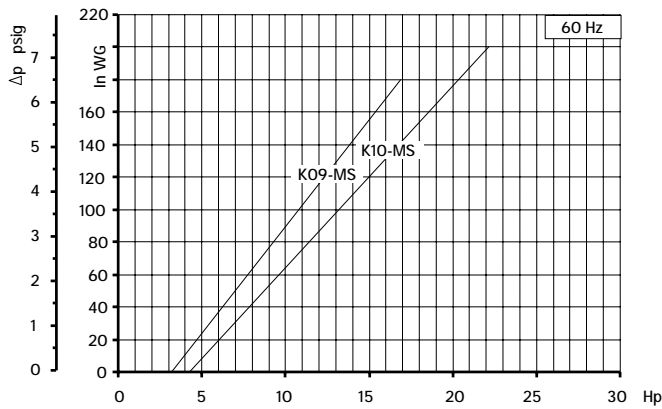
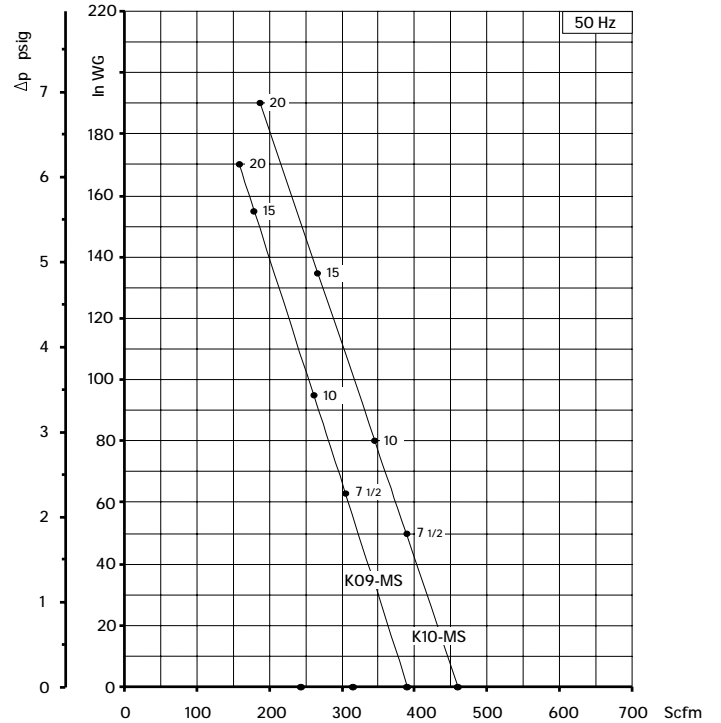
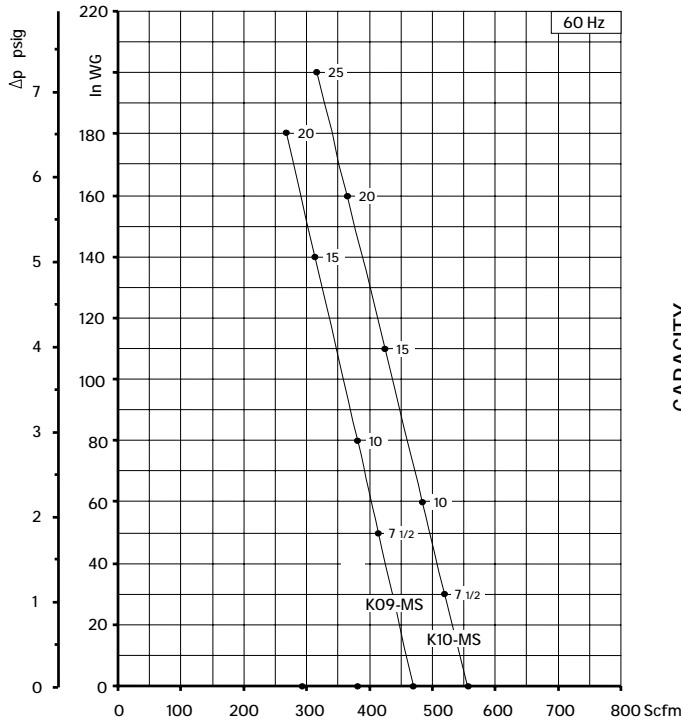

Curves refer to air at 68°F temperature and 29.92 In Hg atmospheric pressure (abs) measured at inlet port.  
Values for flow, power consumption and temperature rise: +/-10% tolerance.  
Data subject to change without notice.



TECHNICAL CHARACTERISTICS

- Aluminium alloy construction
- Smooth operation
- High efficiency impeller
- Maintenance free
- Mountable in any plane
- G1/8" female thread on both suction and discharge silencer port flanges.

OPTIONS

- Special voltages (IEC 38)
- Surface treatments

ACCESSORIES

- Inlet and/or inline filters
- Additional inlet/outlet silencers
- Safety valves
- Flow converting device
- Optional connectors

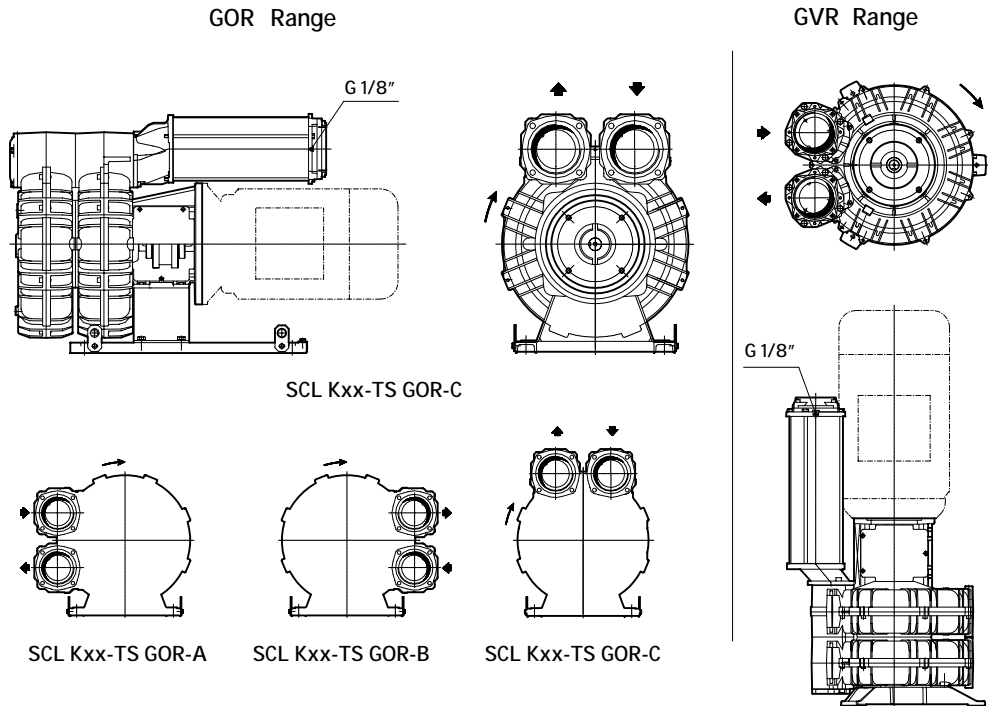

For dimensions, please refer to drw:

- GOR range: SI 21 23
- GVR range: SI 21 35

Model	Maximum flow m <sup>3</sup> /h		Installed power Hp	Size	Maximum differential pressure Δp (in WG)		Noise level Lp dB (A) (1)		Weight (2)	
	60 Hz 3500 rpm	50 Hz 2900 rpm			60 Hz 3500 rpm	50 Hz 2900 rpm	60 Hz 3500 rpm	50 Hz 2900 rpm	Lbs	
							GOR	GVR		
K05-TS	290	241	5.0	NEMA 182-4TC	60	85	75.5	73.5	72.75	68.35
			7.5		100	110	77.5	75.5		
K06-TS	400	331	7.5	NEMA 213-5TC	55	77	77.5	75.5	112.45	108.00
			10		80	110	77.8	75.8		
			15		130	120	78.4	76.4		

(1) Noise measured at 1 m distance with inlet and outlet ports piped, in accordance to ISO 3744.  
 (2) Value is referred to weight of the machine without electric motor.

- For proper use, the blower should be equipped with inlet filter and safety valve; other accessories available on request.
- Ambient temperature from +5° to +104°F.
- Specifications subject to change without notice.



SCL K05 / K06  
TS SERIES - GOR/GVR RANGE

SN 2686-2 2/2

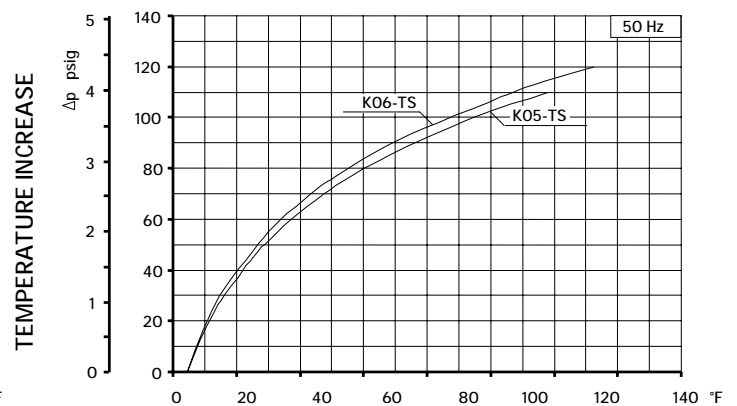
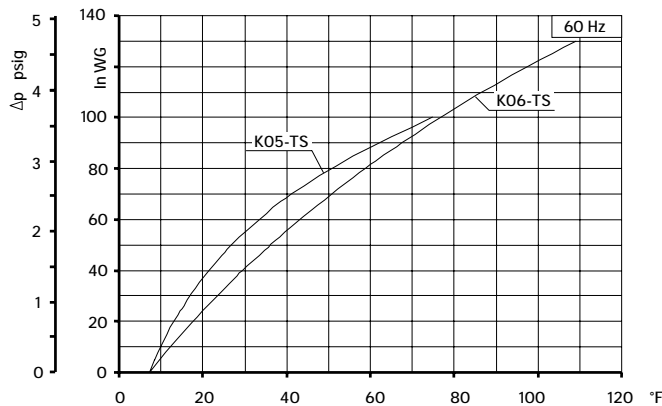
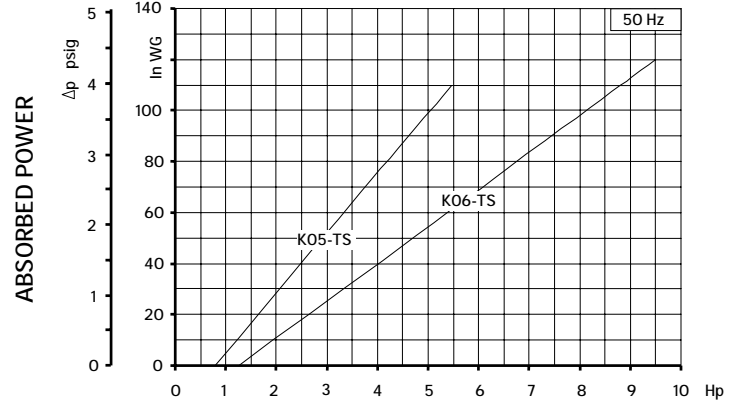
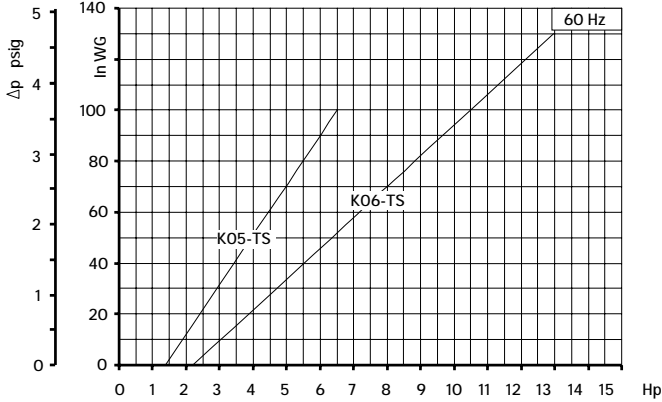
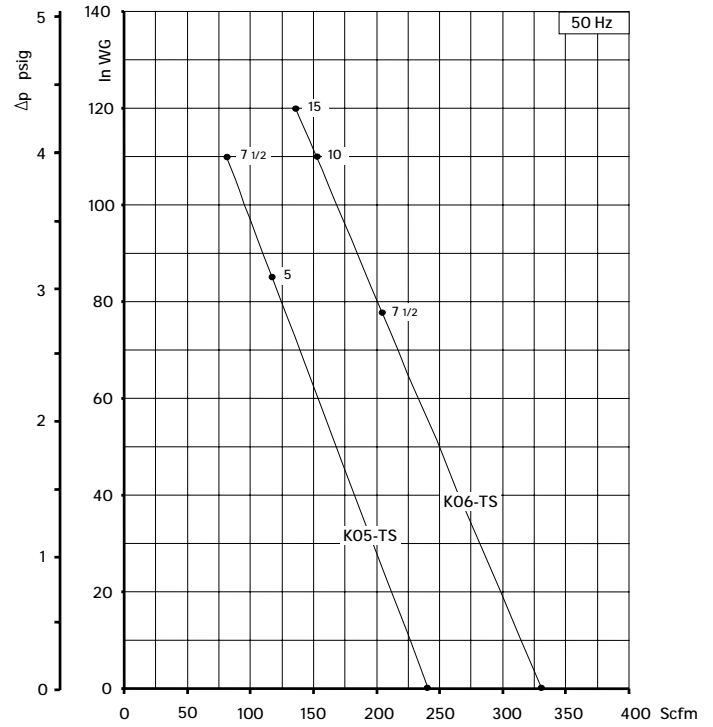
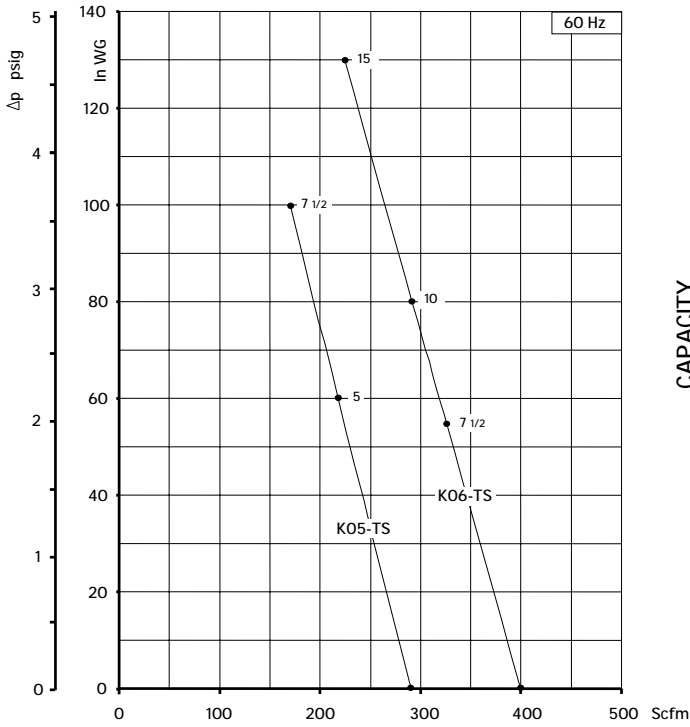

Curves refer to air at 68°F temperature and 29.92 In Hg atmospheric pressure (abs) measured at inlet port.  
Values for flow, power consumption and temperature rise: +/-10% tolerance.  
Data subject to change without notice.



SCL K09 / K10  
TS SERIES - GOR/GVR RANGE  
SN 2164-8 1/2

TECHNICAL CHARACTERISTICS

- Aluminium alloy construction
- Smooth operation
- High efficiency impeller
- Maintenance free
- Mountable in any position
- G1/8" female thread on both suction and discharge silencer port flanges

OPTIONS

- Special voltages (IEC 38)
- Surface treatments

ACCESSORIES

- Inlet and/or inline filters
- Additional inlet/outlet silencers
- Safety valves
- Flow converting device
- Optional connectors

For dimensions, please refer to drw:

GOR range: SI 1879

GVR range: SI 1880

GOR RANGE

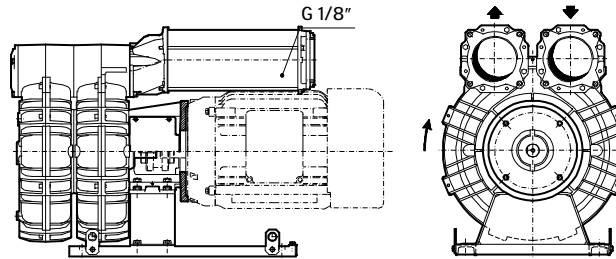

SCL Kxx-TS GOR-C

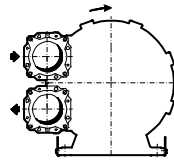

SCL Kxx-TS GOR-A

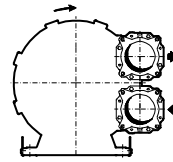

SCL Kxx-TS GOR-B

GVR RANGE

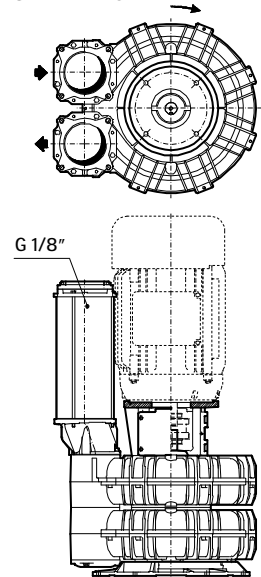

Model	Maximum flow Scfm		Installed power Hp	Size	Maximum differential pressure $\Delta p$ (In WG)		Noise level Lp dB (A) (1)		Weight (2) Lbs
	60 Hz 3500 rpm	50 Hz 2900 rpm			60 Hz 3500 rpm	50 Hz 2900 rpm	60 Hz 3500 rpm	50 Hz 2900 rpm	
	K09-TS	941			780	15	NEMA 213-5TC	52	
			NEMA 254-6TC	52		75	83.0	81.0	208.30
20			NEMA 254-6TC	80		108	85.0	83.0	208.30
25			NEMA 284-6TSC	110		145	87.0	85.0	205.00
30			NEMA 284-6TSC	120		160	89.0	87.0	205.00
			40	NEMA 324-6TSC	150	160	91.0	87.0	220.50
K10-TS	1093	906	15	NEMA 213-5TC	41	64	87.8	85.8	209.40
				NEMA 254-6TC	41	64	87.8	85.8	216.10
			20	NEMA 254-6TC	65	90	88.1	86.1	216.10
			25	NEMA 284-6TSC	80	110	88.4	86.4	211.60
			30	NEMA 284-6TSC	100	140	88.7	86.7	211.60
			40	NEMA 324-6TSC	150	160	89.0	87.0	227.10

(1) Noise measured at 1 m distance with inlet and outlet ports piped, in accordance to ISO 3744.

(2) Value is referred to weight of the machine without electric motor

- Ambient temperature from +5° to +104F.

- Specifications subject to change without notice.

- For proper use, the blower should be equipped with inlet filter and safety valve; other accessories available on request.





SCL K09 / K10  
TS SERIES GOR/GVR RANGE

SN 2164-8 2/2

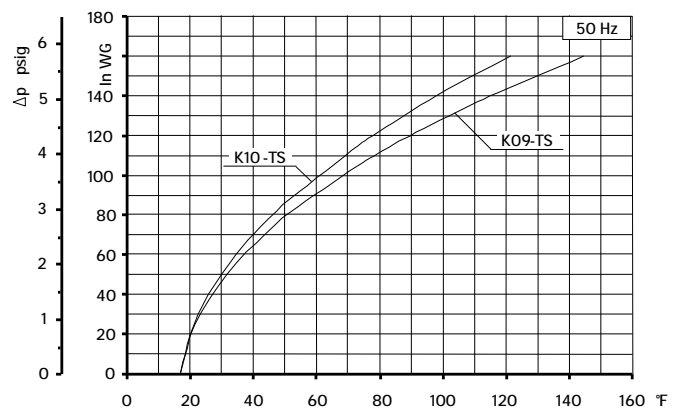
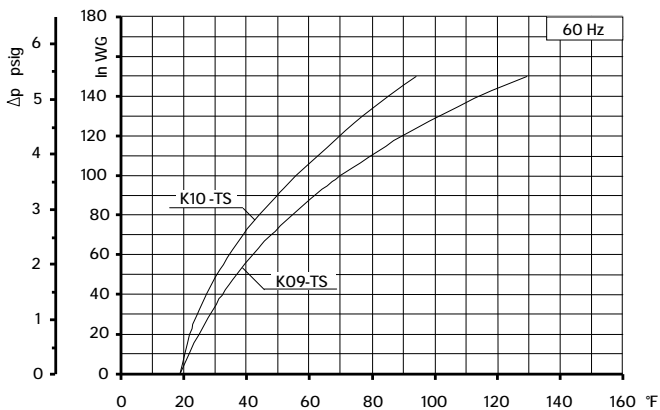
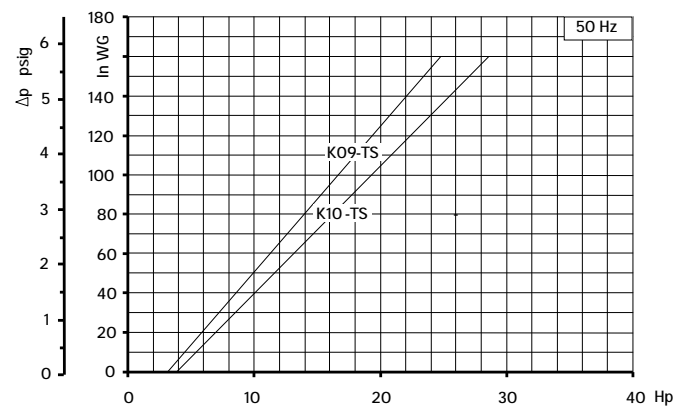
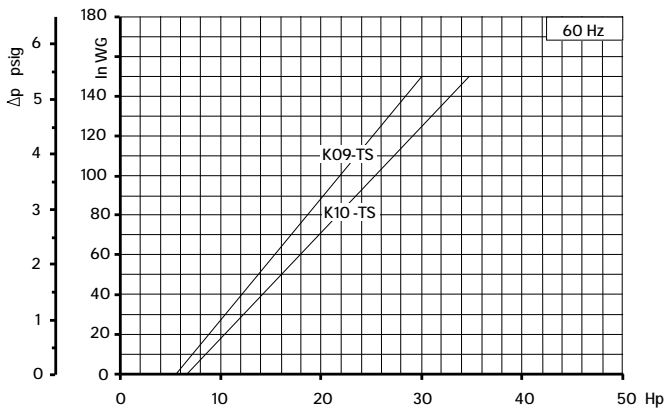
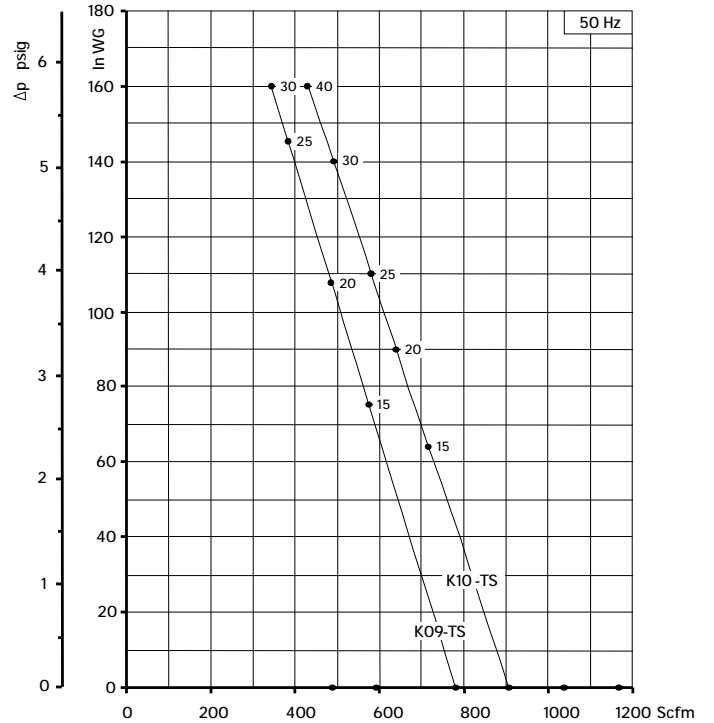
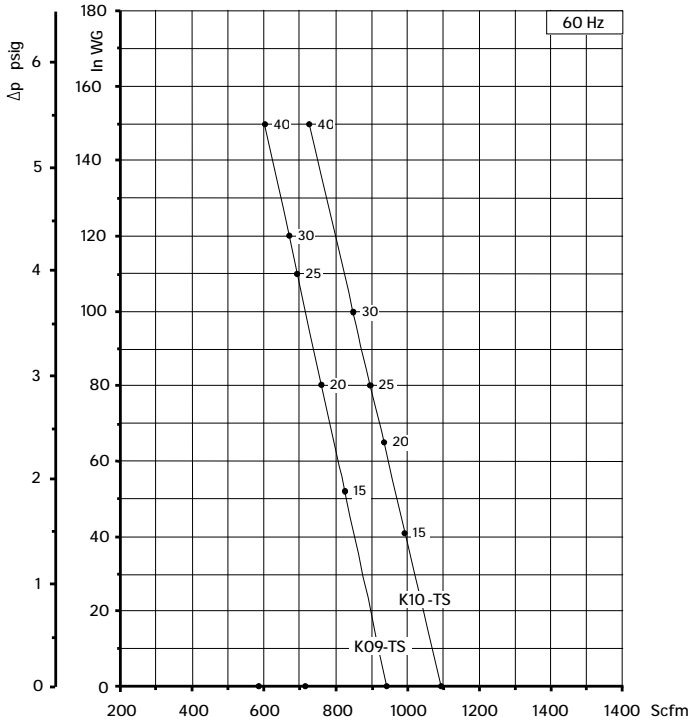

Curves refer to air at 68F temperature and 29.92 In Hg atmospheric pressure (abs) measured at inlet port.  
Values for flow, power consumption and temperature rise: +/-10% tolerance.  
Data subject to change without notice.



SCL K09 / K10  
MD SERIES - GOR/GVR RANGE  
SN 2149-4 1/2

TECHNICAL CHARACTERISTICS

- Aluminium alloy construction
- Smooth operation
- High efficiency impeller
- Maintenance free
- Mountable in any position

OPTIONS

- Special voltages (IEC 38)
- Surface treatments

ACCESSORIES

- Inlet and/or inline filters
- Additional inlet/outlet silencers
- Safety valves
- Flow converting device
- Optional connectors

For dimensions, please refer to drw:

GOR range: SI 1918

GVR range: SI 1919

GOR Range

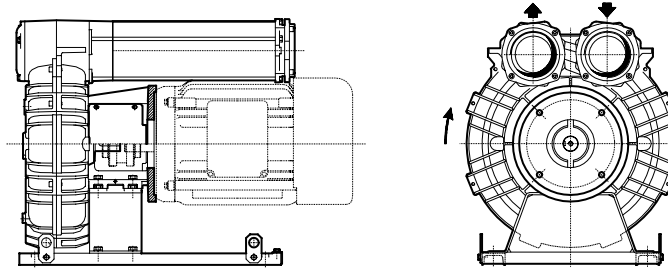

SCL Kxx-MD GOR-C

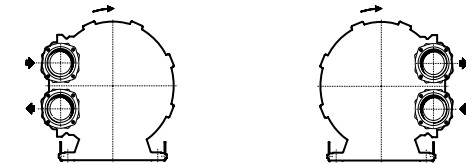

SCL Kxx-MD GOR-A

SCL Kxx-MD GOR-B

GVR Range

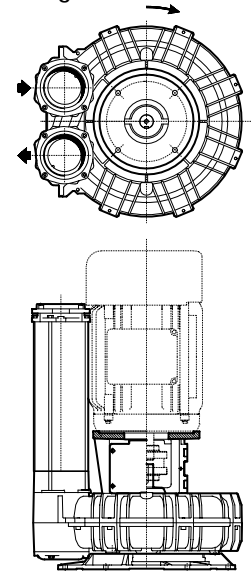

Model	Maximum flow Scfm		Installed power Hp	Size	Maximum differential pressure Δp (In WG)		Noise level Lp dB (A) <sup>(1)</sup>		Weight <sup>(2)</sup> Lbs
	60 Hz 3500 rpm	50 Hz 2900 rpm			60 Hz 3500 rpm	50 Hz 2900 rpm	60 Hz 3500 rpm	50 Hz 2900 rpm	
	K09-MD	221			183	5	NEMA 182-4TC	50	
7 1/2			NEMA 182-4TC	120		143	78.0	76.0	138.50
			NEMA 213-5TC						138.50
			10						NEMA 213-5TC
15	NEMA 213-5TC	280	280	80.5	78.5	138.50			
K10-MD	275	228	7 1/2	NEMA 182-4TC	85	110	79.9	77.9	125.40
				NEMA 213-5TC					152.40
			10	NEMA 213-5TC	140	165	80.3	78.3	152.40
				15	NEMA 213-5TC	245	280	81.4	79.4

(1) Noise measured at 1 m distance with inlet and outlet ports piped, in accordance to ISO 3744.

(2) Value is referred to weight of the machine without electric motor

- For proper use, the blower should be equipped with inlet filter and safety valve; other accessories available on request.
- Ambient temperature from +5° to +104°F.
- Specifications subject to change without notice.



SCL K09 / K10  
MD SERIES - GOR/GVR RANGE

SN 2149-4 2/2

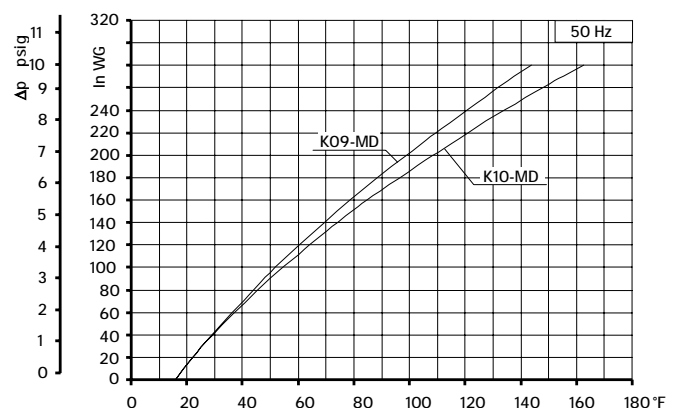
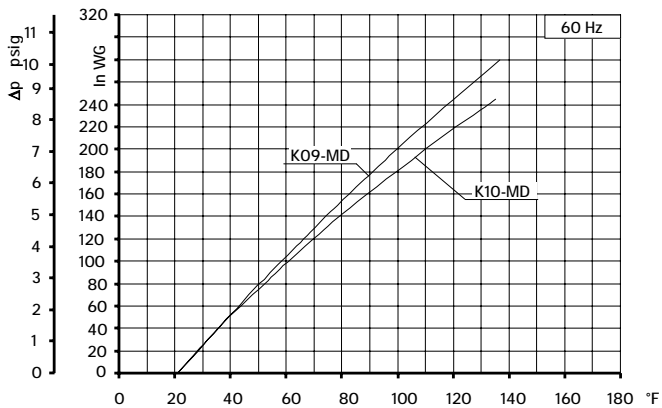
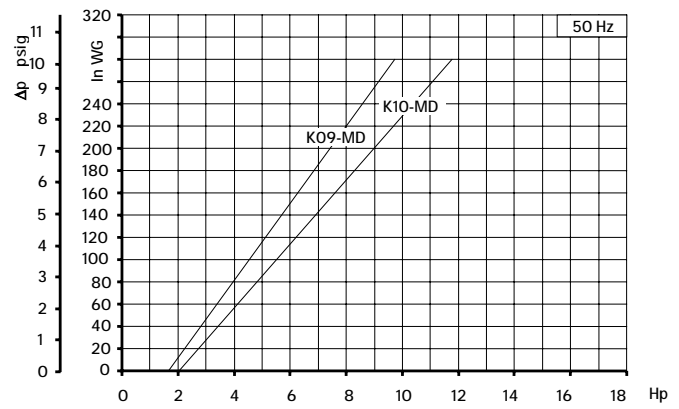
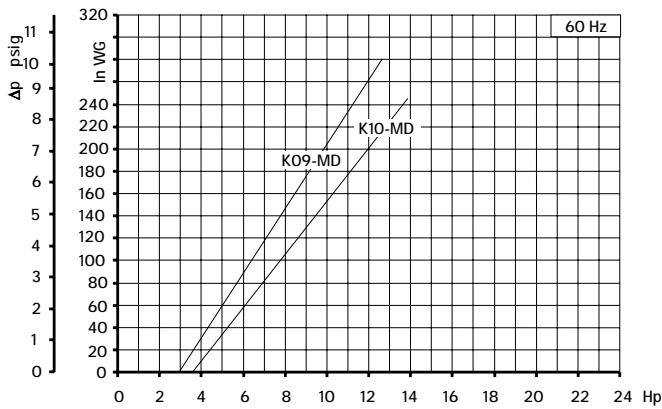
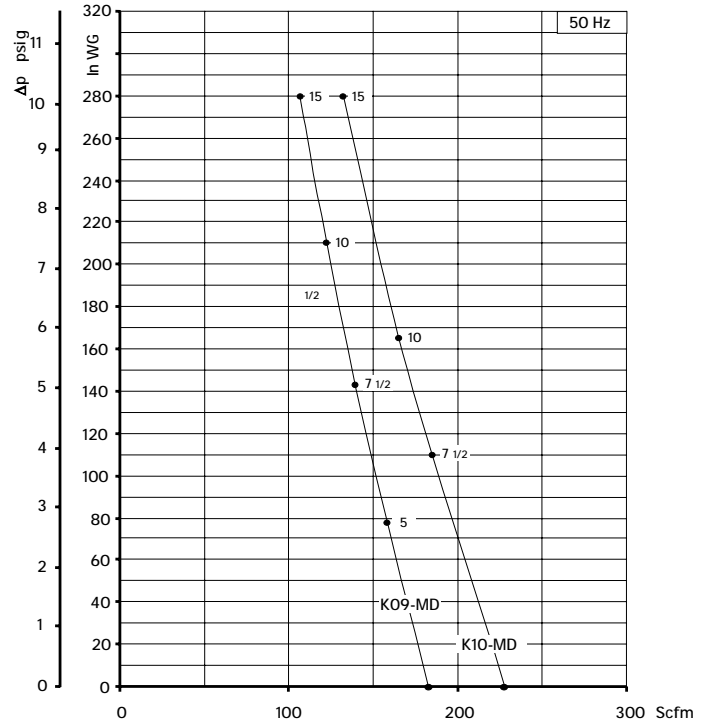
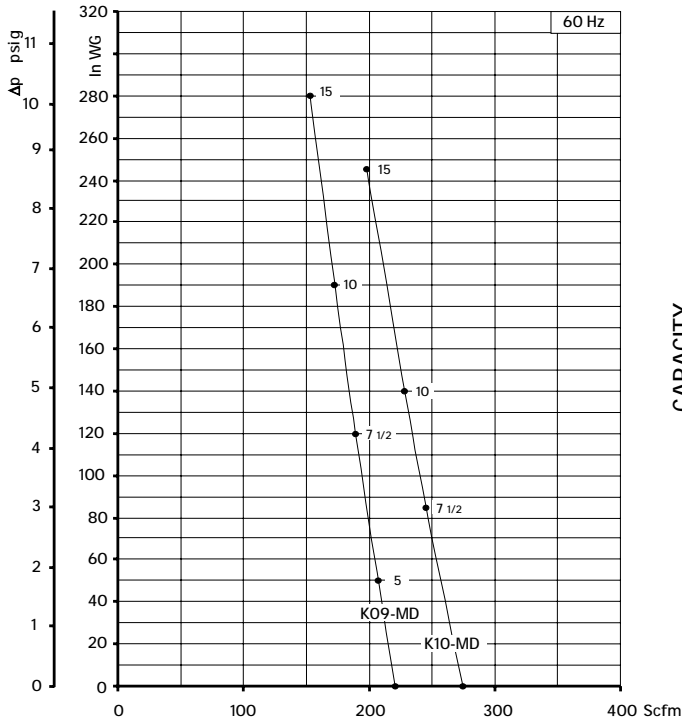

Curves refer to air at 68°F temperature and 29.92 In Hg atmospheric pressure (abs) measured at inlet port.  
 Values for flow, power consumption and temperature rise: +/-10% tolerance.  
 Data subject to change without notice.



**TECHNICAL CHARACTERISTICS**

- Aluminium alloy construction
- Smooth operation
- High efficiency impeller
- Maintenance free
- Mountable in any position
- G1/8" female thread on both suction and discharge silencer port flanges

**OPTIONS**

- Special voltages (IEC 38)
- Surface treatments

**ACCESSORIES**

- Inlet and/or inline filters
- Additional inlet/outlet silencers
- Safety valves
- Flow converting device
- Optional connectors

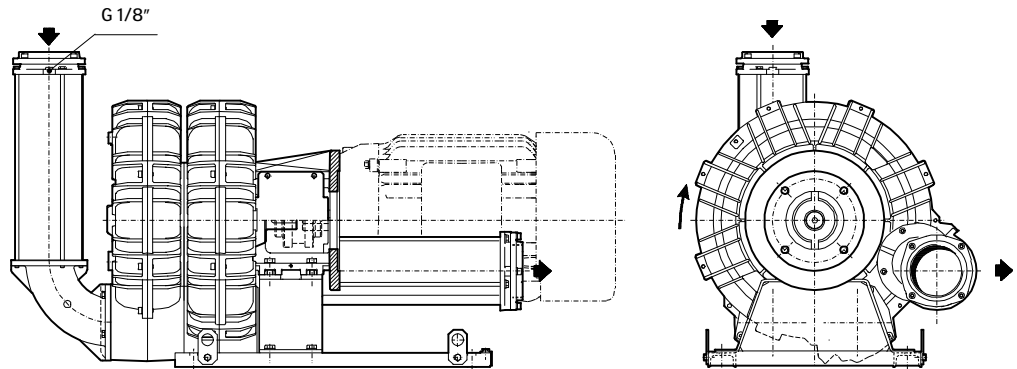

For dimensions, please refer to drw: SI 1971

Model	Maximum flow Scfm		Installed power Hp	Size	Maximum differential pressure $\Delta p$ (In WG)		Noise level Lp dB (A) <sup>(1)</sup>		Weight <sup>(2)</sup> Lbs
	60 Hz 3500 rpm	50 Hz 2900 rpm			60 Hz 3500 rpm	50 Hz 2900 rpm	60 Hz 3500 rpm	50 Hz 2900 rpm	
	K09-TD	467			387	15	NEMA 213-5TC NEMA 254-6TC	105	
20			NEMA 254-6TC	160		225	83.0	81.0	201.70
25			NEMA 284-6TSC	220		240	83.3	81.3	198.40
30			NEMA 284-6TSC	240			83.6	81.6	198.40
K10-TD	571	473	15	NEMA 213-5TC NEMA 254-6TC	85	130	86.6	84.6	202.80 209.50
			20	NEMA 254-6TC	130	180	86.9	84.9	209.50
			25	NEMA 284-6TSC	180	240	87.2	85.2	205.00
			30	NEMA 284-6TSC	200		87.5		205.00
			40	NEMA 324-6TSC	240		87.8		220.50

(1) Noise measured at 1 m distance with inlet and outlet ports piped, in accordance to ISO 3744.

(2) Value is referred to weight of the machine without electric motor

- For proper use, the blower should be equipped with inlet filter and safety valve; other accessories available on request.
- Ambient temperature from +5° to +104°F.
- Specifications subject to change without notice.



SCL K09 / K10  
TD SERIES - GOR RANGE

SN 2179-6 2/2

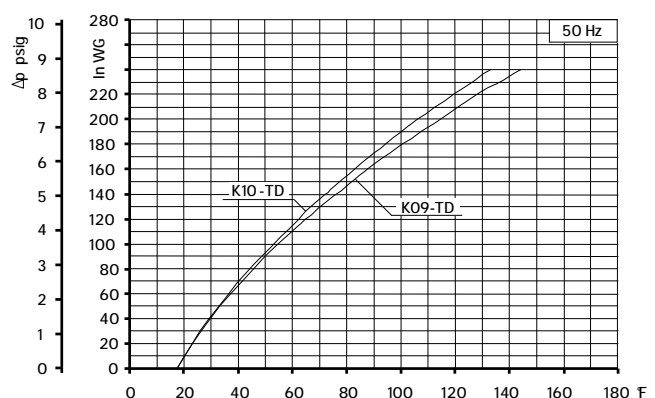
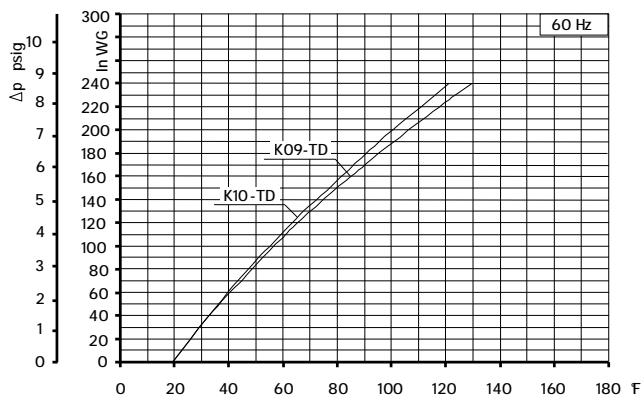
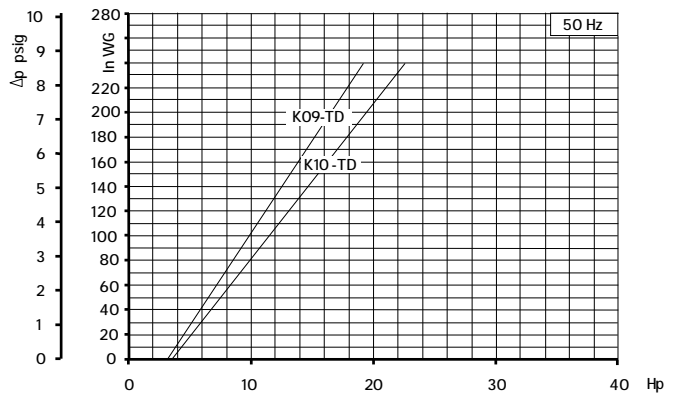
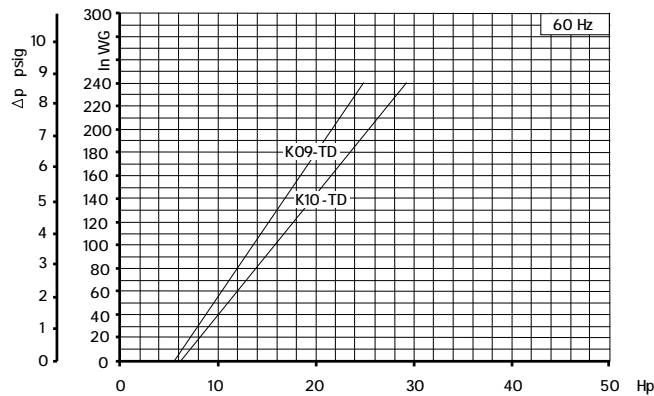
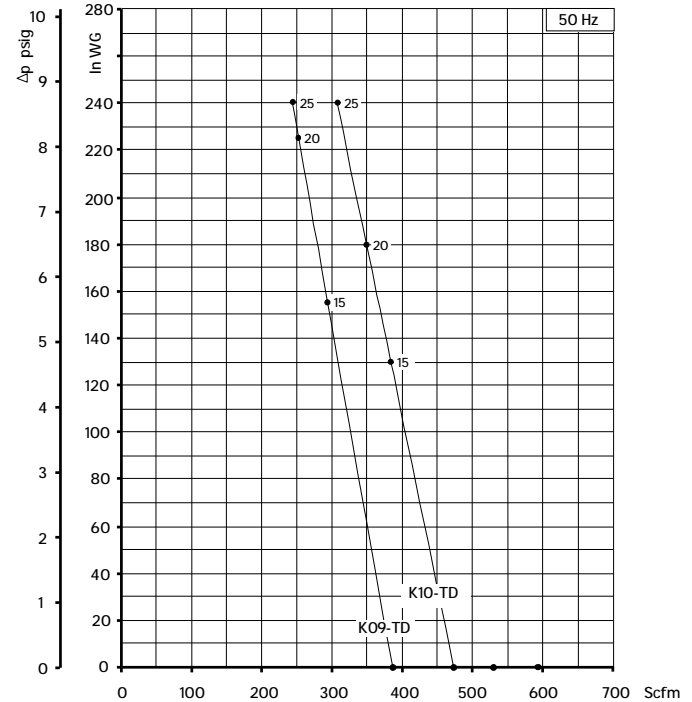
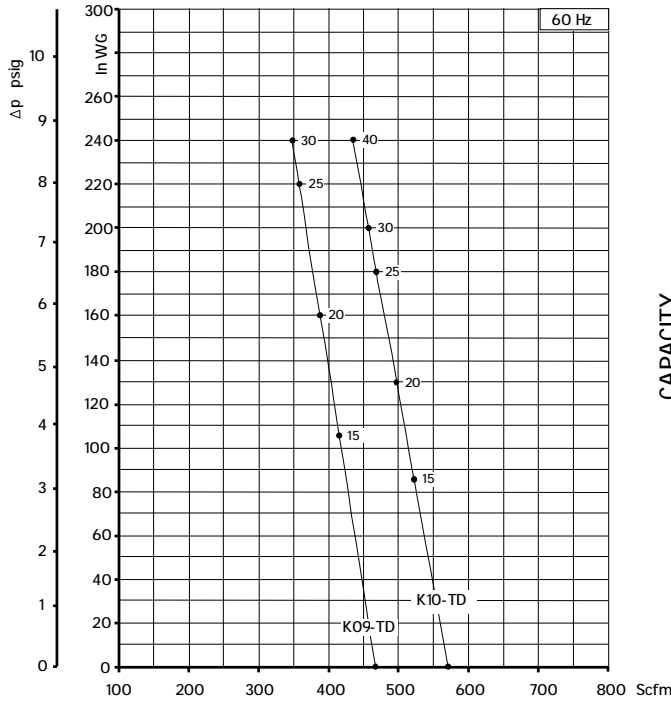

Curves refer to air at 68°F temperature and 29.92 In Hg atmospheric pressure (abs) measured at inlet port.  
Values for flow, power consumption and temperature rise +/-10% tolerance.  
Data subject to change without notice.



**TECHNICAL CHARACTERISTICS**

- Aluminium alloy construction
- Smooth operation
- High efficiency impeller
- Maintenance free
- Mountable in any position
- Recognized TEFC - cURus motor

**OPTIONS**

- Special voltages (IEC 38)
- Surface treatments

**ACCESSORIES**

- Inlet and/or inline filters
- Additional inlet/outlet silencers
- Safety valves
- Flow converting device
- Optional connectors

Dimensions in inches.

Dimension for reference only.

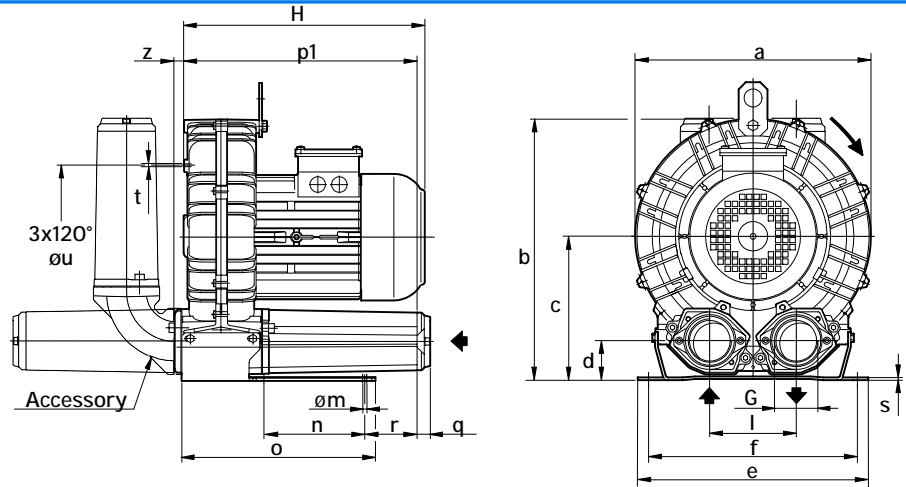

Model	a	b	c	d	e	f	G	l	m	n	o	p1	q	r	s	t	u	z
K03-MS	9.49	10.55	5.79	1.69	9.06	8.07	1" ¼ NPT	3.39	0.39	3.27	5.59	8.07	0.71	2.95	0.16	M6	5.51	0.47
K04-MS	11.22	12.40	6.77	1.93	10.04	8.86	1"½ NPT	4.02	0.47	3.74	6.73	8.74	0.71	2.76	0.16	M6	6.89	0.71
K05-MS	12.87	14.37	7.87	2.13	12.80	10.24	2" NPT	4.72	0.59	4.53	10.43	12.60	0.71	3.86	0.16	M8	7.87	0.75
K06-MS	14.80	15.47	8.07	2.13	12.80	11.42	2" NPT	4.92	0.59	5.51	10.71	13.15	0.71	3.35	0.16	M8	9.45	0.75

Model	Maximum flow cfm		Installed power Hp		Maximum differential pressure Δp (In Hg)		Noise level Lp dB (A) (1)		Overall dimensions H Inches	Weight Lbs
	60 Hz 3500 rpm	50 Hz 2900 rpm	60 Hz 3500 rpm	50 Hz 2900 rpm	60 Hz 3500 rpm	50 Hz 2900 rpm	60 Hz 3500 rpm	50 Hz 2900 rpm		
K03-MS	52	43	3/4	3/4	4.7	3.7	61.0	59.0	10.43	24.3
			1	1	5.9	4.9	61.3	59.3	12.0	32.0
K04-MS	98	81	1 ½	1 ½	4.3	5.9	63.8	61.8	11.65	40.3
			2	2	6.3	6.6	64.0	62.0	14.20	56.8
			3	-	7.4	-	64.2	-	14.20	58.4
K05-MS	156	129	2	2	3.8	5.1	69.5	67.5	13.20	56.7
			3	3	6.6	7.1	69.8	67.8	13.20	60.6
			4	-	8.1	-	70.1	-	14.40	77.2
K06-MS	216	179	3	3	3.7	4.8	72.0	70.0	13.8	69.0
			4	4	5.2	7.0	72.3	70.3	14.17	82.5
			5 ½	5 ½	8.1	8.1	72.6	70.6	15.5	85.3
			6 1/5	-	8.9	-	72.9	-	16.3	95.5

(1) Noise measured at 1 m distance with inlet and outlet ports piped, in accordance to ISO 3744.

- For proper use, the blower should be equipped with inlet filter and safety valve; other accessories available on request.
- Ambient temperature from +5° to +104°F.
- Specifications subject to change without notice.



SCL K03 / K04 / K05 / K06  
MS SERIES  
SN 1879-14B 2/2

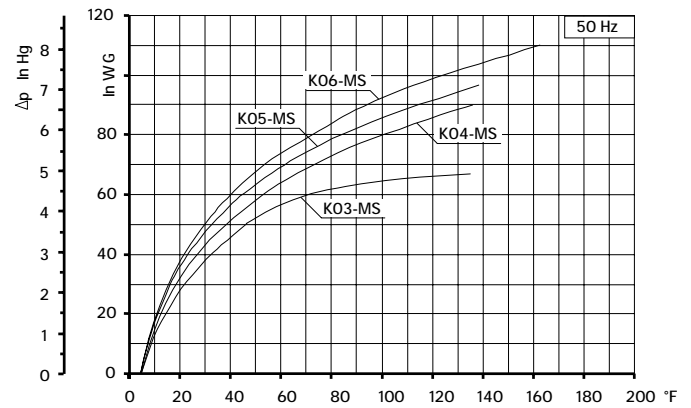
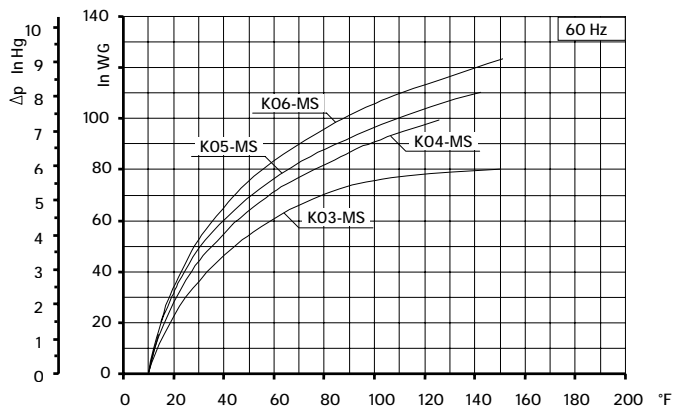
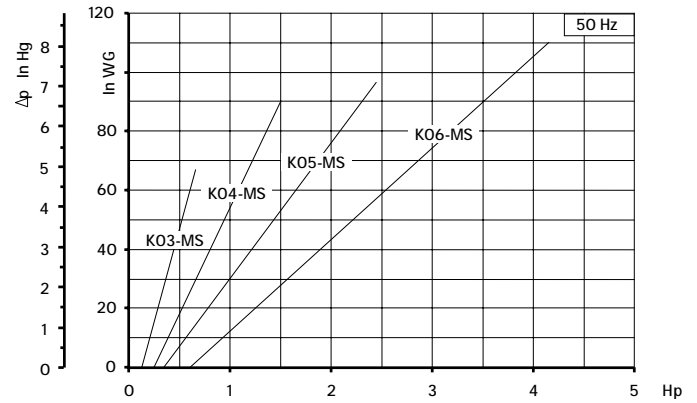
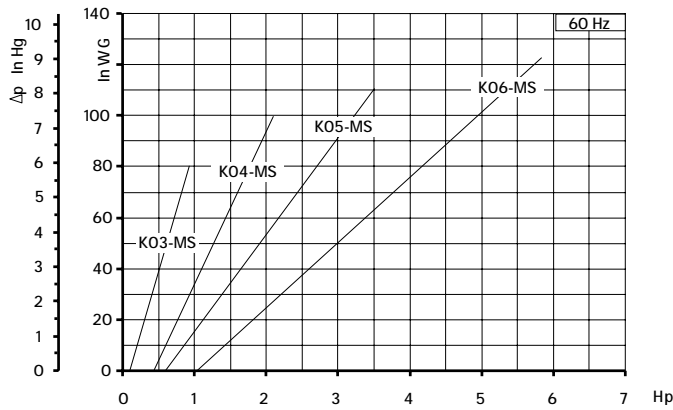
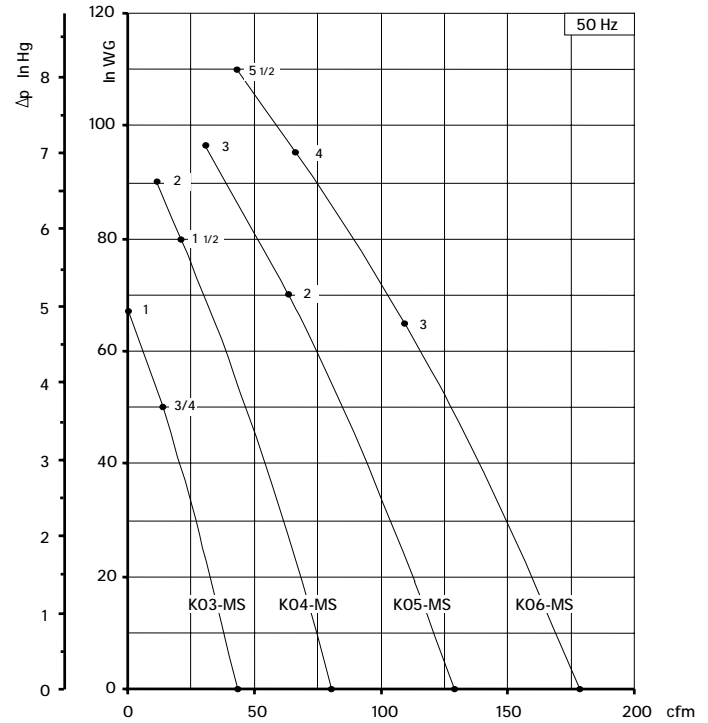
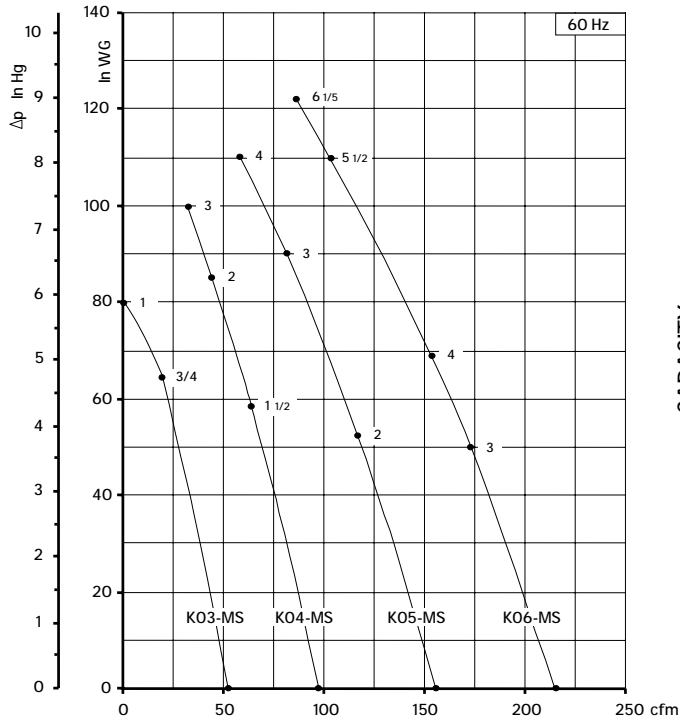

Curves refer to air at 68° F temperature, measured at inlet port and 29.92 In Hg atmospheric back pressure (abs).  
Values for flow, power consumption and temperature rise: +/-10% tolerance.  
Data subject to change without notice.



**TECHNICAL CHARACTERISTICS**

- Aluminium alloy construction
- Smooth operation
- High efficiency impeller
- Maintenance free
- Mountable in any position
- Recognized TEFC - cURus motor

**OPTIONS**

- Special voltages (IEC 38)
- Surface treatments

**ACCESSORIES**

- Inlet and/or inline filters
- Additional inlet/outlet silencers
- Safety valves
- Flow converting device
- Optional connectors

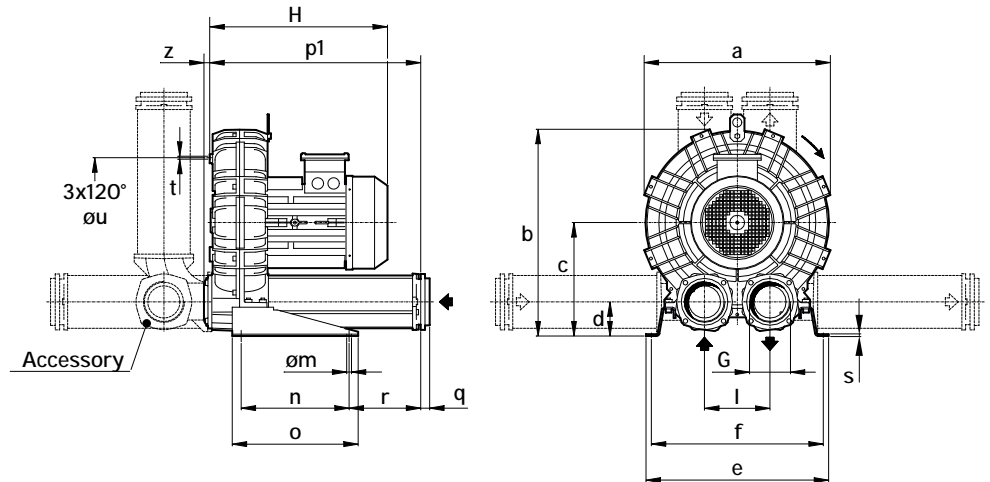

Dimensions in inches.  
Dimension for reference only.

Model	a	b	c	d	e	f	G	l	m	n	o	p1	q	r	s	t	u	z
K09-MS	19.37	22.09	12.40	3.78	20.00	18.82	4" NPT	7.17	0.51	11.81	13.78	23.07	0.98	7.83	0.20	M8	14.17	0.63
K10-MS	20.31	22.56	12.40	3.78	20.00	18.82	4" NPT	7.17	0.51	11.81	13.78	23.07	0.98	7.83	0.20	M8	14.17	0.63

Model	Maximum flow cfm		Installed power Hp		Maximum differential pressure $\Delta p$ (In Hg)		Noise level Lp dB (A) (1)		Overall dimensions H Inches	Weight Lbs
	60 Hz 3500 rpm	50 Hz 2900 rpm	60 Hz 3500 rpm	50 Hz 2900 rpm	60 Hz 3500 rpm	50 Hz 2900 rpm	60 Hz 3500 rpm	50 Hz 2900 rpm		
K09-MS	471	390	7 1/2	7 1/2	3.7	4.6	79.3	77.3	18.8	186.3
			10	10	5.9	7.0	79.6	77.6	19.5	245.0
			15	15	9.6	10.4	80.1	78.1	22.0	212.0
K10-MS	556	460	7 1/2	7 1/2	2.4	3.8	79.4	77.4	18.8	189.6
			10	10	4.4	5.9	79.7	77.7	19.5	202.0
			15	15	8.1	9.9	80.2	78.2	19.6	215.0
			20	-	9.6	-	80.5	-	22.0	248.0

(1) Noise measured at 1 m distance with inlet and outlet ports piped, in accordance to ISO 3744.

- For proper use, the blower should be equipped with inlet filter and safety valve; other accessories available on request.
- Ambient temperature from +5° to +104°F.
- Specifications subject to change without notice.





SCL K09 / K10  
MS SERIES

SN 1810-21 2/2

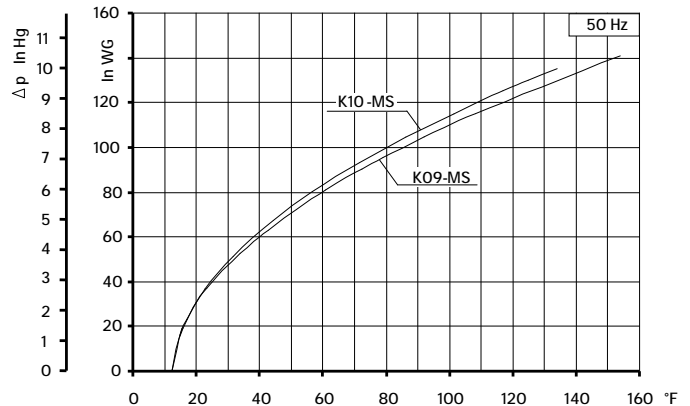
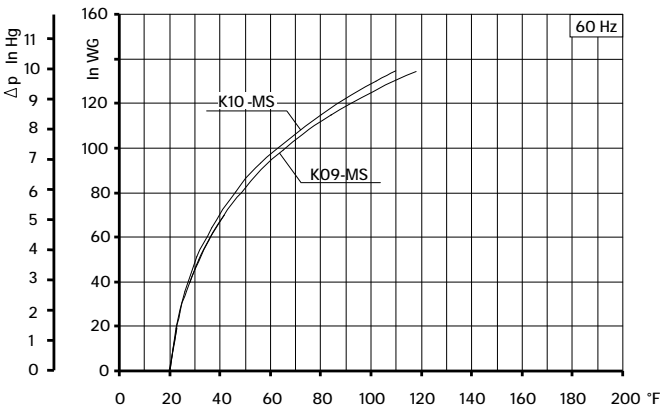
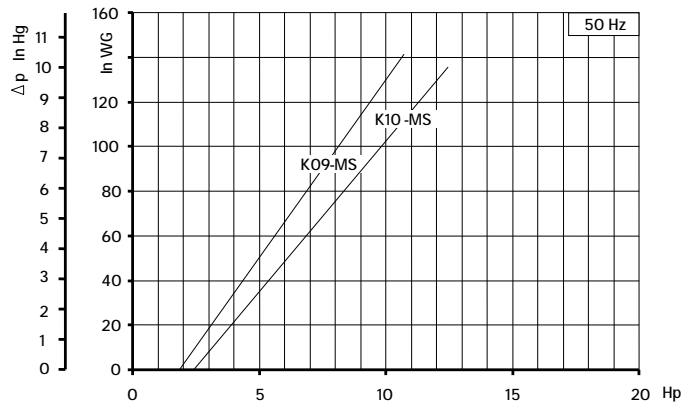
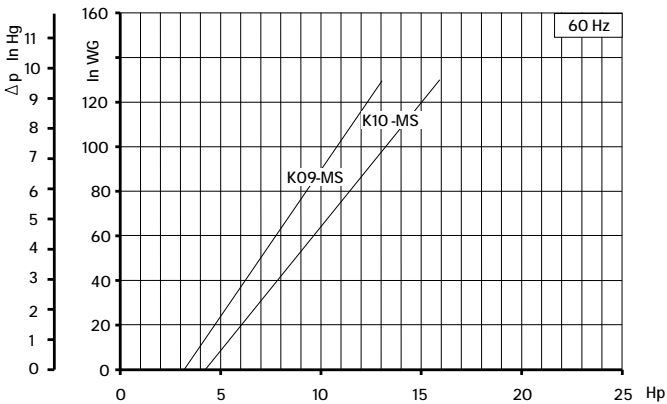
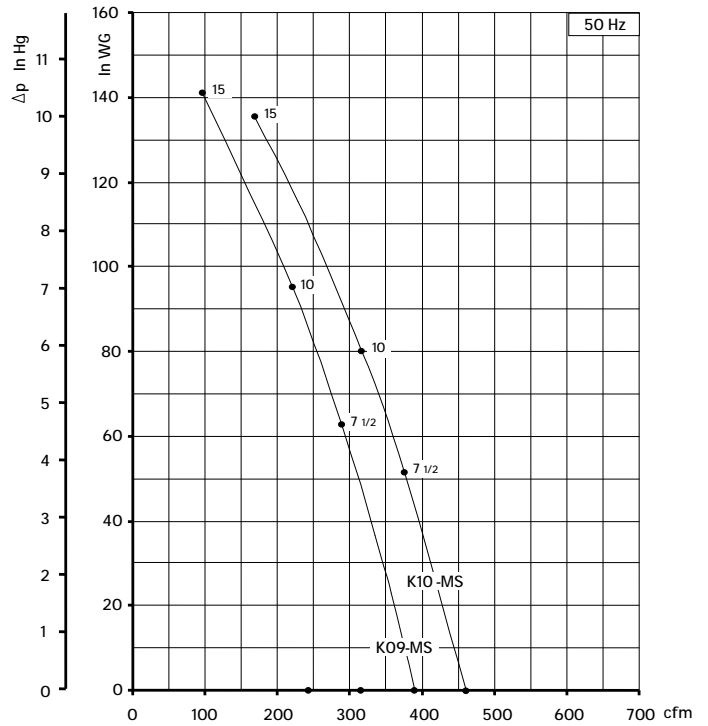
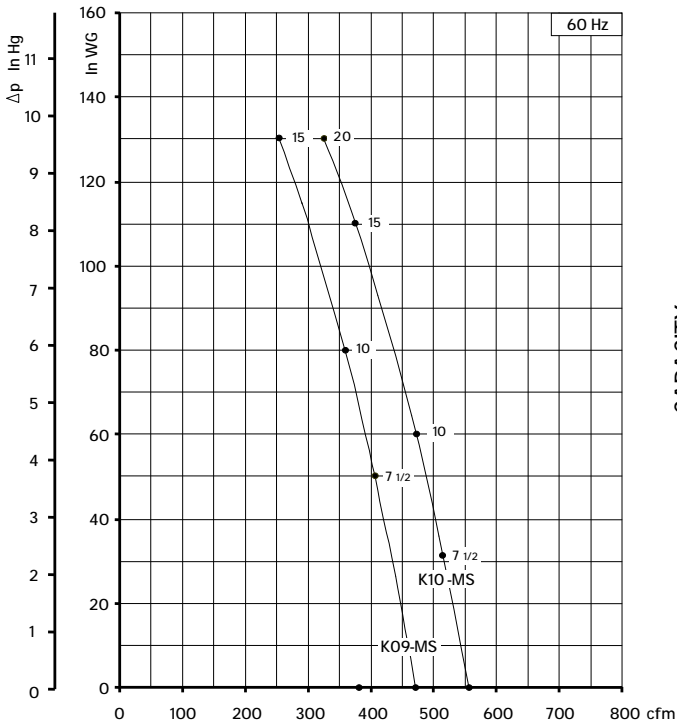

Curves refer to air at 68° F temperature, measured at inlet port and 29.92 In Hg atmospheric backpressure (abs).  
 Values for flow, power consumption and temperature rise: +/-10% tolerance.  
 Data subject to change without notice.



**TECHNICAL CHARACTERISTICS**

- Aluminium alloy construction
- Smooth operation
- High efficiency impeller
- Maintenance free
- Mountable in any position
- Recognized TEFC-cURus motor

**OPTIONS**

- Special voltages (IEC 38)
- Surface treatments

**ACCESSORIES**

- Inlet and/or inline filters
- Additional inlet/outlet silencers
- Safety valves
- Flow converting device
- Optional connectors

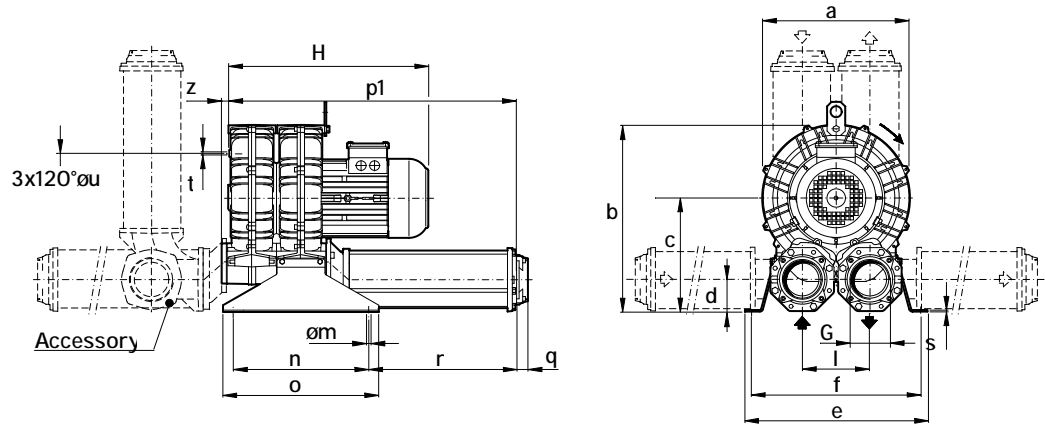

Dimensions in inches.  
Dimension for reference only.

Model	a	b	c	d	e	f	G	l	m	n	o	pl	q	r	s	t	u	z
K05-TS	12.87	16.61	10.16	3.03	15.91	14.72	3" NPT	5.91	0.51	11.81	13.58	24.96	0.98	12.91	0.16	M8	7.87	0.75
K06-TS	14.80	17.72	10.31	2.95	15.91	14.72	3" NPT	6.10	0.51	11.81	13.58	26.06	0.98	13.19	0.16	M8	9.45	0.75

Model	Maximum flow cfm		Installed power Hp		Maximum differential pressure $\Delta p$ (In Hg)		Noise level Lp dB (A) (1)		Overall dimensions H Inches	Weight Lbs
	60 Hz 3500 rpm	50 Hz 2900 rpm	60 Hz 3500 rpm	50 Hz 2900 rpm	60 Hz 3500 rpm	50 Hz 2900 rpm	60 Hz 3500 rpm	50 Hz 2900 rpm		
K05-TS	290	241	5 ½	5 ½	5.3	6.6	75.1	73.1	19.5	109.0
K06-TS	400	331	10	10	6.3	7.4	77.4	75.4	24.5	181.0

(1) Noise measured at 1 m distance with inlet and outlet ports piped, in accordance to ISO 3744.

- For proper use, the blower should be equipped with inlet filter and safety valve; other accessories available on request.
- Ambient temperature from +5° to +104°F.
- Specifications subject to change without notice.



SCL K05 / K06  
TS SERIES  
SN 1926-9B 2/2

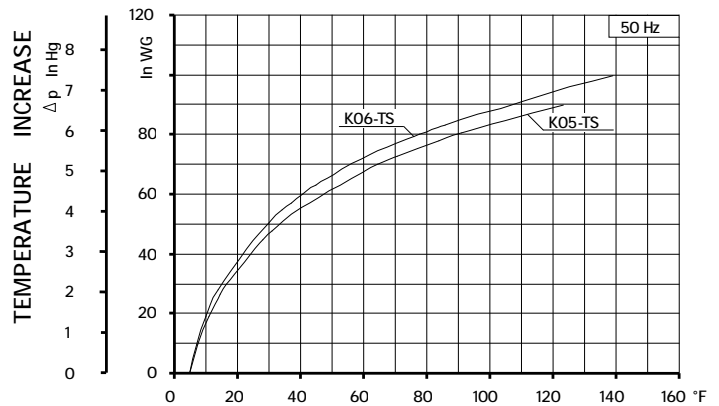
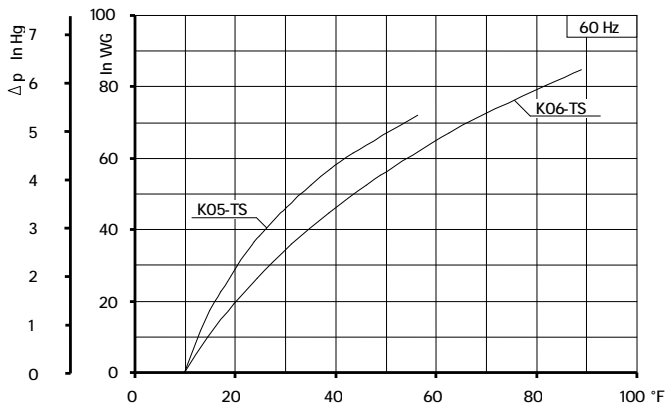
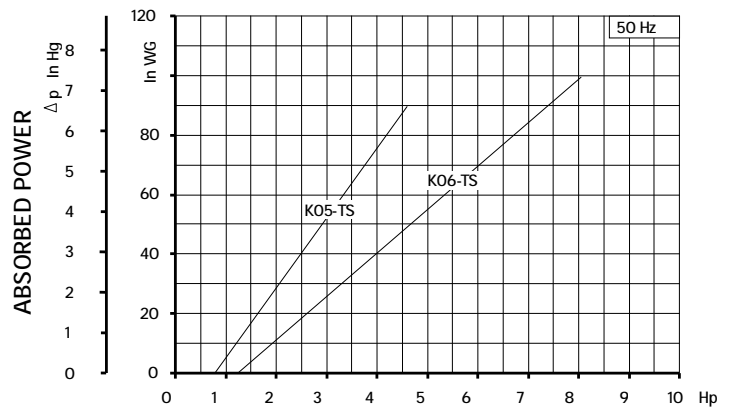
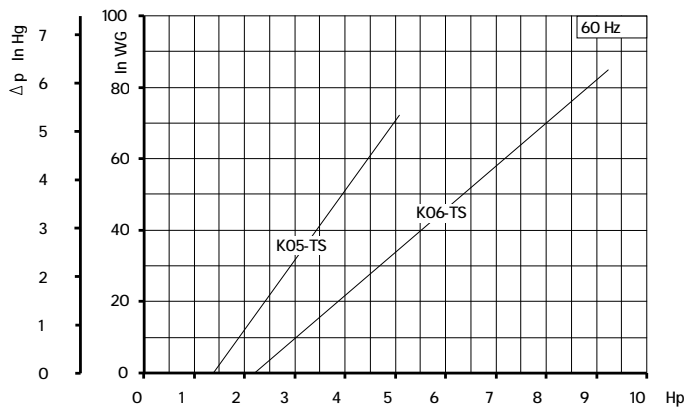
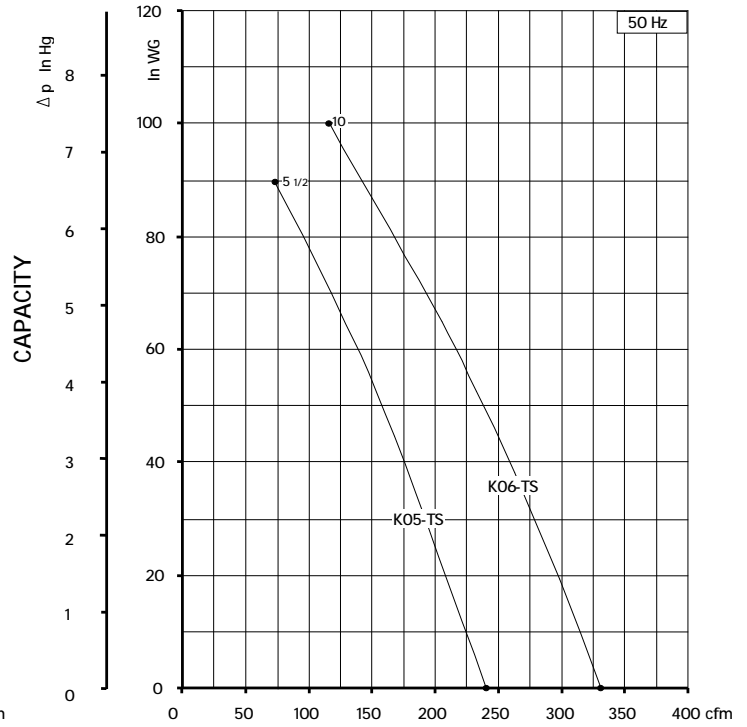
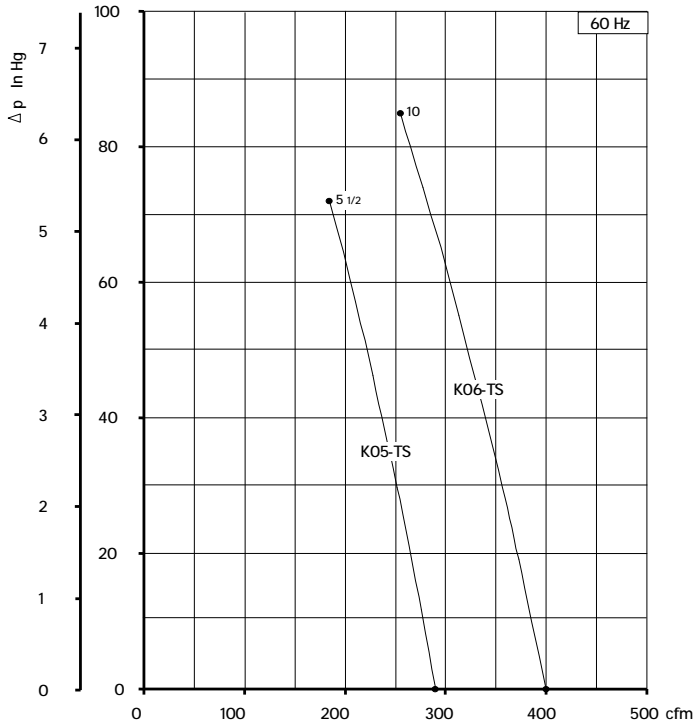

Curves refer to air at 68° F temperature, measured at inlet port and 29.92 In Hg atmospheric backpressure (abs).  
 Values for flow, power consumption and temperature rise: +/- 10% tolerance.  
 Data subject to change without notice.



**TECHNICAL CHARACTERISTICS**

- Aluminium alloy construction
- Smooth operation
- High efficiency impeller
- Maintenance free
- Mountable in any position
- Recognized TEFC-cURus motor
- G1/8" female thread on both suction and discharge silencer port flanges

**OPTIONS**

- Special voltages (IEC 38)
- Surface treatments

**ACCESSORIES**

- Inlet and/or inline filters
- Additional inlet/outlet silencers
- Safety valves
- Flow converting device
- Optional connectors

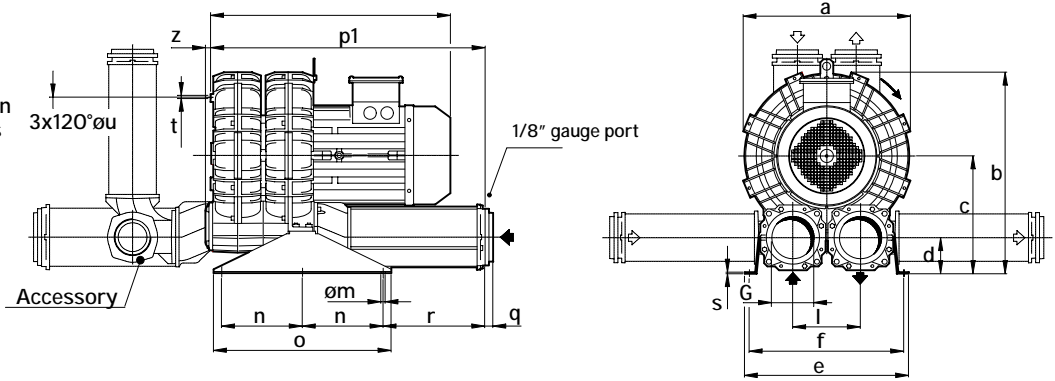

Dimensions in inches.  
Dimension for reference only.

Model	a	b	c	d	e	f	G	l	m	n	o	p1	q	r	s	t	u	z
K09-TS	19.37	24.02	14.37	4.41	20.08	18.82	5" NPT	8.27	0.51	9.84	21.65	33.46	1.38	12.40	0.20	M8	14.17	0.63
K10-TS	20.31	24.53	14.37	4.41	20.08	18.82	5" NPT	8.27	0.51	9.84	21.65	33.46	1.38	12.40	0.20	M8	14.17	0.63

Model	Maximum flow cfm		Installed power Hp		Maximum differential pressure Δp (in Hg)		Noise level Lp dB (A) (1)		Overall dimensions H Inches	Weight Lbs
	60 Hz 3500 rpm	50 Hz 2900 rpm	60 Hz 3500 rpm	50 Hz 2900 rpm	60 Hz 3500 rpm	50 Hz 2900 rpm	60 Hz 3500 rpm	50 Hz 2900 rpm		
	K09-TS	941	780	20	20	5.9	7.4	85.0		
			25	25	8.1	8.8	87.0	85.0	31.0	432.0
K10-TS	1093	906	20	20	4.4	5.9	88.1	86.1	31.0	429.0
			25	25	5.9	7.4	88.4	86.4	31.0	439.0

(1) Noise measured at 1 m distance with inlet and outlet ports piped, in accordance to ISO 3744.

- For proper use, the blower should be equipped with inlet filter and safety valve; other accessories available on request.
- Ambient temperature from +5° to +104°F.
- Specifications subject to change without notice.

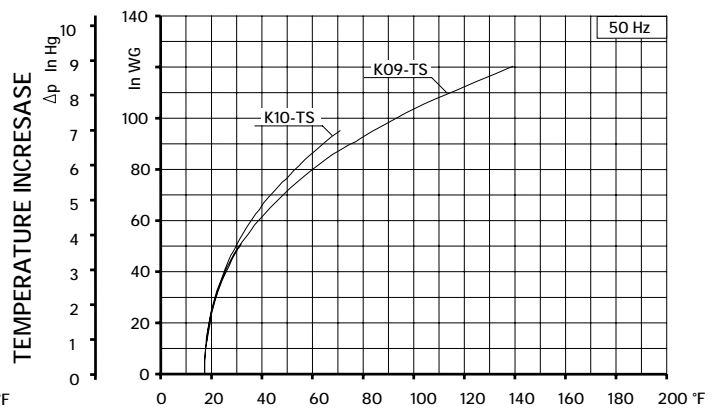
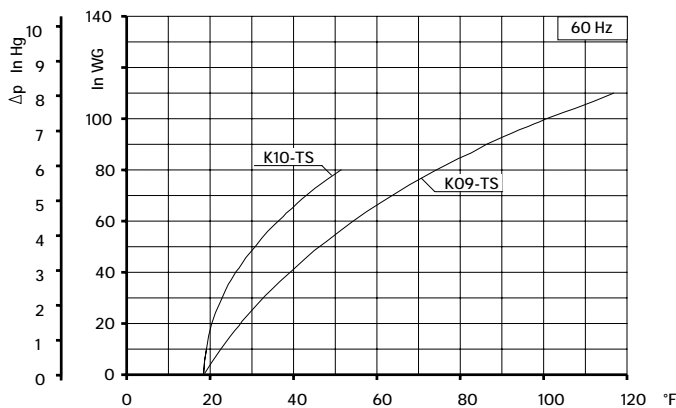
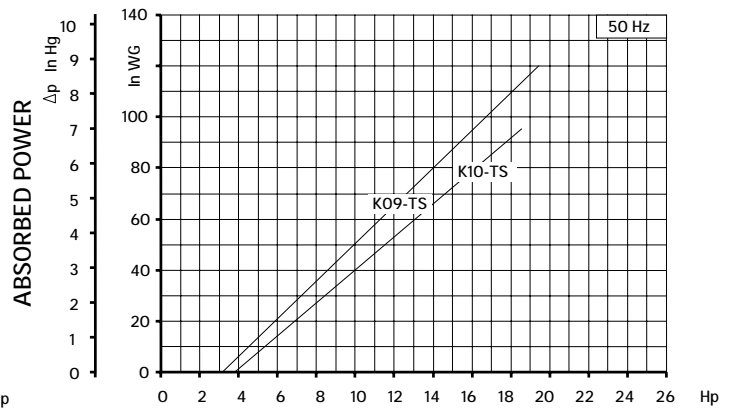
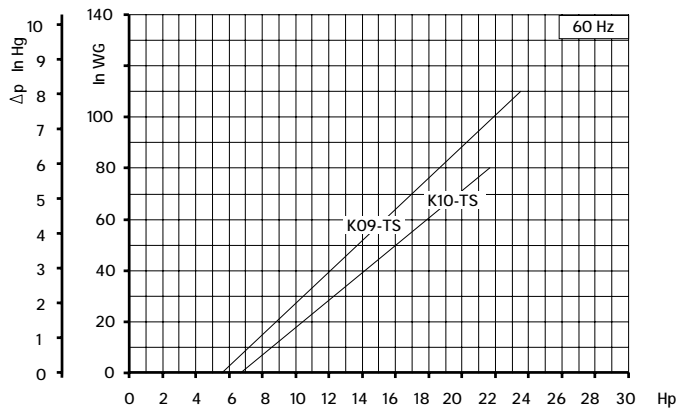
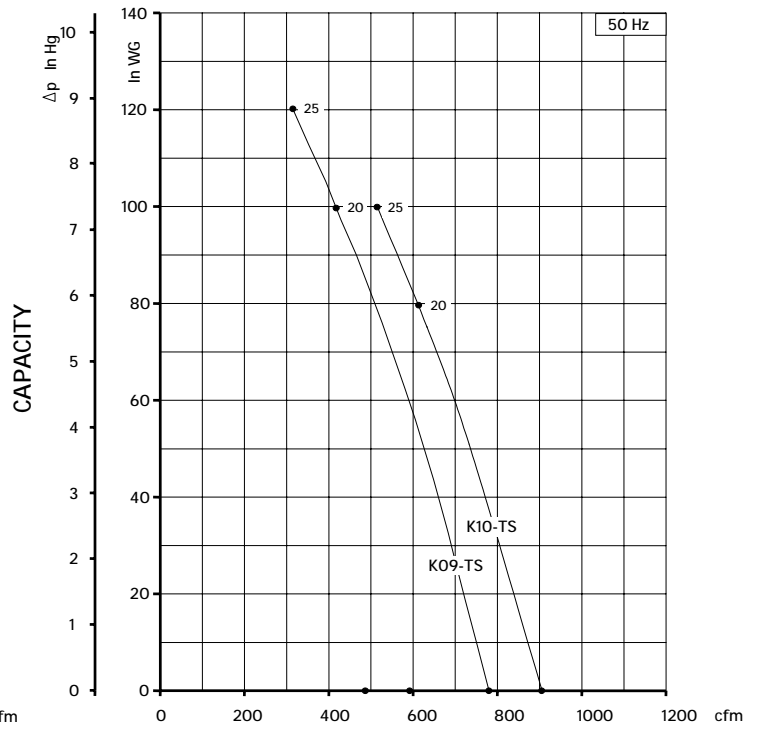
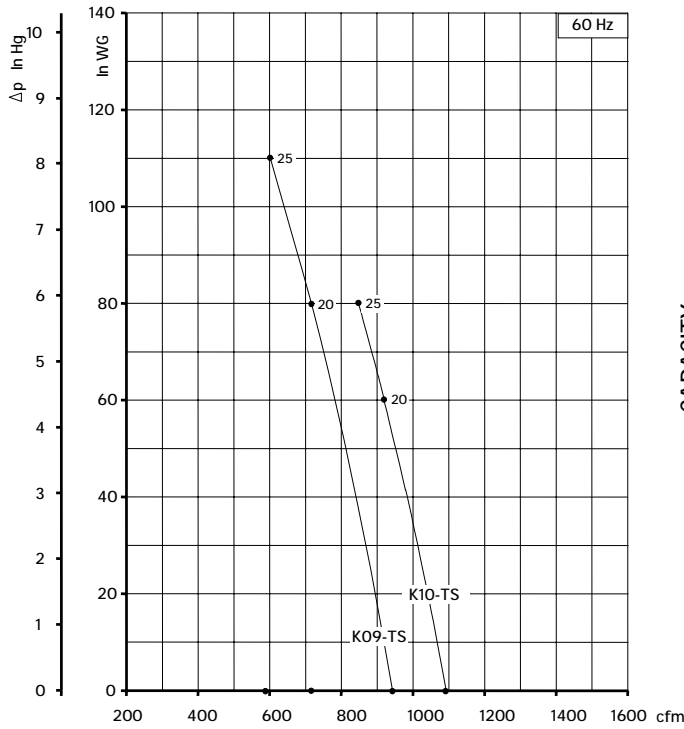

Curves refer to air at 68° F temperature, measured at inlet port and 29.92 In Hg atmospheric backpressure (abs).  
 Values for flow, power consumption and temperature rise: +/-10% tolerance.  
 Data subject to change without notice.



**TECHNICAL CHARACTERISTICS**

- Aluminium alloy construction
- Smooth operation
- High efficiency impeller
- Maintenance free
- Mountable in any position
- Recognized TEFC - cURus motor

**OPTIONS**

- Special voltages (IEC 38)
- Surface treatments

**ACCESSORIES**

- Inlet and/or inline filters
- Additional inlet/outlet silencers
- Safety valves
- Flow converting device
- Optional connectors

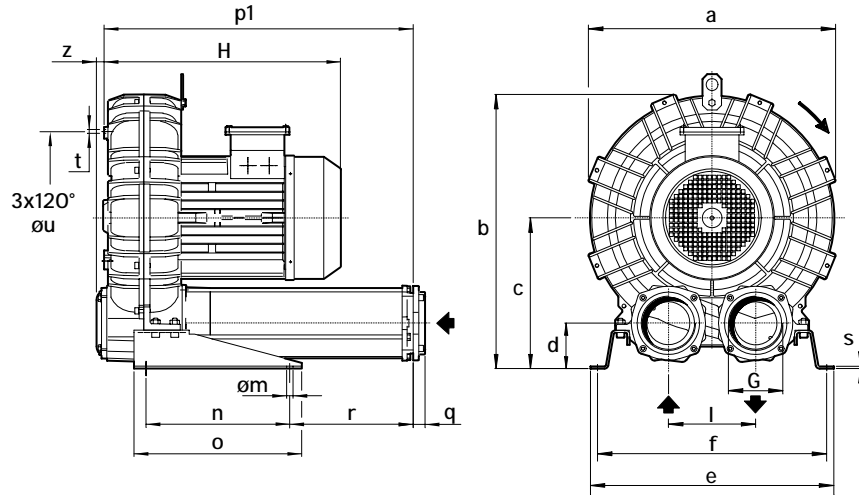

Dimensions in inches.  
Dimension for reference only.

Model	a	b	c	d	e	f	G	l	m	n	o	p1	q	r	s	t	u	z
K09-MD	19.37	22.09	12.40	3.78	20.00	18.82	4" NPT	7.17	0.51	11.81	13.78	25.35	0.98	10.12	0.20	M8	14.17	0.63
K10-MD	20.31	22.56	12.40	3.78	20.00	18.82	4" NPT	7.17	0.51	11.81	13.78	25.35	0.98	10.12	0.20	M8	14.17	0.63

Model	Maximum flow cfm		Installed power Hp		Maximum differential pressure Δp (In Hg)		Noise level Lp dB (A) <sup>(1)</sup>		Overall dimensions H Inches	Weight Lbs
	60 Hz 3500 rpm	50 Hz 2900 rpm	60 Hz 3500 rpm	50 Hz 2900 rpm	60 Hz 3500 rpm	50 Hz 2900 rpm	60 Hz 3500 rpm	50 Hz 2900 rpm		
K09-MD	221	183	10	10	14.0	11.8	79.5	77.5	19.50	210
K10-MD	275	228	10	10	9.6	12.6	80.3	78.3	19.50	214
			15	15	12.6	-	81.4	79.4	19.50	228

(1) Noise measured at 1 m distance with inlet and outlet ports piped, in accordance to ISO 3744.

- For proper use, the blower should be equipped with inlet filter and safety valve; other accessories available on request.
- Ambient temperature from +5° to +104°F.
- Specifications subject to change without notice.

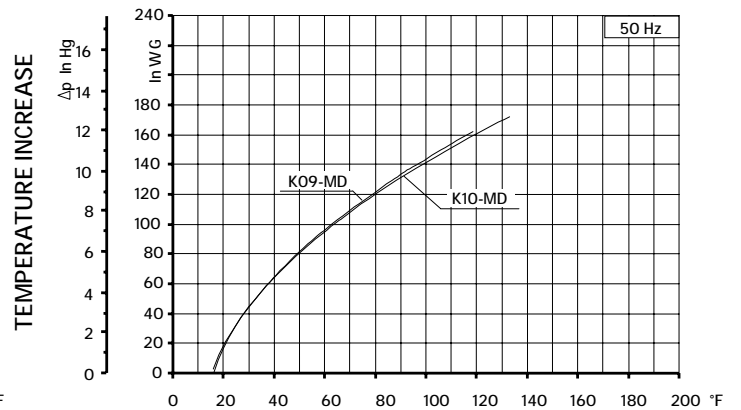
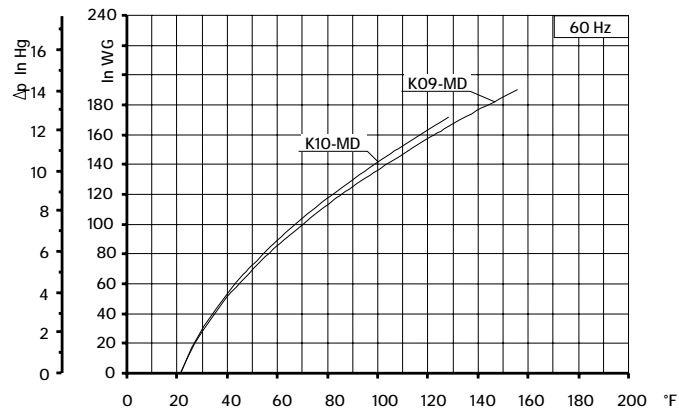
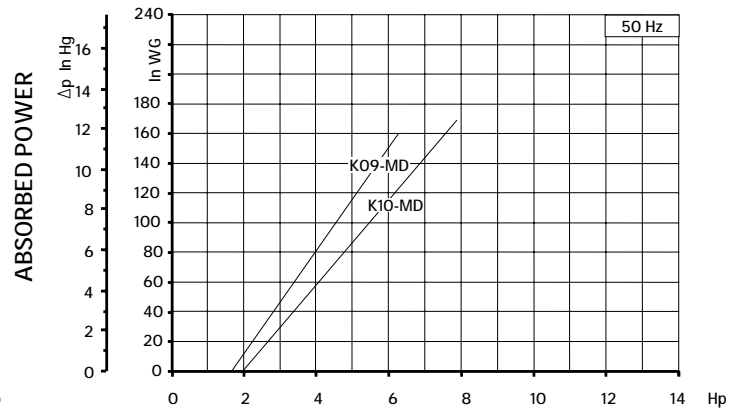
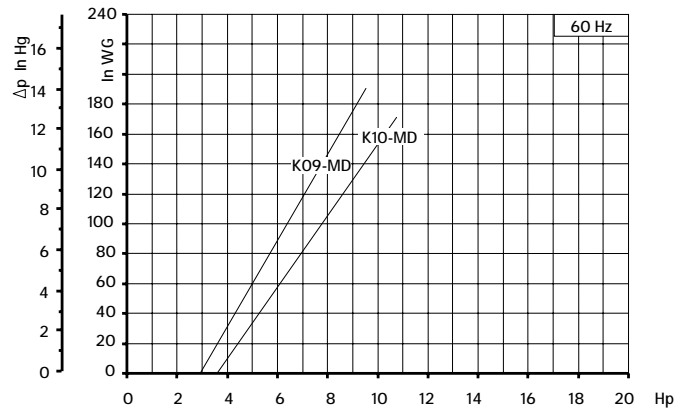
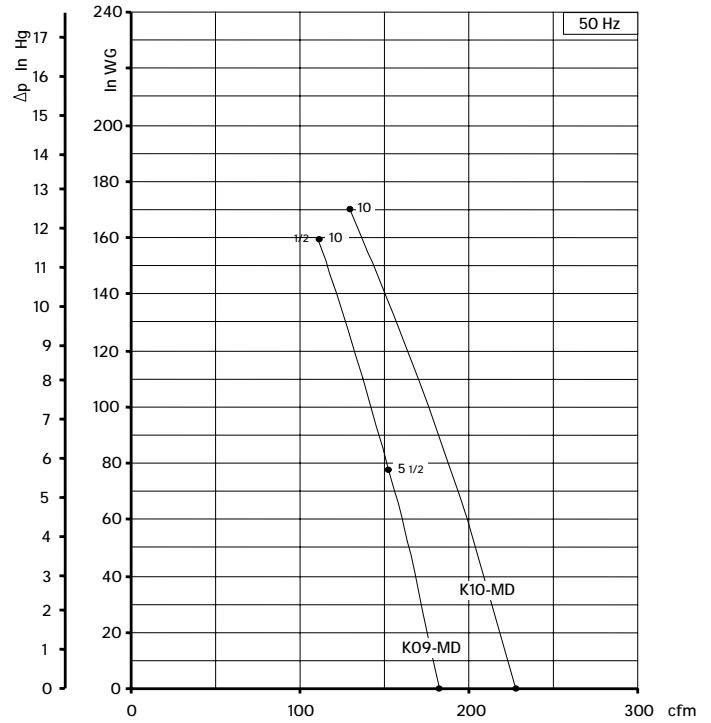
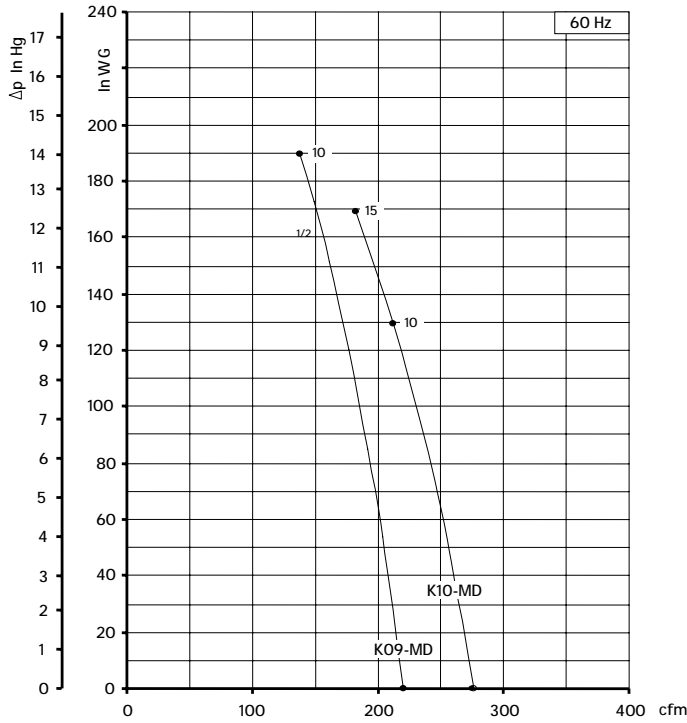

Curves refer to air at 68° F temperature, measured at inlet port and 29.92 In Hg atmospheric backpressure (abs).  
 Values for flow, power consumption and temperature rise: +/-10% tolerance.  
 Data subject to change without notice.



SCL K05 / K06

TD SERIES

SN 1936-8B 1/2

TECHNICAL CHARACTERISTICS

- Aluminium alloy construction
- Smooth operation
- High efficiency impeller
- Maintenance free
- Mountable in any position
- Recognized TEFC - cURus motor

OPTIONS

- Special voltages (IEC 38)
- Surface treatments

ACCESSORIES

- Inlet and/or inline filters
- Additional inlet/outlet silencers
- Safety valves
- Flow converting device
- Optional connectors

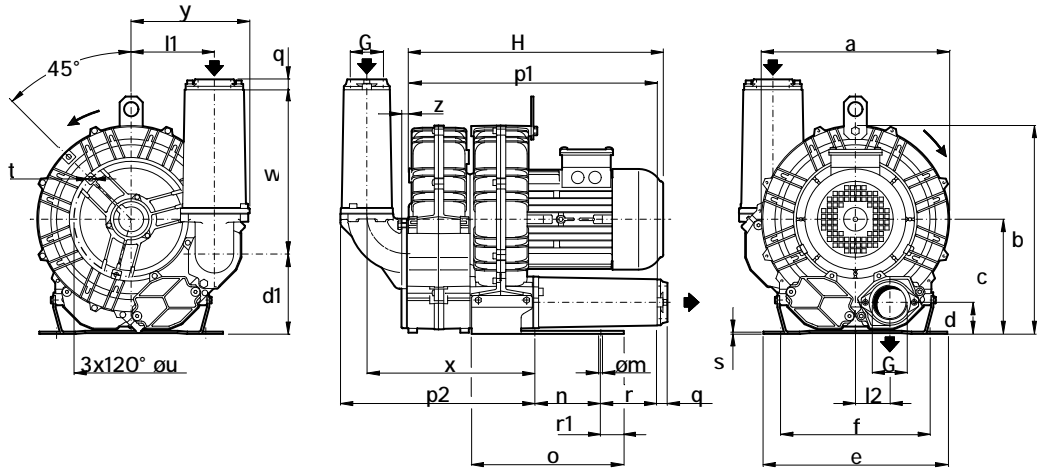

Dimensions in inches.  
Dimension for reference only.

Model	a	b	c	d	d1	e	f	G	l1	l2	m	n	o	p1	p2	q	r	r1	s	t	u	w	x	y	z
K05-TD	12.87	14.37	7.87	2.13	5.51	12.60	10.24	2" NPT	5.71	2.36	0.59	4.53	10.43	16.85	13.39	0.71	3.86	1.57	0.16	M8	7.87	11.26	11.54	8.11	0.75
K06-TD	14.80	16.54	9.13	2.32	6.69	12.80	11.42	2" NPT	5.94	2.87	0.59	5.51	10.43	19.92	13.94	0.71	5.35	0.75	0.16	M8	9.45	11.26	12.13	8.27	0.75

Model	Maximum flow cfm		Installed power Hp		Maximum differential pressure Δp (In Hg)		Noise level Lp dB (A) (1)		Overall dimensions H Inches	Weight Lbs
	60 Hz 3500 rpm	50 Hz 2900 rpm	60 Hz 3500 rpm	50 Hz 2900 rpm	60 Hz 3500 rpm	50 Hz 2900 rpm	60 Hz 3500 rpm	50 Hz 2900 rpm		
K05-TD	153	127	5 ½	5 ½	11.0	11.8	75.6	73.6	19.5	101.0
K06-TD	222	184	10	10	11.8	11.8	76.6	74.4	24.5	174.5

(1) Noise measured at 1 m distance with inlet and outlet ports piped, in accordance to ISO 3744.

- For proper use, the blower should be equipped with inlet filter and safety valve; other accessories available on request.
- Ambient temperature from +5° to +104°F.
- Specifications subject to change without notice.





SCL K05 / K06  
TD SERIES  
SN 1936-BB 2/2

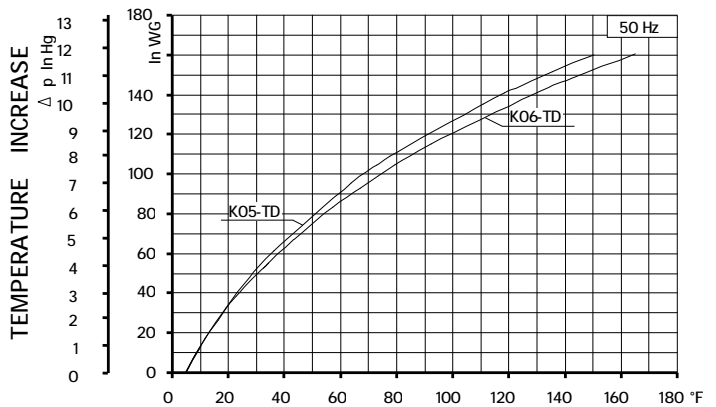
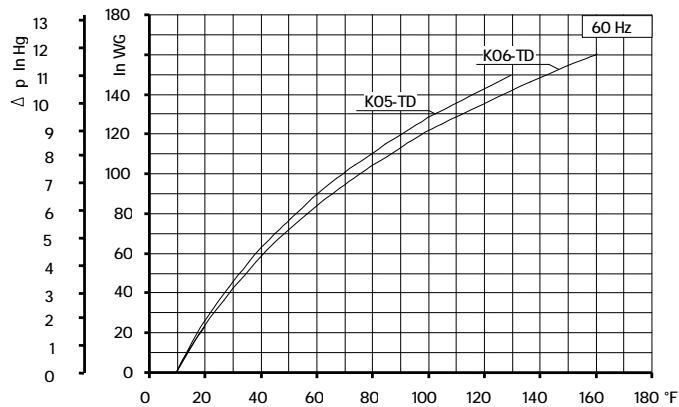
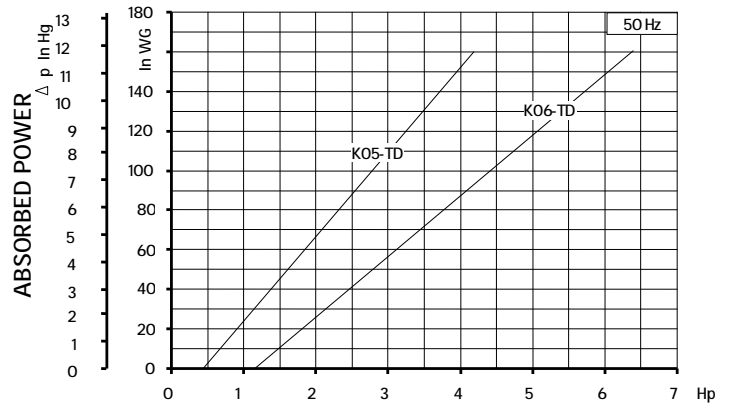
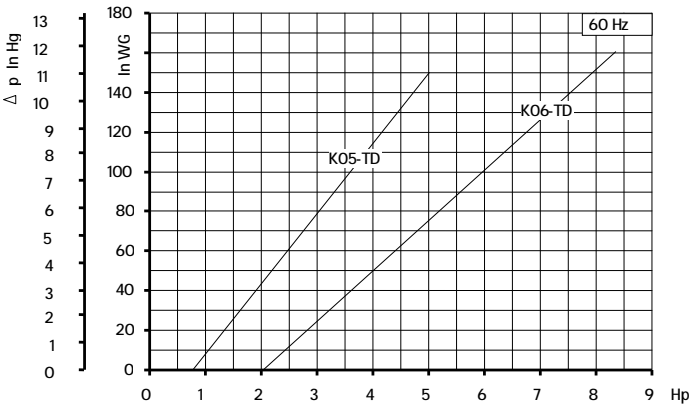
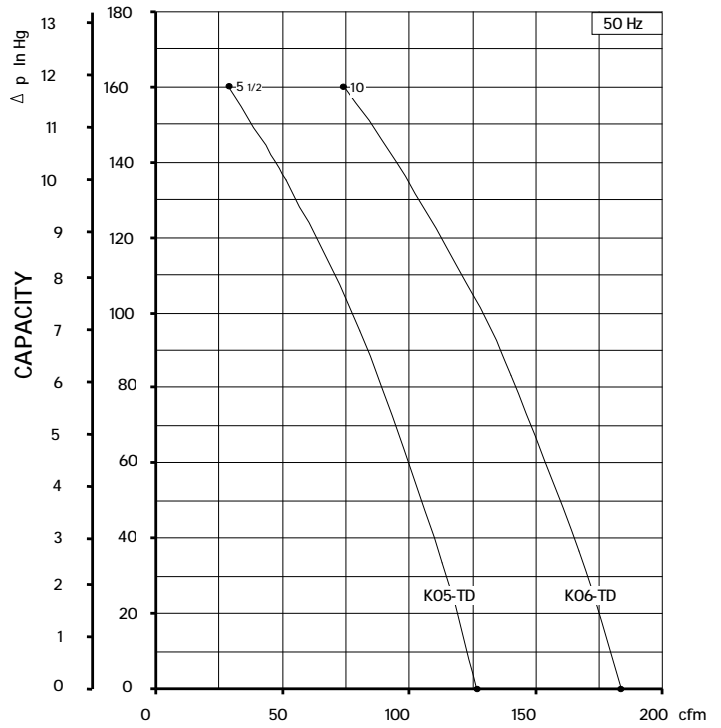
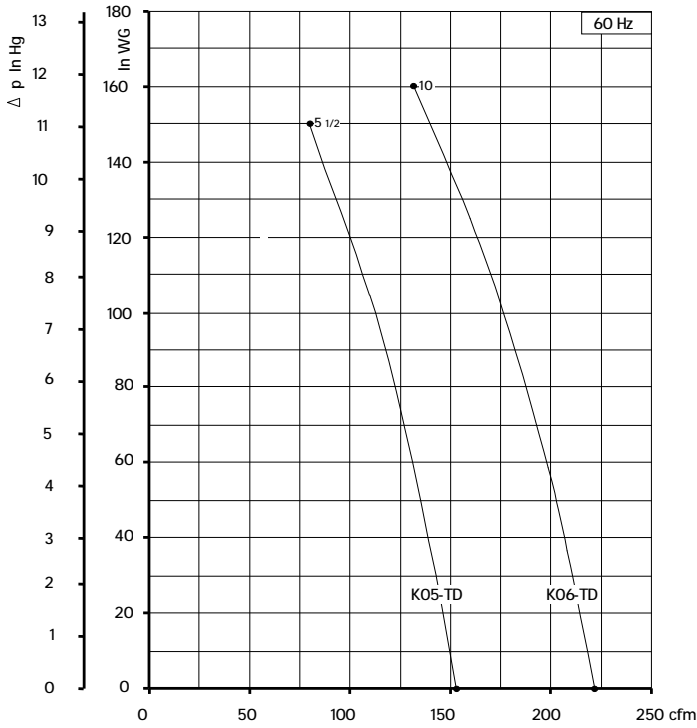

Curves refer to air at 68° F temperature, measured at inlet port and 29.92 In Hg atmospheric backpressure (abs).  
 Values for flow, power consumption and temperature rise: +/-10% tolerance.  
 Data subject to change without notice.



**TECHNICAL CHARACTERISTICS**

- Aluminium alloy construction
- Smooth operation
- High efficiency impeller
- Maintenance free
- Mountable in any position
- Recognized TEFC - cURus motor
- G1/8" female thread on both suction and discharge silencer port flanges

**OPTIONS**

- Special voltages (IEC 38)
- Surface treatments

**ACCESSORIES**

- Inlet and/or inline filters
- Additional inlet/outlet silencers
- Safety valves
- Flow converting device
- Optional connectors

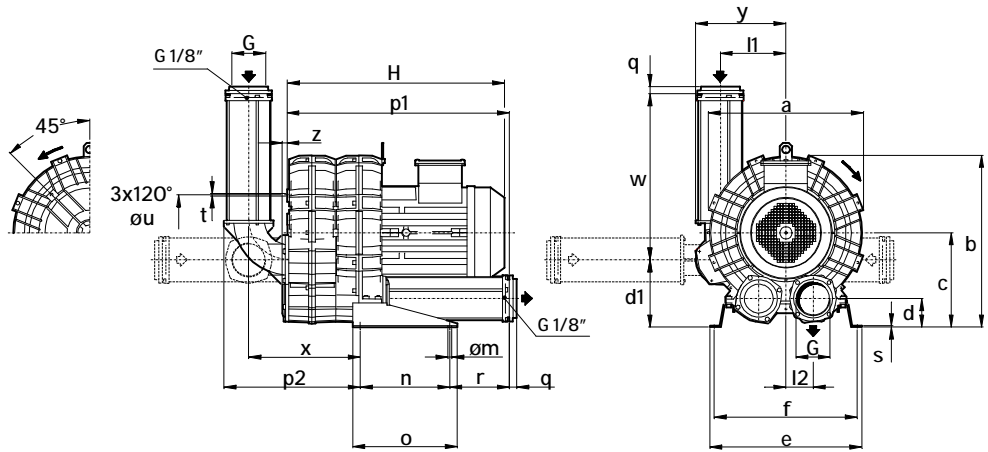

Dimensions in inches.  
Dimension for reference only.

Model	a	b	c	d	d1	e	f	G	l1	l2	m	n	o	p1	p2	q	r	s	t	u	w	x	y	z
K09-TD	19.37	22.09	12.4	3.78	8.86	20.0	18.82	4"NPT	8.66	3.58	0.51	11.81	13.78	29.33	17.91	0.98	7.83	0.20	M8	14.17	21.89	14.65	11.89	0.63
K10-TD	20.31	22.56	12.4	3.78	8.86	20.0	8.82	4"NPT	8.66	3.58	0.51	11.81	13.78	29.33	17.91	0.98	7.83	0.20	M8	14.17	21.89	14.65	11.89	0.63

Model	Maximum flow cfm		Installed power Hp		Maximum differential pressure $\Delta p$ (In Hg)		Noise level Lp dB (A) (1)		Overall dimensions H Inches	Weight Lbs
	60 Hz 3500 rpm	50 Hz 2900 rpm	60 Hz 3500 rpm	50 Hz 2900 rpm	60 Hz 3500 rpm	50 Hz 2900 rpm	60 Hz 3500 rpm	50 Hz 2900 rpm		
K09-TD	467	387	25	-	14.0	13.3	82.8	-	30.0	406.0
K10-TD	571	473	25	25	13.3	13.3	86.5	84.5	30.0	412.0

(1) Noise measured at 1 m distance with inlet and outlet ports piped, in accordance to ISO 3744.

- For proper use, the blower should be equipped with inlet filter and safety valve; other accessories available on request.
- Ambient temperature from +5° to +104°F.
- Specifications subject to change without notice.



SCL K09 / K10  
TD SERIES

SN 1834-14 2/2

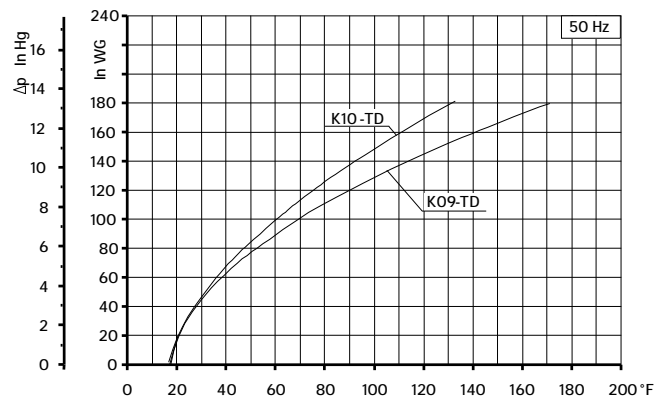
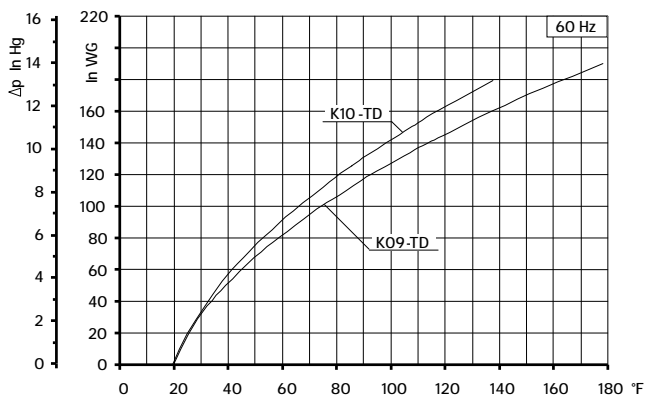
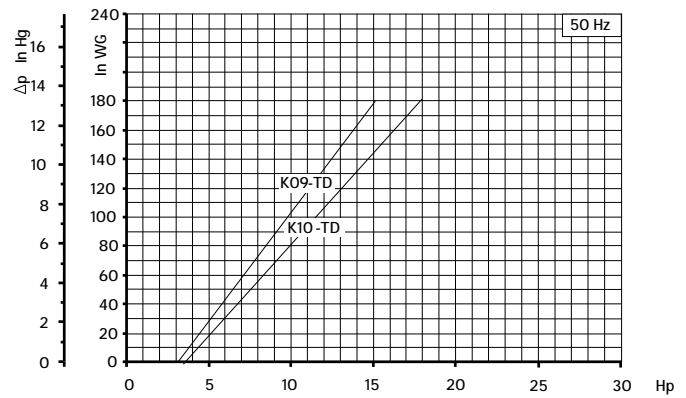
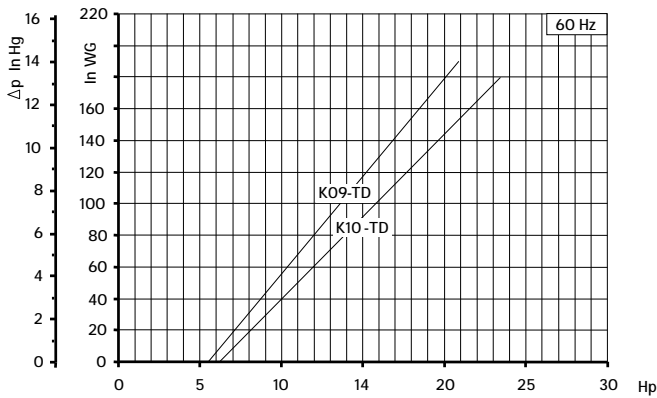
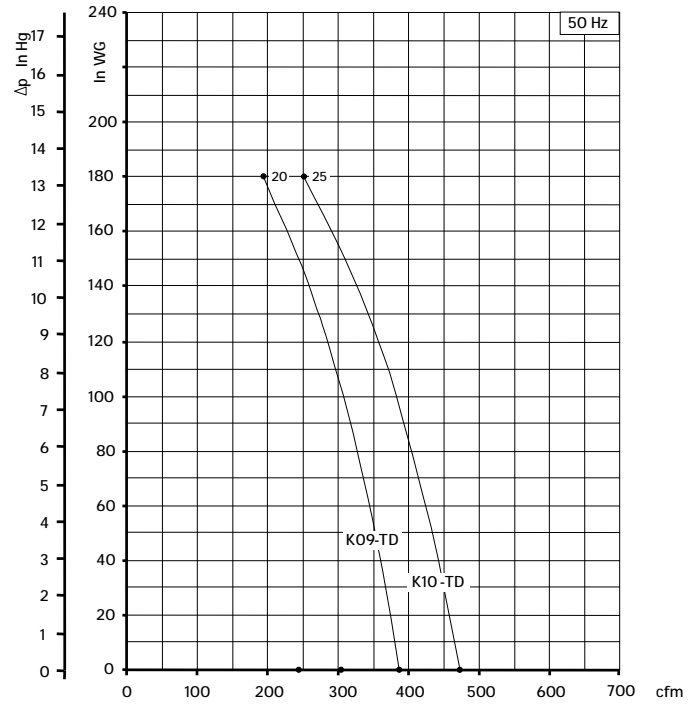
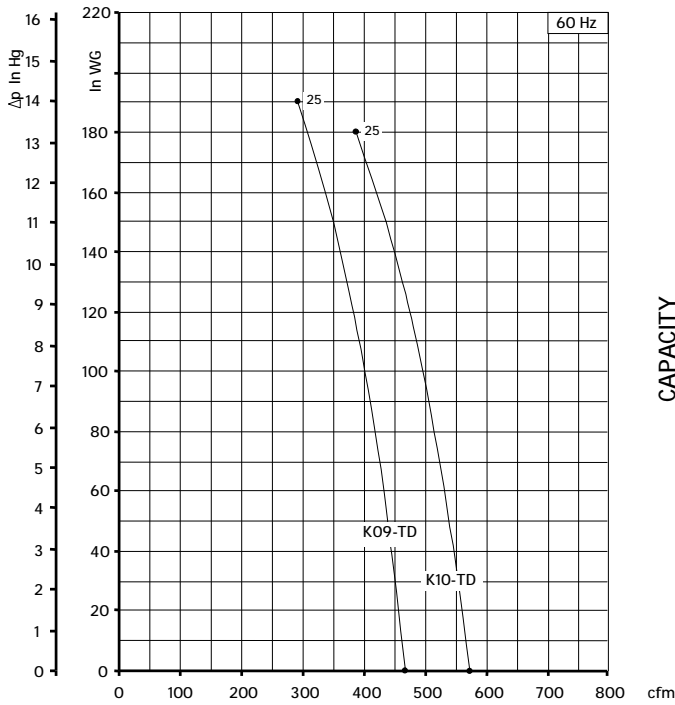

Curves refer to air at 68°F temperature, measured at inlet port and 29.92 In Hg atmospheric backpressure (abs).  
Values for flow, power consumption and temperature rise +/-10% tolerance.  
Data subject to change without notice.



**STANDARD FEATURES**

- Low weight cast aluminum construction.
- Quiet operation with integral inlet and outlet muffling.
- Recognized TEFC - cURus motor.
- High efficiency / low noise impeller design.
- No lubrication / maintenance required.
- Allowed ambient: +5 °F to +104 °F.
- Mountable in any plane.

**OPTIONS**

- Special voltages.
- Surface treatment or plating.
- Gas tight sealing.
- Special designs available.

**ACCESSORIES**

- Inlet and/or inline filters.
- Additional inlet/outlet silencers.
- Safety valves.
- Flow converting devices.
- Optional connectors

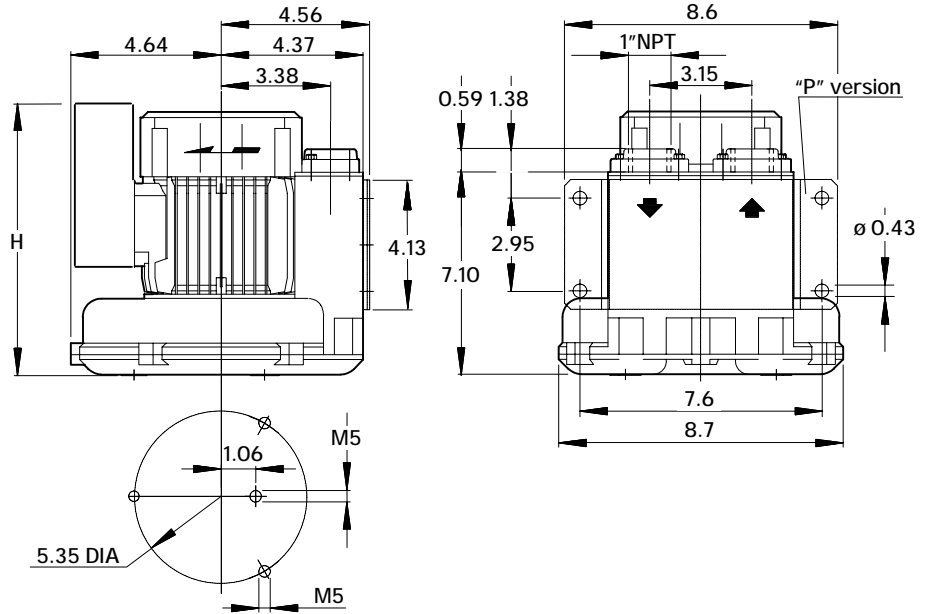

Dimensions in inches.  
Dimension for reference only.

Model	Maximum flow cfm		Installed power Hp		Maximum differential pressure $\Delta p$ (In Hg)		Noise level Lp dB (A) (1)		Overall dimensions H Inches	Weight Lbs
	60 Hz 3500 rpm	50 Hz 2900 rpm	60 Hz 3500 rpm	50 Hz 2900 rpm	60 Hz 3500 rpm	50 Hz 2900 rpm	60 Hz 3500 rpm	50 Hz 2900 rpm		
06	39	32	1/3	-	2.7	-	58.7	-	10.60	18.30
			1/2	1/2	3.5	2.4	59.0	58.0	10.60	18.50

(1) Noise measured at 1 m distance with inlet and outlet ports piped, in accordance to ISO 3744.

- For proper use, the blower should be equipped with inlet filter and safety valve; other accessories available on request.
- Ambient temperature from +5° to +104°F.
- Specifications subject to change without notice.

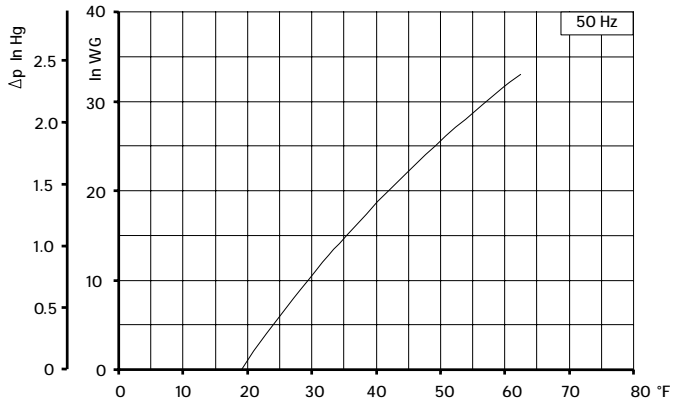
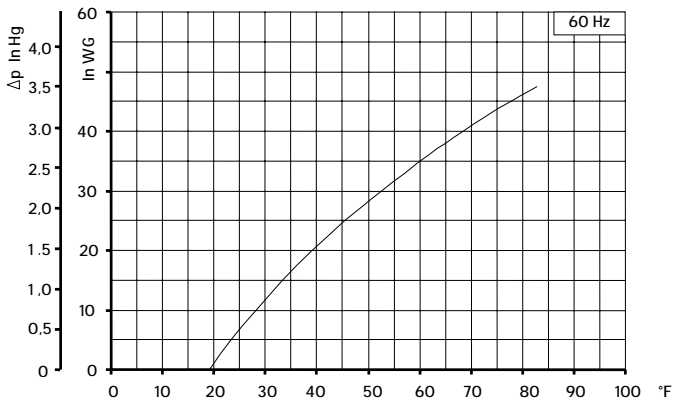
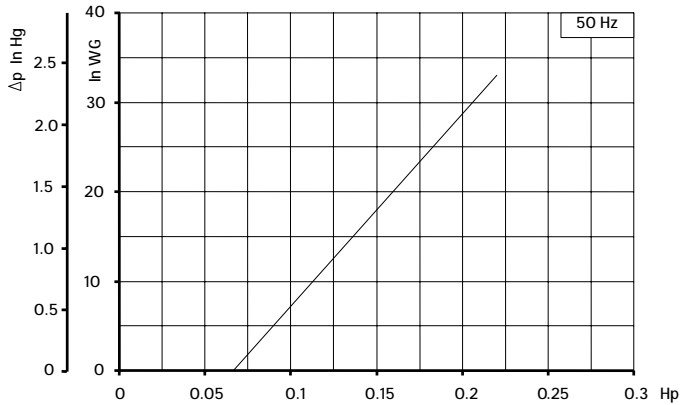
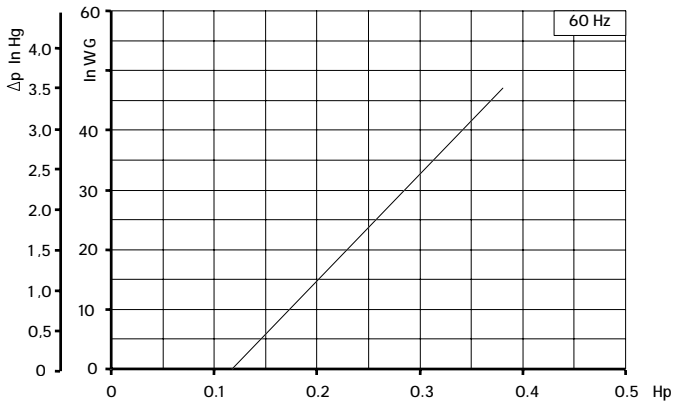
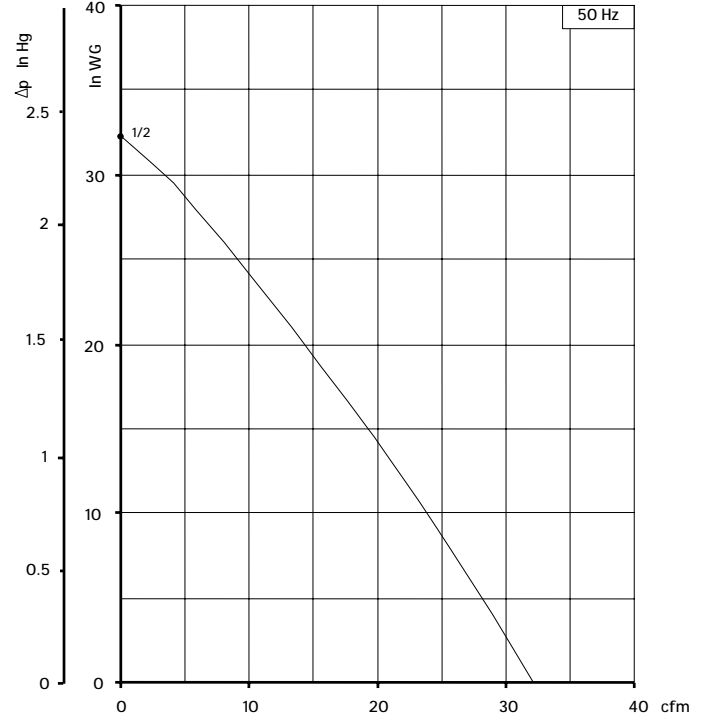
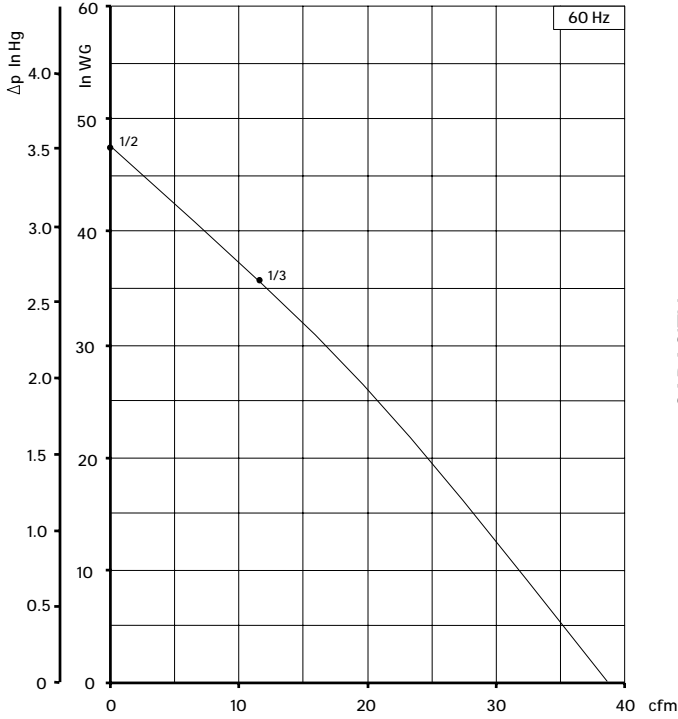

Curves refer to air at 68° F temperature, measured at inlet port and 29.92 In Hg atmospheric backpressure (abs).  
 Values for flow, power consumption and temperature rise: +/-10% tolerance.  
 Data subject to change without notice.



**STANDARD FEATURES**

- Low weight cast aluminum construction.
- Quiet operation with integral inlet and outlet muffling.
- Recognized TEFC - cURus motor.
- High efficiency / low noise impeller design.
- No lubrication / maintenance required.
- Allowed ambient: +5 °F to +104 °F.
- Mountable in any plane.

**OPTIONS**

- Remote drive models (belt or coupling).
- Special voltages.
- Surface treatment or plating.
- Gas tight sealing.
- Special designs available.

**ACCESSORIES**

- Inlet and/or inline filters.
- Additional inlet/outlet silencers.
- Safety valves.
- Flow converting devices.
- Optionals connectors

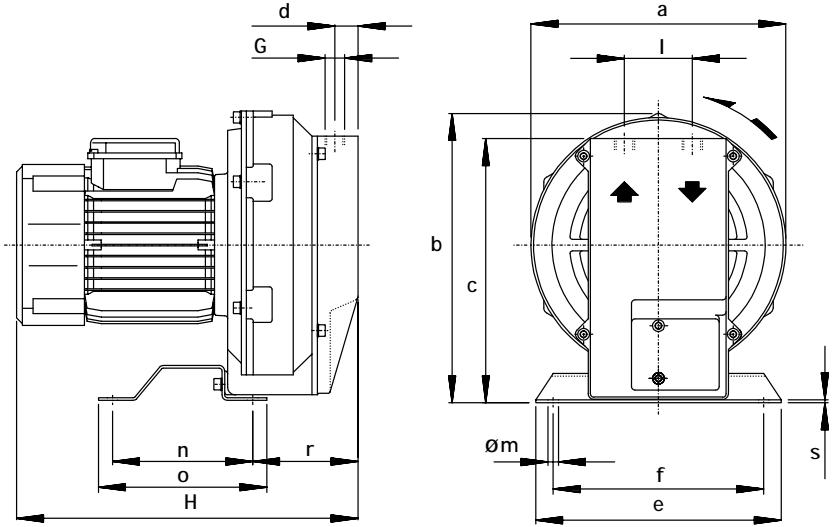

Dimensions in inches.  
Dimension for reference only.

Model	a	b	c	d	e	f	G	l	m	n	o	r	s
15DH-MD	9.84	11.26	0.16	1.18	8.27	7.09	3/4" NPT	2.52	0.35	4.72	5.67	4.72	0.10

Model	Maximum flow cfm		Installed power Hp		Maximum differential pressure Δp (In Hg)		Noise level Lp dB (A) <sup>(1)</sup>		Overall dimensions H Inches	Weight Lbs
	60 Hz 3500 rpm	50 Hz 2900 rpm	60 Hz 3500 rpm	50 Hz 2900 rpm	60 Hz 3500 rpm	50 Hz 2900 rpm	60 Hz 3500 rpm	50 Hz 2900 rpm		
15DH-MD	35	29	3/4	3/4	7.2	7.7	63.7	61.7	14.25	32.50
			1	1	8.1	8.1	64.0	62.0	15.75	40.00

(1) Noise measured at 1 m distance with inlet and outlet ports piped, in accordance to ISO 3744.

- For proper use, the blower should be equipped with inlet filter and safety valve; other accessories available on request.
- Ambient temperature from +5° to +104°F.
- Specifications subject to change without notice.

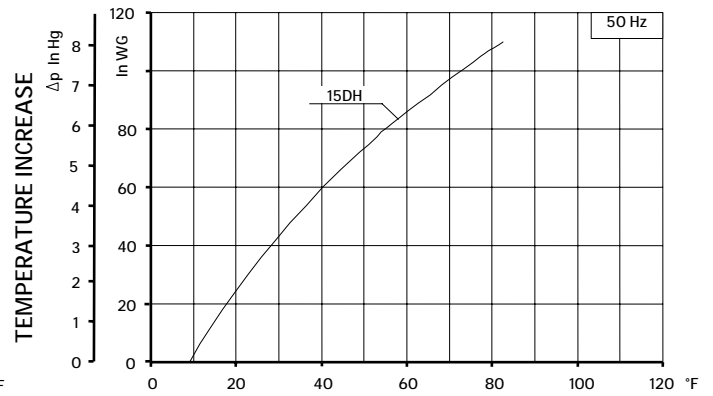
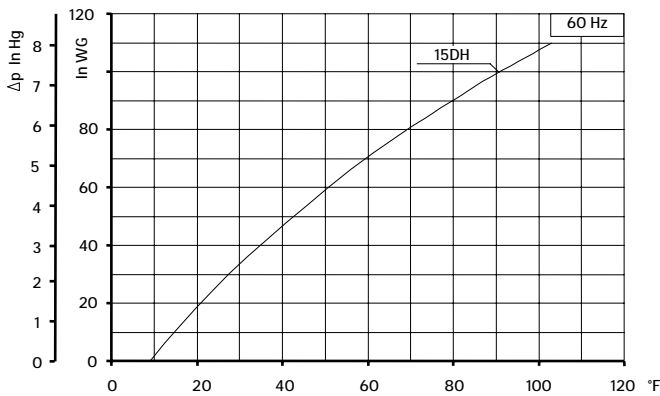
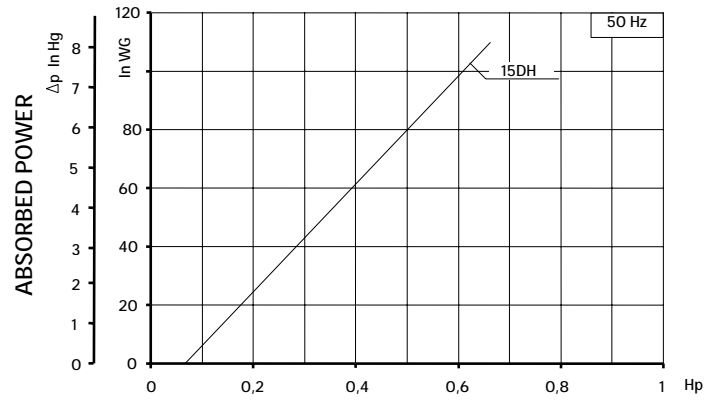
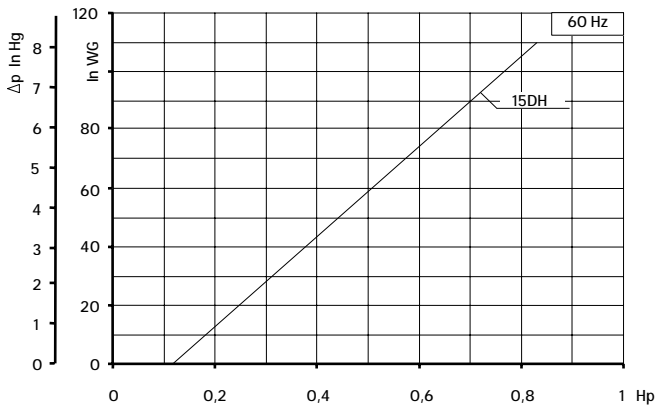
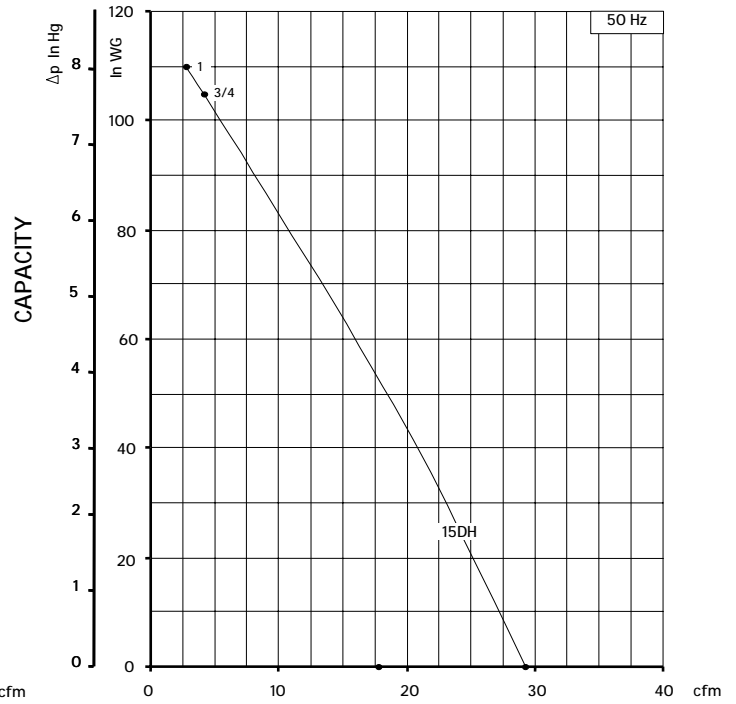
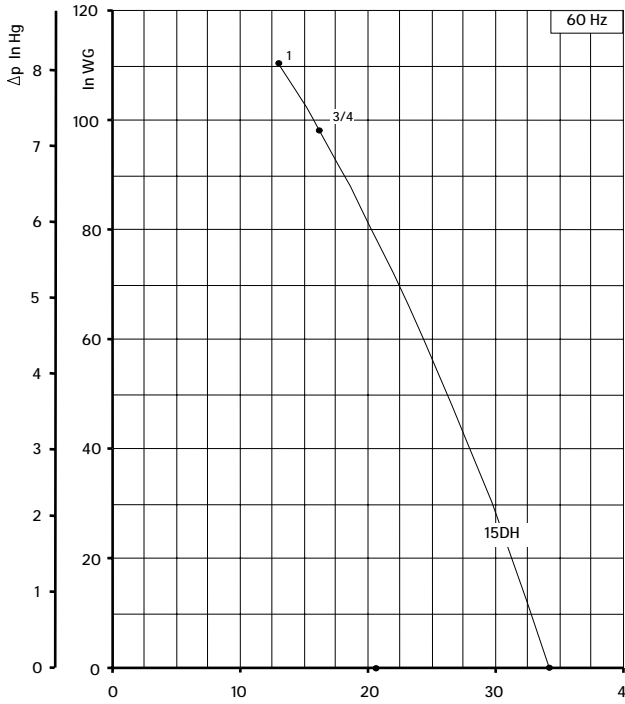

Curves refer to air at 68° F temperature, measured at inlet port and 29.92 In Hg atmospheric backpressure (abs).  
 Values for flow, power consumption and temperature rise: +/-10% tolerance.  
 Data subject to change without notice.



**STANDARD FEATURES**

- Low weight cast aluminum construction.
- Quiet operation with integral inlet and outlet muffling.
- Recognized TEFC - cURus motor.
- High efficiency / low noise impeller design.
- No lubrication / maintenance required.
- Allowed ambient: +5 °F to +104 °F.
- Mountable in any plane.

**OPTIONS**

- Remote drive models (belt or coupling).
- Special voltages.
- Surface treatment or plating.
- Gas tight sealing.
- Special designs available.

**ACCESSORIES**

- Inlet and/or inline filters.
- Additional inlet/outlet silencers.
- Relief valves.
- Flow converting devices.
- Optionals connectors

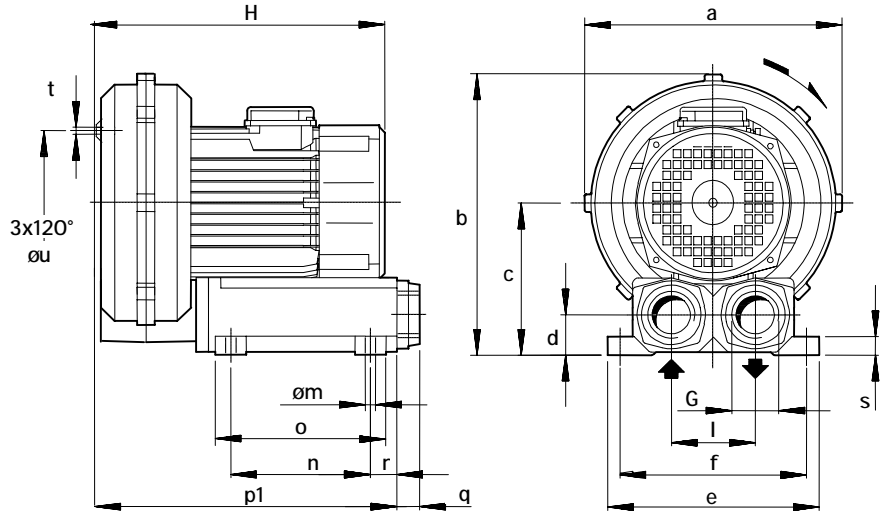

Dimensions in inches.  
Dimension for reference only.

Model	a	b	c	d	e	f	G	I	m	n	o	p1	q	r	s	t	u
R20-MD	11.14	12.17	6.57	1.85	9.25	8.27	1" ¼ NPT	3.54	0.39	5.91	7.87	13.58	0.71	1.77	0.87	M6	5.91
R30-MD	12.56	13.62	7.36	1.85	9.25	8.27	1" ¼ NPT	3.54	0.39	5.91	7.87	13.94	0.71	1.77	0.87	M6	7.09
R40-MD	13.78	14.65	7.76	1.85	9.25	8.27	1" ¼ NPT	3.54	0.39	5.91	7.87	14.33	0.71	1.77	0.87	M8	8.86

Model	Maximum flow Scfm		Installed power Hp		Maximum differential pressure Δp (In Hg)		Noise level Lp dB (A) <sup>(1)</sup>		Overall dimensions H	Weight
	60 Hz	50 Hz	60 Hz	50 Hz	60 Hz	50 Hz	60 Hz	50 Hz		
	3500 rpm	2900 rpm	3500 rpm	2900 rpm	3500 rpm	2900 rpm	3500 rpm	2900 rpm	Inches	Lbs
R20-MD	41	35	1 ½	1 ½	10.3	8.9	68.5	66.5	13.39	48.5
R30-MD	65	54	2	2	11.1	10.3	72.2	69.2	15.58	57.3
R40-MD	81	69	3	3	11.1	10.3	72.8	70.8	16.22	77.2

(1) Noise measured at 1 m distance with inlet and outlet ports piped, in accordance to ISO 3744.

- For proper use, the blower should be equipped with inlet filter and relief valve; other accessories available on request.
- Ambient temperature from +5° to +104°F.
- Specifications subject to change without notice.



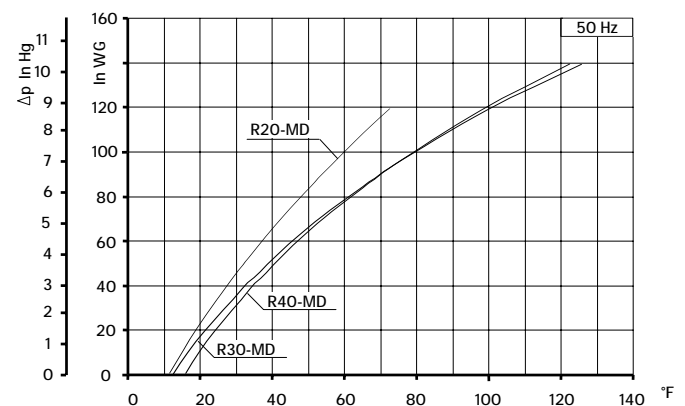
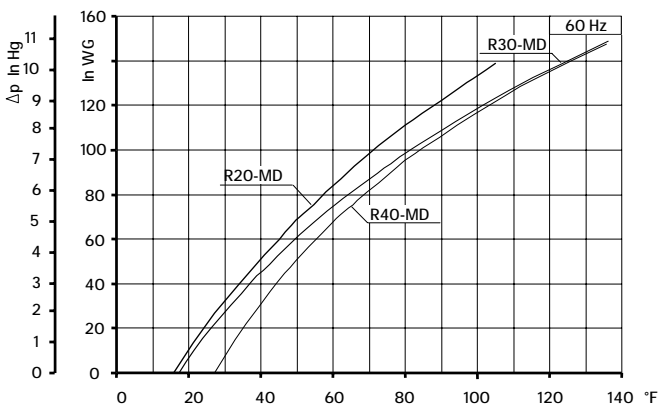
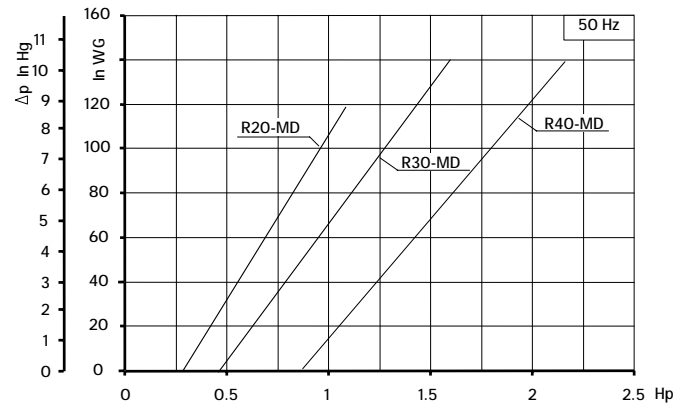
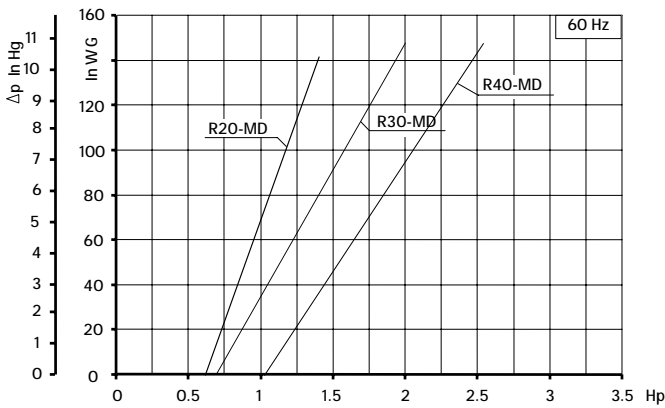
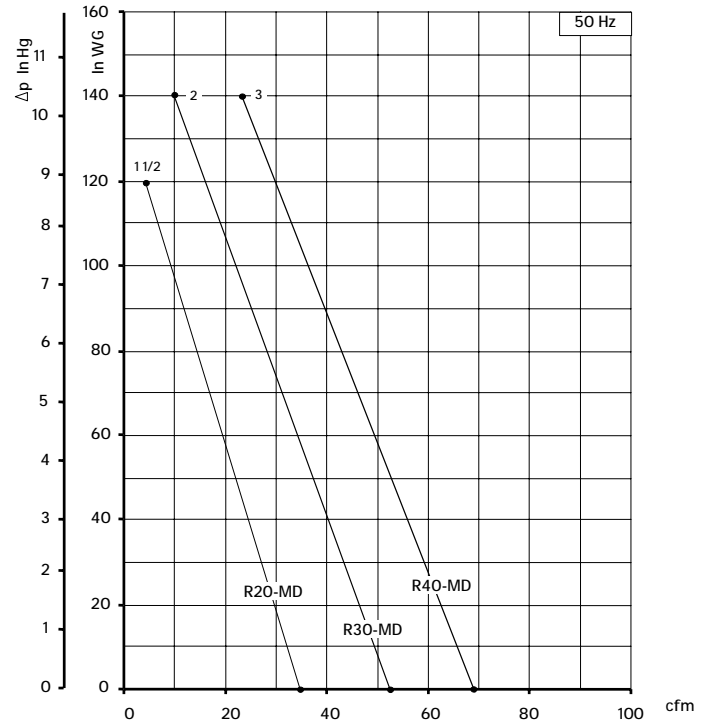
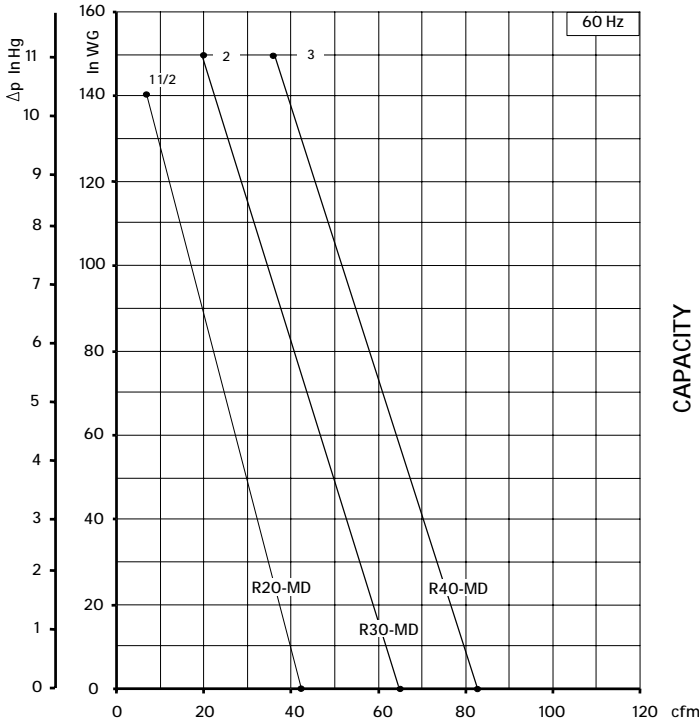

Curves refer to air at 68° F temperature, measured at inlet port and 29.92 In Hg atmospheric backpressure (abs).  
 Values for flow, power consumption and temperature rise: +/-10% tolerance.  
 Data subject to change without notice.



SCL K03 / K04 / K05 / K06  
MS SERIES - GOR/GVR RANGE  
SN 2582-2 1/2

TECHNICAL CHARACTERISTICS

- Aluminium alloy construction
- Smooth operation
- High efficiency impeller
- Maintenance free
- Mountable in any position

OPTIONS

- Special voltages (IEC 38)
- Surface treatments

ACCESSORIES

- Inlet and/or inline filters
- Additional inlet/outlet silencers
- Safety valves
- Flow converting device
- Optional connectors

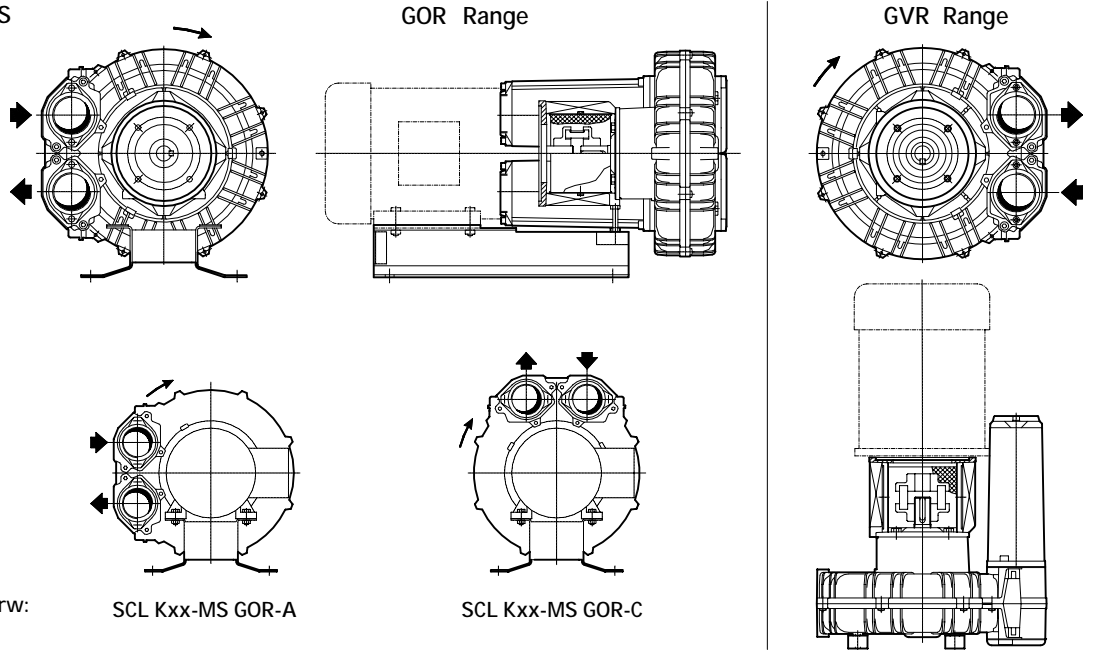

For dimensions, please refer to drw:

- GOR range: SI 1852
- GVR range: SI 1946

SCL Kxx-MS GOR-A

SCL Kxx-MS GOR-C

Model	Maximum flow cfm		Installed power Hp	Size	Maximum differential pressure $\Delta p$ ( in Hg )		Noise level Lp dB (A) (1)		Weight (2)		
	60 Hz 3500 rpm	50 Hz 2900 rpm			60 Hz 3500 rpm	50 Hz 2900 rpm	60 Hz 3500 rpm	50 Hz 2900 rpm	Lbs GOR	Lbs GVR	
K03-MS	52	43	3/4	NEMA 56C	4.7	3.7	61.0	59.0	22.00	17.60	
K04-MS	98	81	1 1/2	NEMA 56C	4.3	5.9	63.8	61.8	27.60	22.00	
			2	NEMA 56C	6.3		64.0				
			3	NEMA 56C	6.6		64.2				
K05-MS	156	129	2	NEMA 143-5TC	3.8	5.2	69.5	67.5	35.00	28.00	
			3	NEMA 143-5TC	6.6		69.8				
			5	NEMA 182-4TC	8.1		70.4				
K06-MS	216	179	3	NEMA 143-5TC	3.7	4.8	72.0	70.0	46.00	38.40	
			5	NEMA 182-4TC			6.3				72.6
			7 1/2	NEMA 182-4TC			9.6				72.9

(1) Noise measured at 1 m distance with inlet and outlet ports piped, in accordance to ISO 3744.

(2) Value is referred to weight of the machine without electric motor.

- For proper use, the blower should be equipped with inlet filter and safety valve; other accessories available on request.
- Ambient temperature from +5° to +104°F.
- Specifications subject to change without notice.



SCL K03 / K04 / K05 / K06  
MS SERIES - GOR/GVR RANGE  
SN 2582-2 2/2

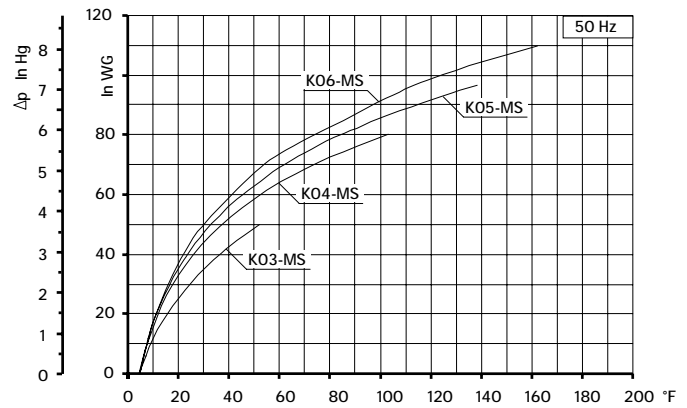
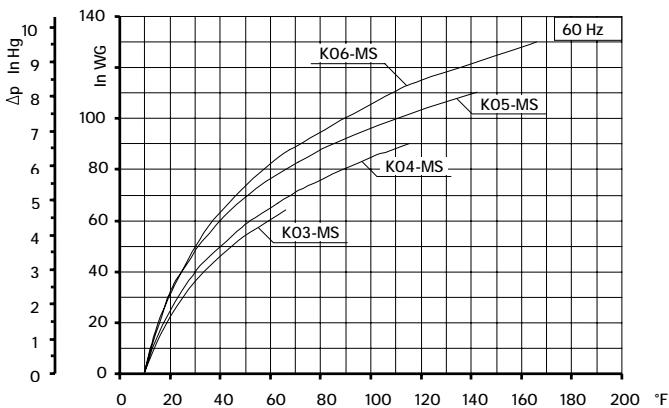
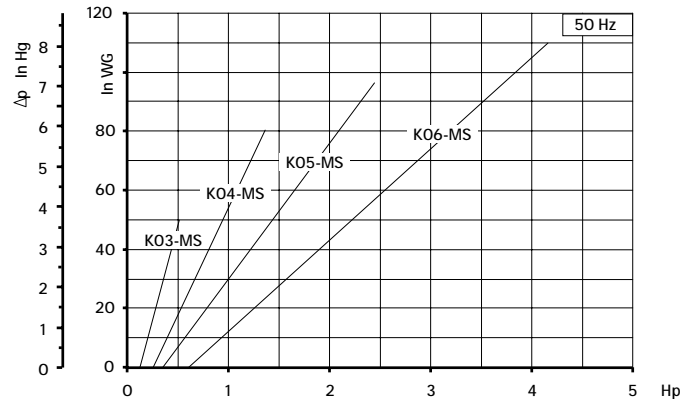
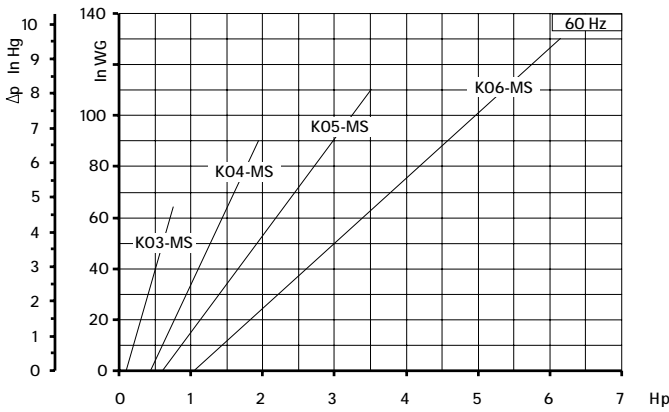
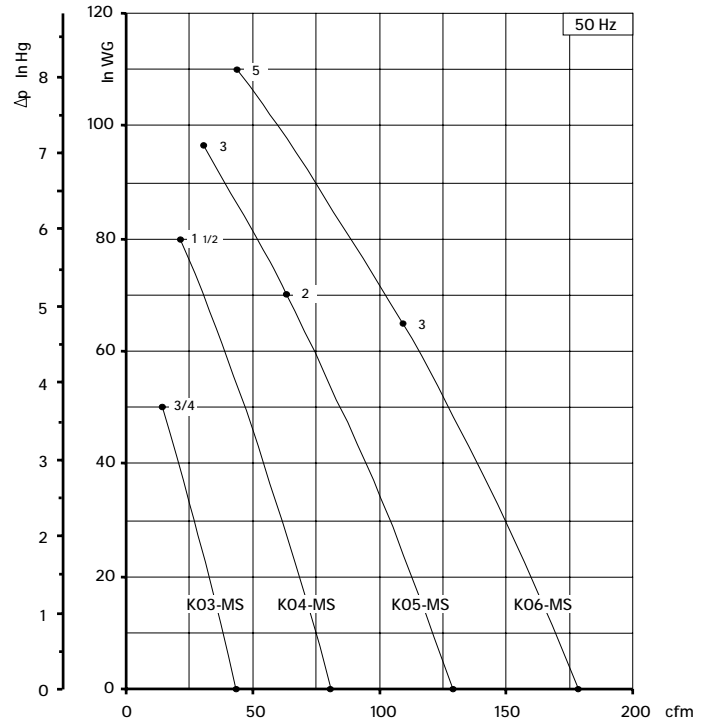
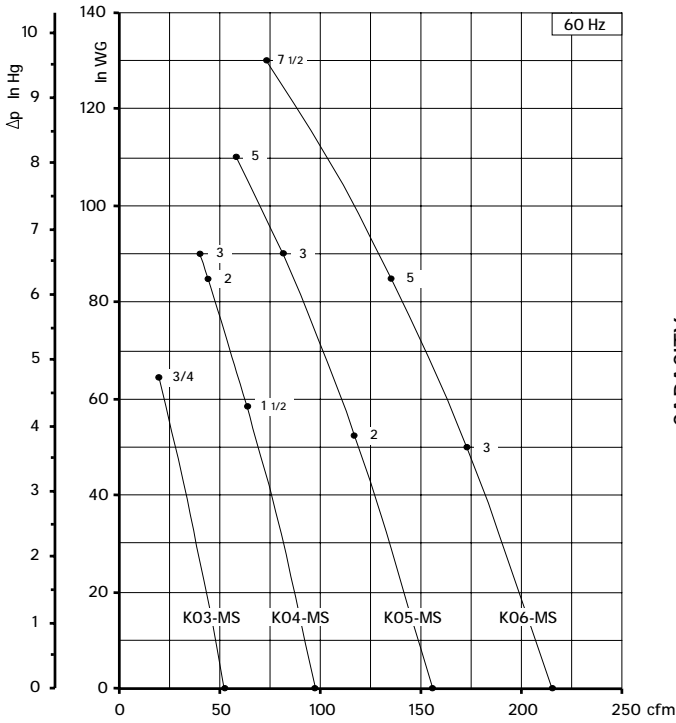

Curves refer to air at 68° F temperature, measured at inlet port and 29.92 In Hg atmospheric backpressure (abs).  
Values for flow, power consumption and temperature rise: +/-10% tolerance.  
Data subject to change without notice.



SCL K09 / K10  
MS SERIES - GOR/GVR RANGE  
SN 2135-6 1/2

TECHNICAL CHARACTERISTICS

- Aluminium alloy construction
- Smooth operation
- High efficiency impeller
- Maintenance free
- Mountable in any position

OPTIONS

- Special voltages (IEC 38)
- Surface treatments

ACCESSORIES

- Inlet and/or inline filters
- Additional inlet/outlet silencers
- Safety valves
- Flow converting device
- Optional connectors

For dimensions, please refer to drw:

GOR range: SI 1873

GVR range: SI 1920

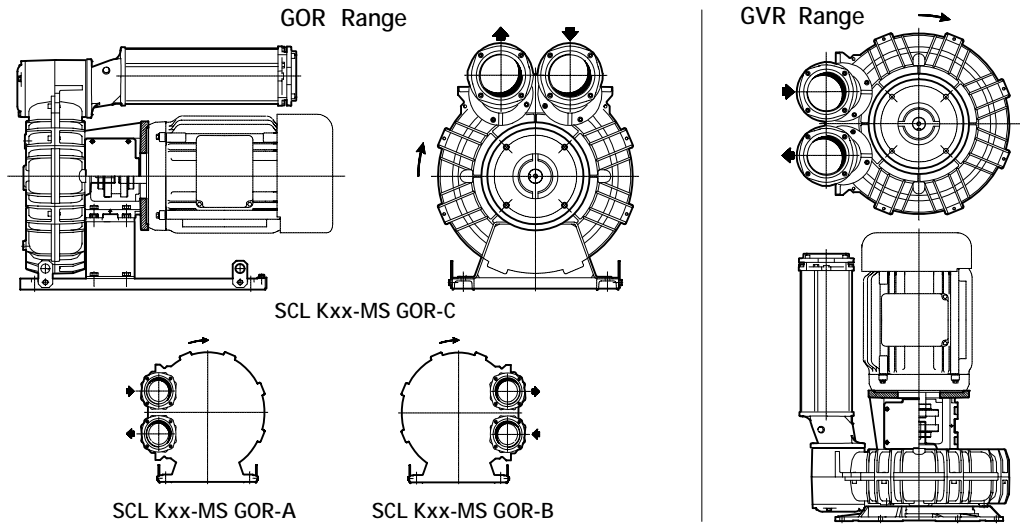

Model	Maximum flow cfm		Installed power Hp	Size	Maximum differential pressure $\Delta p$ (in Hg)		Noise level Lp dB (A) <sup>(1)</sup>		Weight <sup>(2)</sup> Lbs
	60 Hz	50 Hz			60 Hz	50 Hz	60 Hz	50 Hz	
	3500 rpm	2900 rpm			3500 rpm	2900 rpm	3500 rpm	2900 rpm	
K09-MS	471	390	7 1/2	NEMA 182-4TC	3.7	4.6	79.3	77.3	133.40
				NEMA 213-5TC					133.40
			10	NEMA 213-5TC	5.9	7.0	79.6	77.6	133.40
			15	NEMA 213-5TC	10.3	9.6	80.1	78.1	133.40
	NEMA 254-6TC	80.4	137.00						
K10-MS	556	460	7 1/2	NEMA 182-4TC	2.2	3.7	79.4	77.4	147.30
				NEMA 213-5TC					147.30
			10	NEMA 213-5TC	4.4	5.9	79.7	77.7	147.30
			15	NEMA 213-5TC	8.1	9.6	80.2	78.2	147.30
				NEMA 254-6TC					151.00
			20	NEMA 254-6TC	10.3		80.5		151.00

(1) Noise measured at 1 m distance with inlet and outlet ports piped, in accordance to ISO 3744.

(2) Value is referred to weight of the machine without electric motor

- For proper use, the blower should be equipped with inlet filter and safety valve; other accessories available on request.
- Ambient temperature from +5° to +104°F.
- Specifications subject to change without notice.



SCL K09 / K10  
MS SERIES - GOR/GVR RANGE

SN 2135-6 2/2

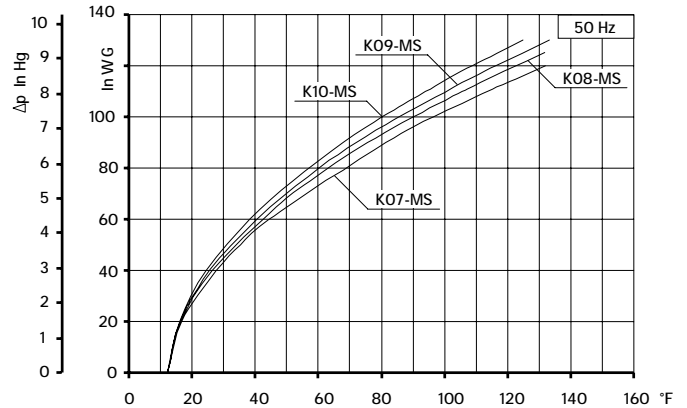
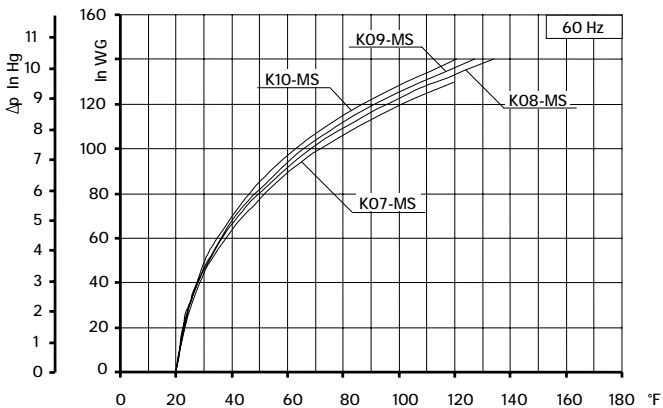
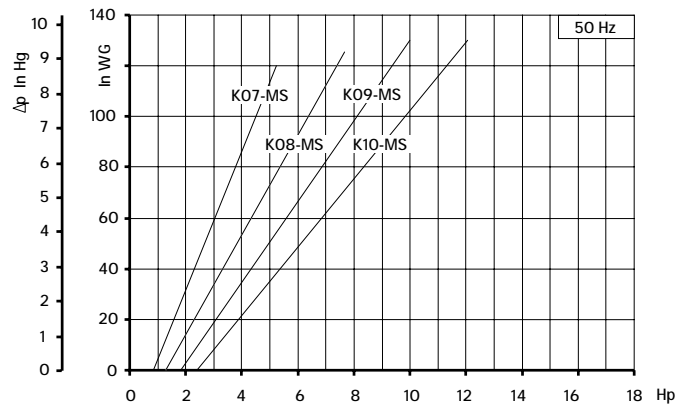
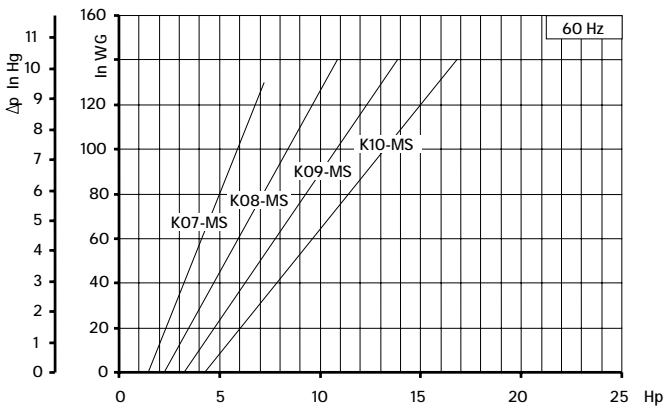
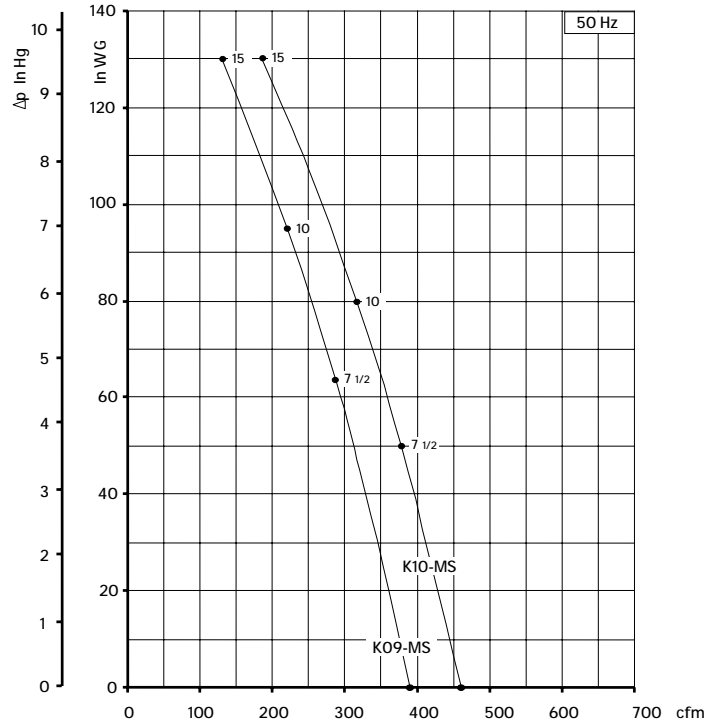
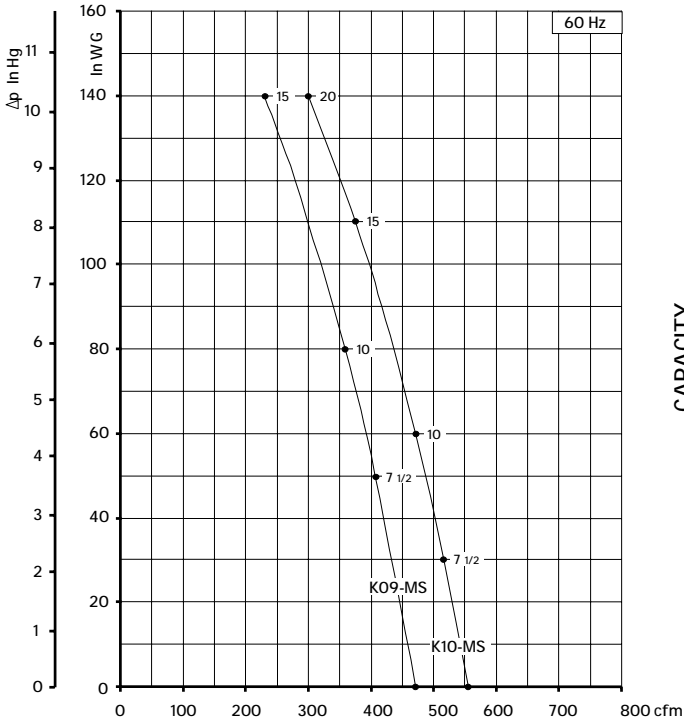

Curves refer to air at 68° F temperature, measured at inlet port and 29.92 In Hg atmospheric backpressure (abs).  
Values for flow, power consumption and temperature rise: +/-10% tolerance.  
Data subject to change without notice.



SCL K05 / K06  
 TS SERIES - GOR / GVR USA RANGE  
 SN 2688-2 1/2

TECHNICAL CHARACTERISTICS

- Aluminium alloy construction
- Smooth operation
- High efficiency impeller
- Maintenance free
- Mountable in any plane
- G1/8" female thread on both suction and discharge silencer port flanges.

OPTIONS

- Special voltages (IEC 38)
- Surface treatments

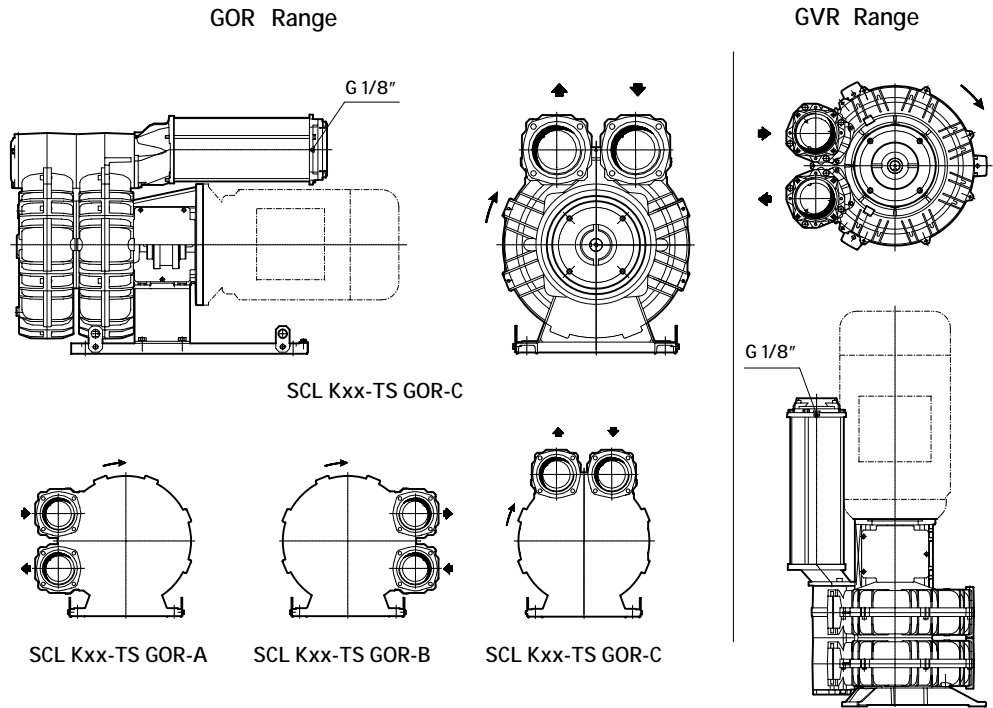

For dimensions, please refer to drw:

- GOR range: SI 21 23
- GVR range: SI 21 35

Model	Maximum flow m <sup>3</sup> /h		Installed power Hp	Size	Maximum differential pressure Δp (in Hg)		Noise level Lp dB (A) (1)		Weight (2)	
	60 Hz 3500 rpm	50 Hz 2900 rpm			60 Hz 3500 rpm	50 Hz 2900 rpm	60 Hz 3500 rpm	50 Hz 2900 rpm	Lbs	
									GOR	GVR
K05-TS	290	241	5.0	NEMA 182-4TC	4.4	6.3	75.1	73.1	72.75	68.35
			7.5		7.4	6.7	77.1	75.1		
K06-TS	400	331	7.5	NEMA 213-5TC	4.1	5.7	77.1	75.1	112.45	108.00
			10		5.9	7.4	77.4	75.4		
			15		7.8		78.0	76.0		

(1) Noise measured at 1 m distance with inlet and outlet ports piped, in accordance to ISO 3744.

(2) Value is referred to weight of the machine without electric motor.

- For proper use, the blower should be equipped with inlet filter and safety valve; other accessories available on request.
- Ambient temperature from +5° to +104°F.
- Specifications subject to change without notice.



SCL K05 / K06  
TS SERIES - GOR/GVR RANGE  
SN 2688-2 2/2

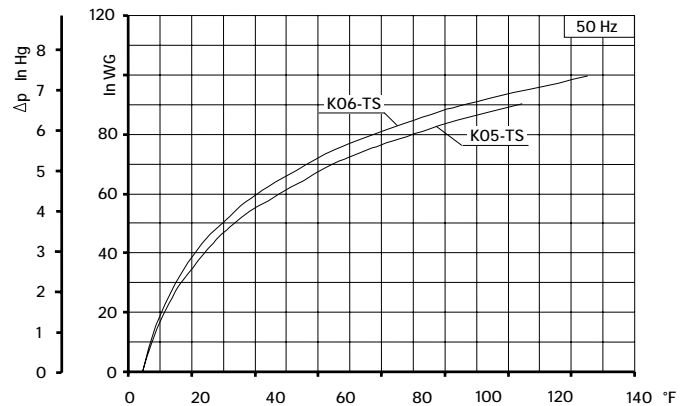
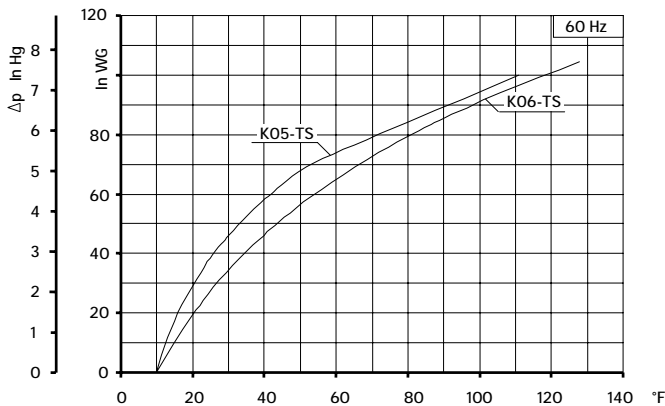
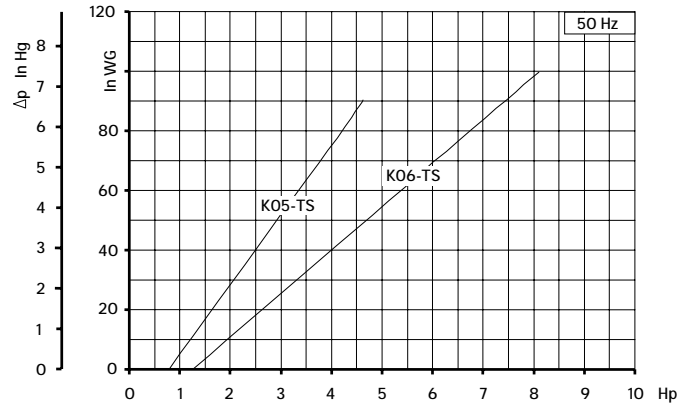
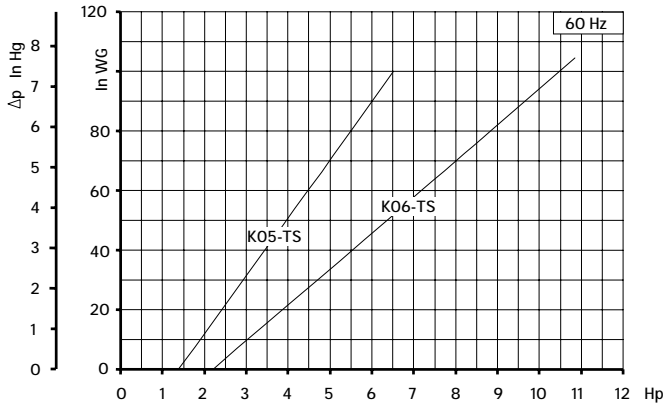
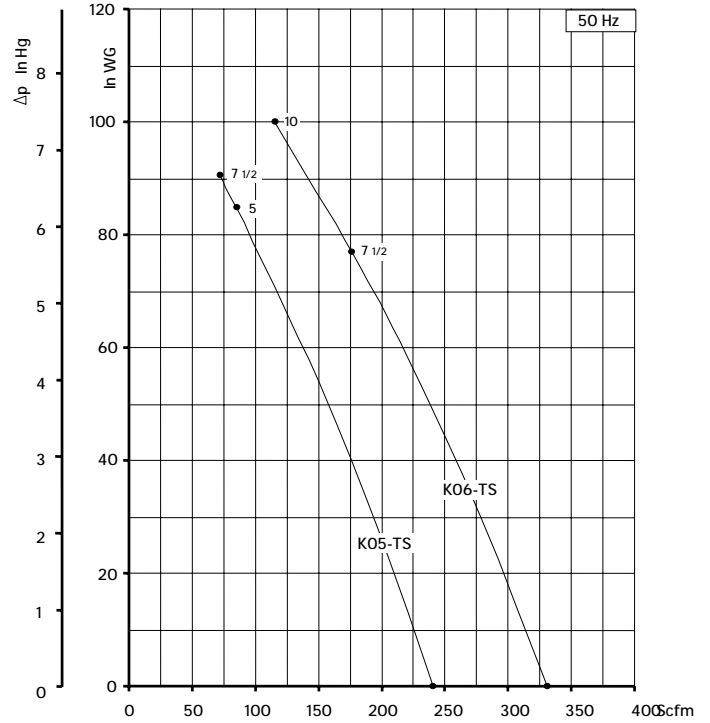
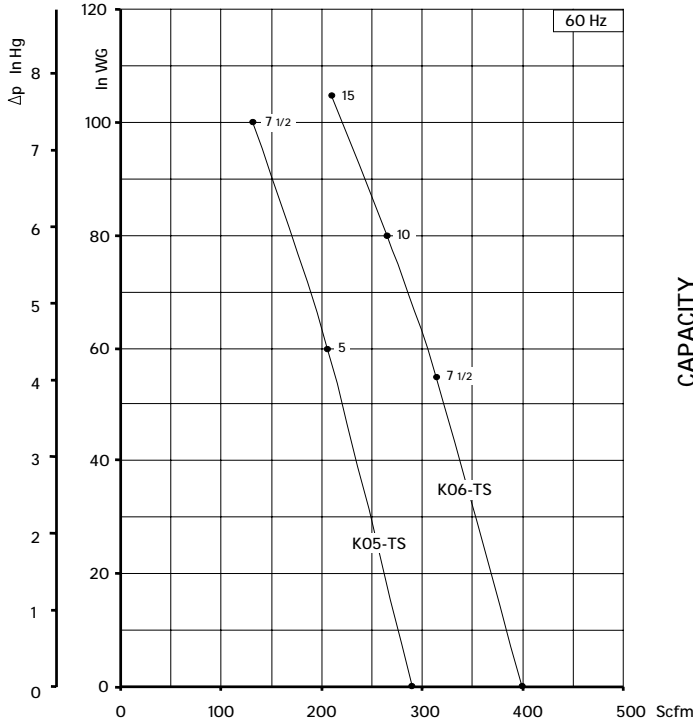

Curves refer to air at 20°C temperature, measured at inlet port and 1013 mbar (abs) atmospheric backpressure. Values for flow, power consumption and temperature rise: +/-10% tolerance. Data subject to change without notice.



SCL K09 / K10  
TS SERIES - GOR/GVR RANGE  
SN 2165-8 1/2

TECHNICAL CHARACTERISTICS

- Aluminium alloy construction
- Smooth operation
- High efficiency impeller
- Maintenance free
- Mountable in any position
- G1/8" female thread on both suction and discharge silencer port flanges

OPTIONS

- Special voltages (IEC 38)
- Surface treatments

ACCESSORIES

- Inlet and/or inline filters
- Additional inlet/outlet silencers
- Safety valves
- Flow converting device
- Optional connectors

For dimensions, please refer to drw:

GOR range: SI 1879

GVR range: SI 1880

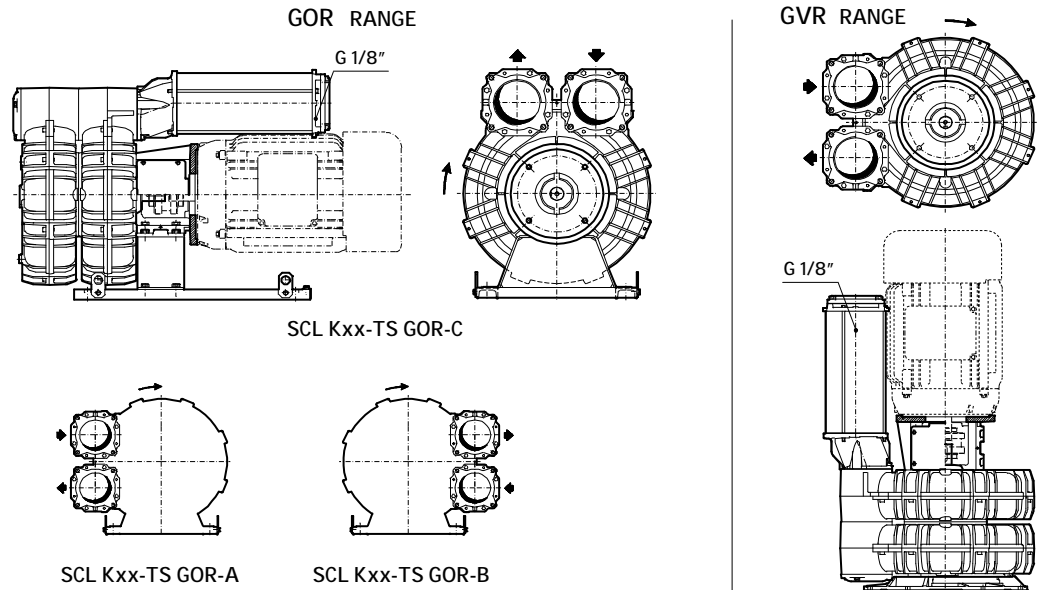

Model	Maximum flow cfm		Installed power Hp	Size	Maximum differential pressure $\Delta p$ (In Hg)		Noise level Lp dB (A) (1)		Weight (2) Lbs
	60 Hz 3500 rpm	50 Hz 2900 rpm			60 Hz 3500 rpm	50 Hz 2900 rpm	60 Hz 3500 rpm	50 Hz 2900 rpm	
K09-TS	941	780	15	NEMA 213-5TC	3.8	5.5	82.2	80.2	202.80
				NEMA 254-6TC	3.8	5.5	82.2	80.2	208.30
			20	NEMA 254-6TC	5.9	7.9	84.1	82.1	208.30
			25	NEMA 284-6TSC	8.1	8.8	86.1	84.1	205.00
			30	NEMA 284-6TSC	8.8	8.8	88.1	84.1	205.00
K10-TS	1093	906	15	NEMA 213-5TC	3.0	4.7	89.1	87.1	209.40
				NEMA 254-6TC	3.0	4.7	89.1	87.1	216.10
			20	NEMA 254-6TC	4.8	6.6	89.4	87.4	216.10
			25	NEMA 284-6TSC	5.9	8.1	89.7	87.7	211.60
			30	NEMA 284-6TSC	7.4	9.6	90.0	88.0	211.60
			40	NEMA 324-6TSC	10.3	9.6	90.3	88.0	227.10

(1) Noise measured at 1 m distance with inlet and outlet ports piped, in accordance to ISO 3744.

(2) Value is referred to weight of the machine without electric motor

- Specifications subject to change without notice.

- Ambient temperature from +5° to +104°F.

- For proper use, the blower should be equipped with inlet filter and safety valve; other accessories available on request.



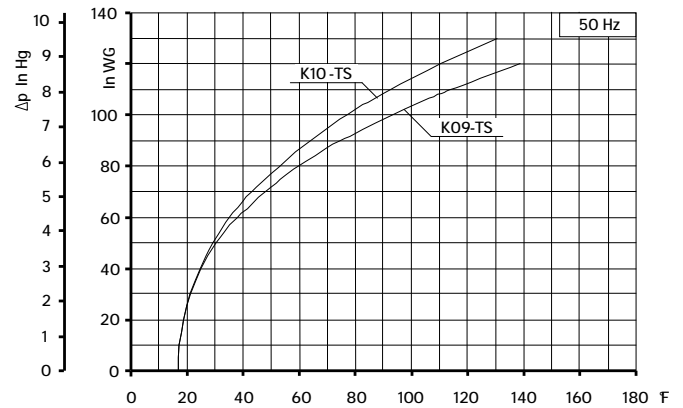
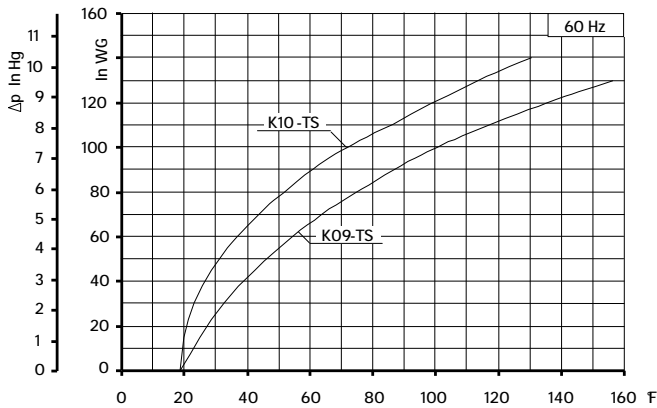
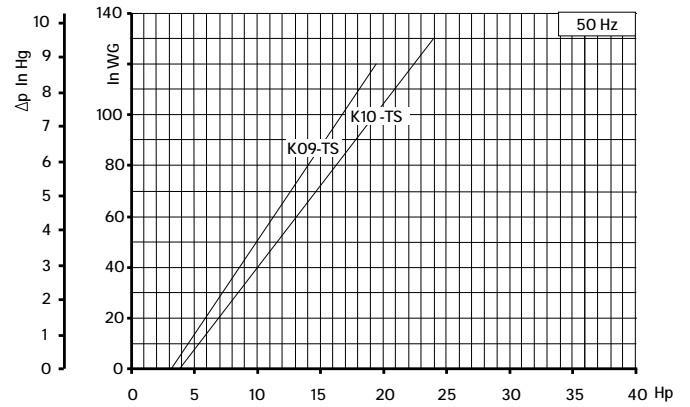
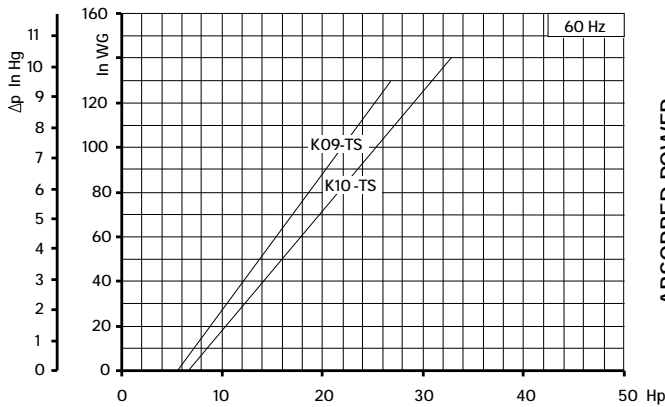
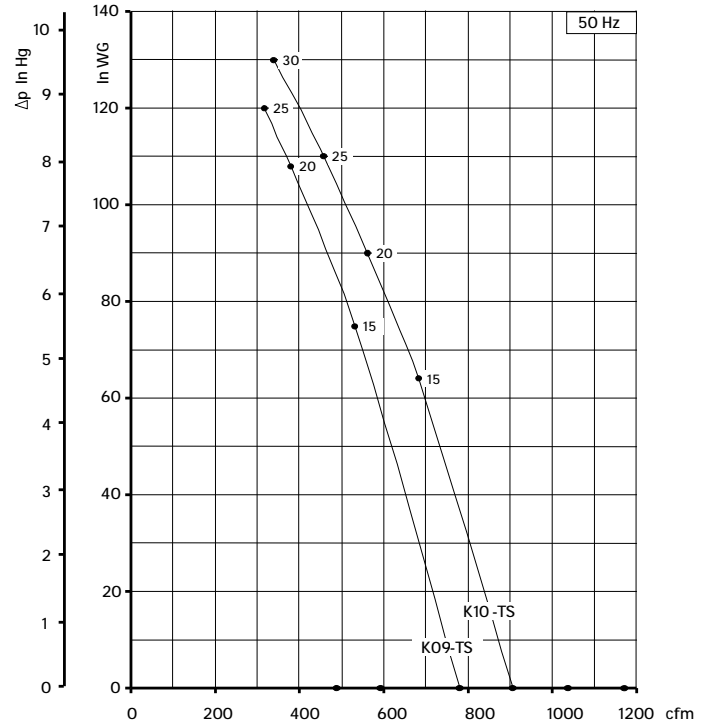
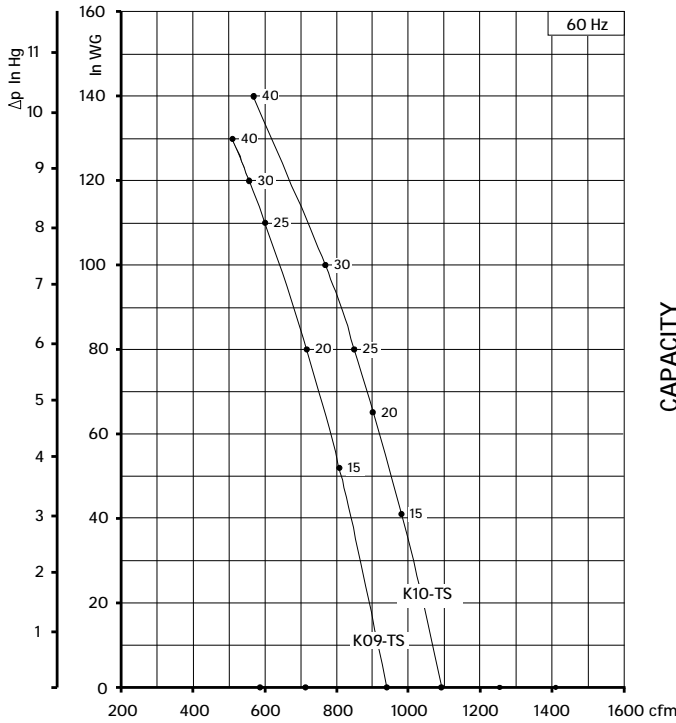

Curves refer to air at 68°F temperature, measured at inlet port and 29.92 In Hg atmospheric backpressure (abs).  
 Values for flow, power consumption and temperature rise: +/-10% tolerance.  
 Data subject to change without notice.



SCL K09 / K10  
MD SERIES - GOR/GVR RANGE  
SN 2150-4 1/2

TECHNICAL CHARACTERISTICS

- Aluminium alloy construction
- Smooth operation
- High efficiency impeller
- Maintenance free
- Mountable in any position

OPTIONS

- Special voltages (IEC 38)
- Surface treatments

ACCESSORIES

- Inlet and/or inline filters
- Additional inlet/outlet silencers
- Safety valves
- Flow converting device
- Optional connectors

GOR Range

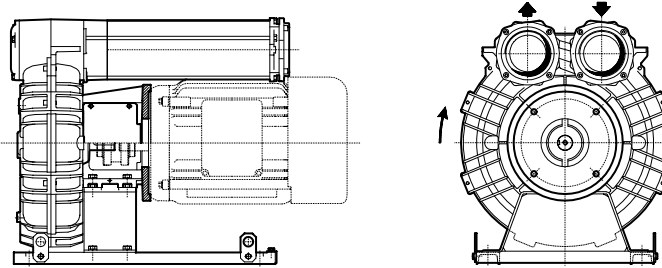

SCL Kxx-MD GOR-C

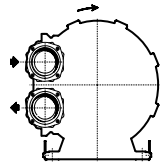

SCL Kxx-MD GOR-A

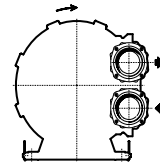

SCL Kxx-MD GOR-B

GVR Range

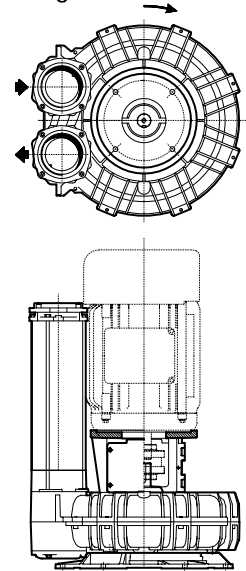

For dimensions, please refer to drw:

GOR range: SI 1918

GVR range: SI 1919

Model	Maximum flow cfm		Installed power Hp	Size	Maximum differential pressure Δp (In Hg)		Noise level Lp dB (A) <sup>(1)</sup>		Weight <sup>(2)</sup> Lbs
	60 Hz 3500 rpm	50 Hz 2900 rpm			60 Hz 3500 rpm	50 Hz 2900 rpm	60 Hz 3500 rpm	50 Hz 2900 rpm	
K09-MD	221	183	5	NEMA 182-4TC	3.7	5.7	76.4	74.4	138.50
			7 1/2	NEMA 182-4TC	8.8	10.5	77.5	75.5	138.50
				NEMA 213-5TC					138.50
			10	NEMA 213-5TC	13.6	13.2	79.0	77.0	138.50
K10-MD	275	228	7 1/2	NEMA 182-4TC	6.3	8.1	80.4	78.4	125.40
				NEMA 213-5TC					152.40
			10	NEMA 213-5TC	10.3	12.1	80.7	78.7	152.40
			15	NEMA 213-5TC	14.7	14.0	81.3	79.3	152.40

(1) Noise measured at 1 m distance with inlet and outlet ports piped, in accordance to ISO 3744.

(2) Value is referred to weight of the machine without electric motor

- For proper use, the blower should be equipped with inlet filter and safety valve; other accessories available on request.
- Ambient temperature from +5° to +104°F.
- Specifications subject to change without notice.



SCL K09 / K10  
MD SERIES - GOR/GVR RANGE  
SN 2150-4 2/2

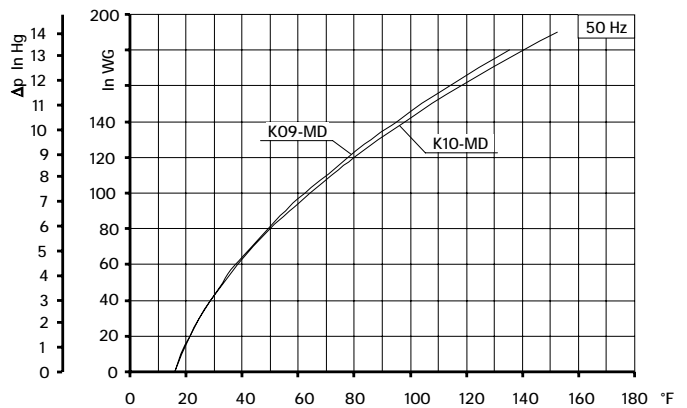
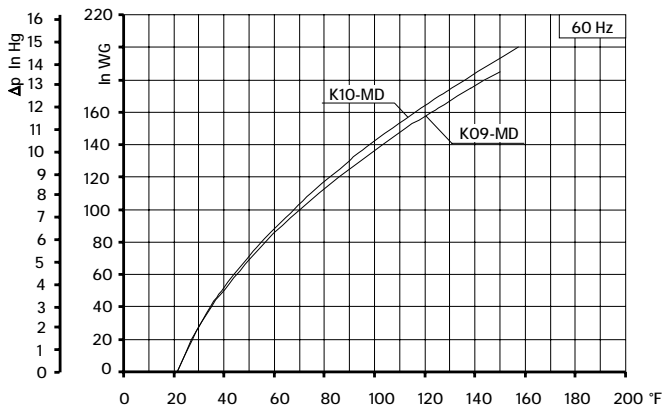
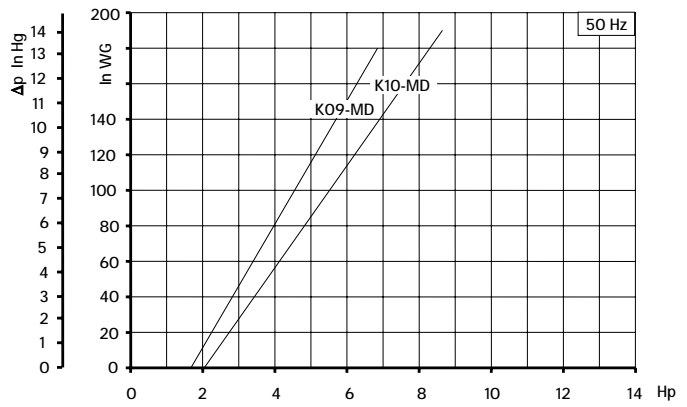
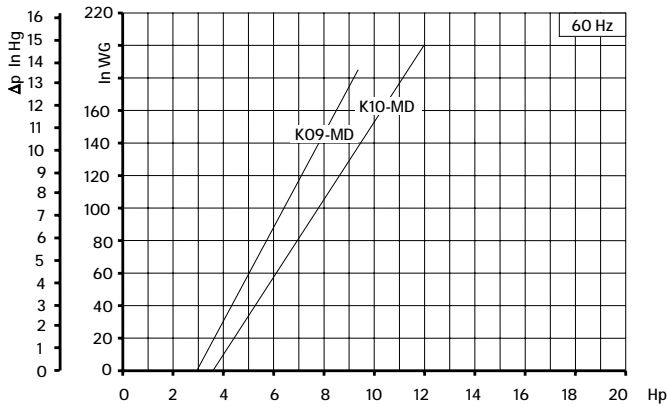
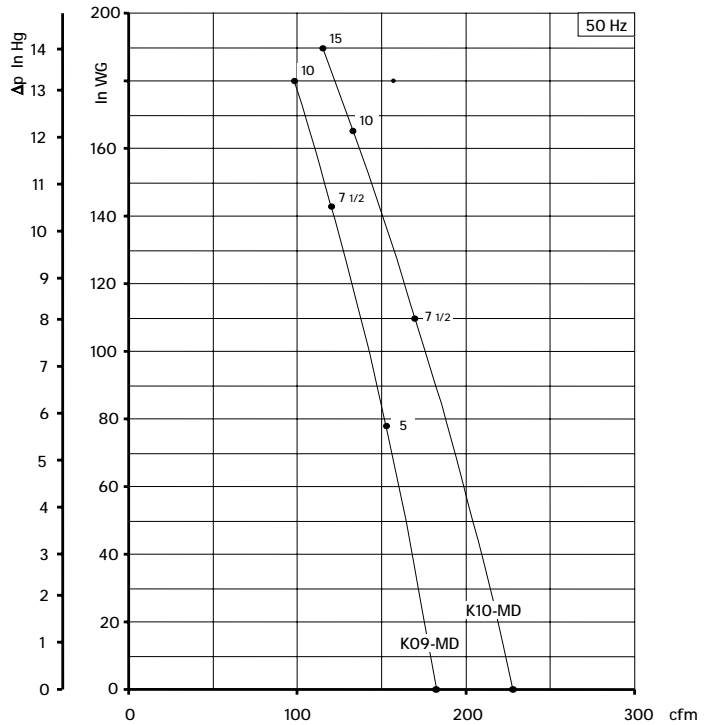
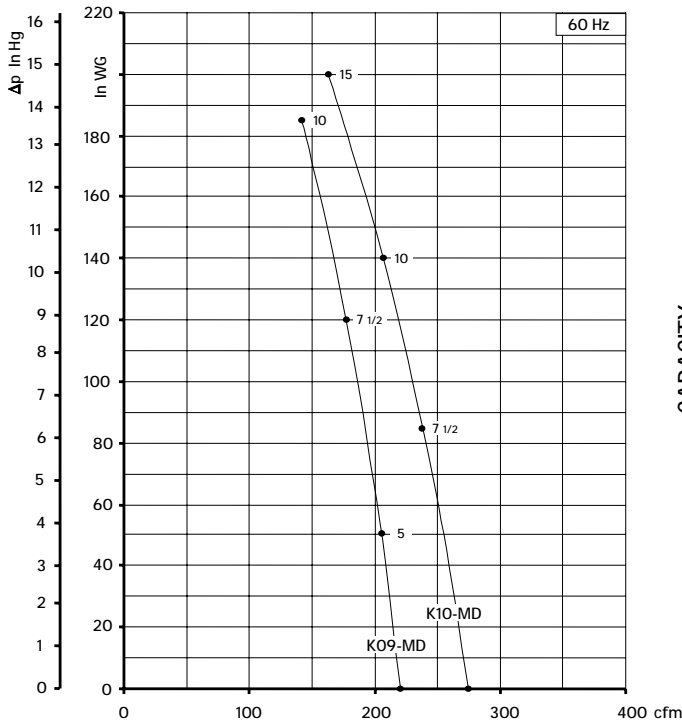

Curves refer to air at 68° F temperature, measured at inlet port and 29.92 In Hg atmospheric backpressure (abs).  
Values for flow, power consumption and temperature rise: +/-10% tolerance.  
Data subject to change without notice.



**TECHNICAL CHARACTERISTICS**

- Aluminium alloy construction
- Smooth operation
- High efficiency impeller
- Maintenance free
- Mountable in any position
- G1/8" female thread on both suction and discharge silencer port flanges

**OPTIONS**

- Special voltages (IEC 38)
- Surface treatments

**ACCESSORIES**

- Inlet and/or inline filters
- Additional inlet/outlet silencers
- Safety valves
- Flow converting device
- Optional connectors

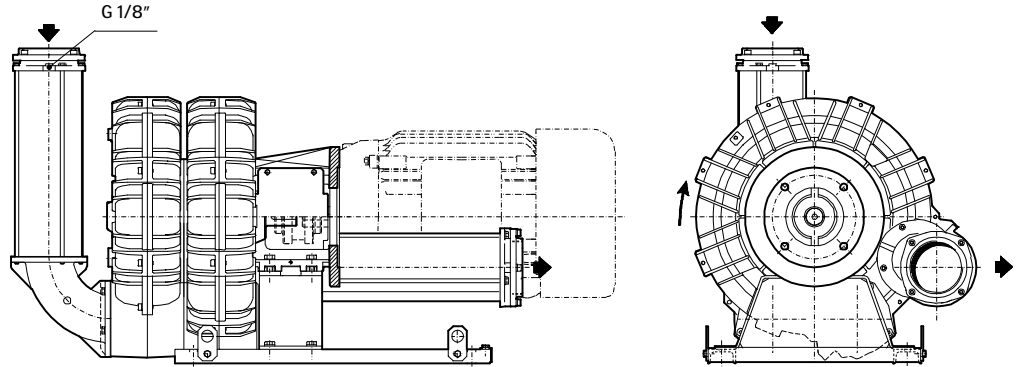

For dimensions, please refer to drw: SI1971

Model	Maximum flow cfm		Installed power Hp	Size	Maximum differential pressure $\Delta p$ (In Hg)		Noise level Lp dB (A) (1)		Weight (2) Lbs
	60 Hz 3500 rpm	50 Hz 2900 rpm			60 Hz 3500 rpm	50 Hz 2900 rpm	60 Hz 3500 rpm	50 Hz 2900 rpm	
	K09-TD	467			387	15	NEMA 213-5TC	7.7	
			NEMA 254-6TC	201.70					
20			NEMA 254-6TC	12.5		82.5	80.5	201.70	
25			NEMA 284-6TSC					13.2	82.8
K10-TD	571	473	15	NEMA 213-5TC	6.3	9.6	85.9	83.9	202.80
				NEMA 254-6TC					209.50
			20	NEMA 254-6TC	13.2	86.2	84.2	209.50	
			25	NEMA 284-6TSC				13.2	86.5

(1) Noise measured at 1 m distance with inlet and outlet ports piped, in accordance to ISO 3744.

(2) Value is referred to weight of the machine without electric motor

- For proper use, the blower should be equipped with inlet filter and safety valve; other accessories available on request.
- Ambient temperature from +5° to +104°F.
- Specifications subject to change without notice.

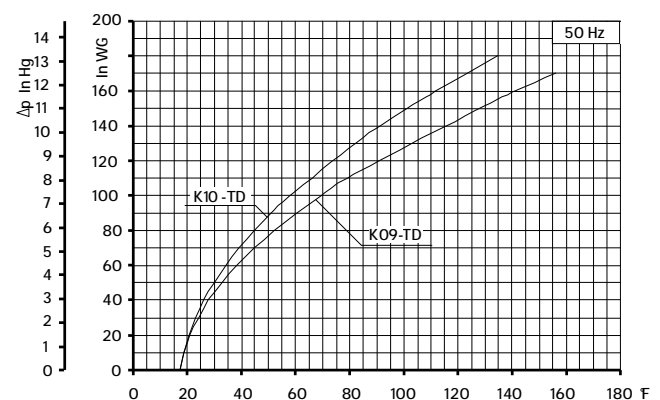
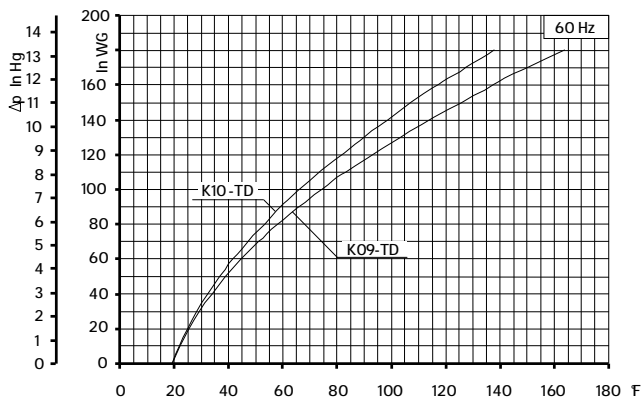
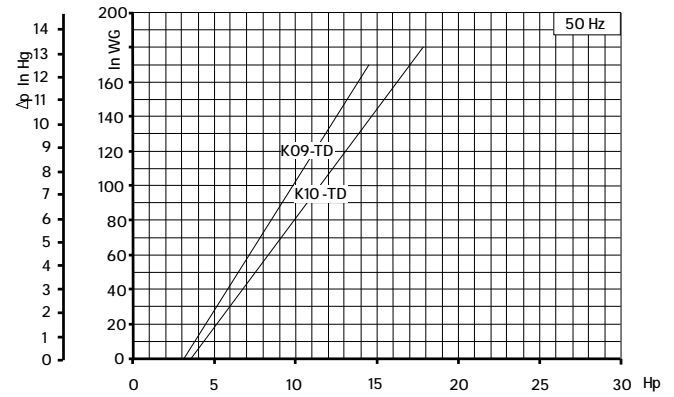
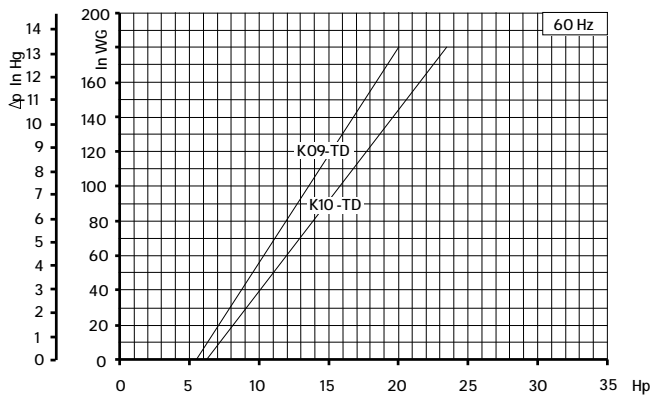
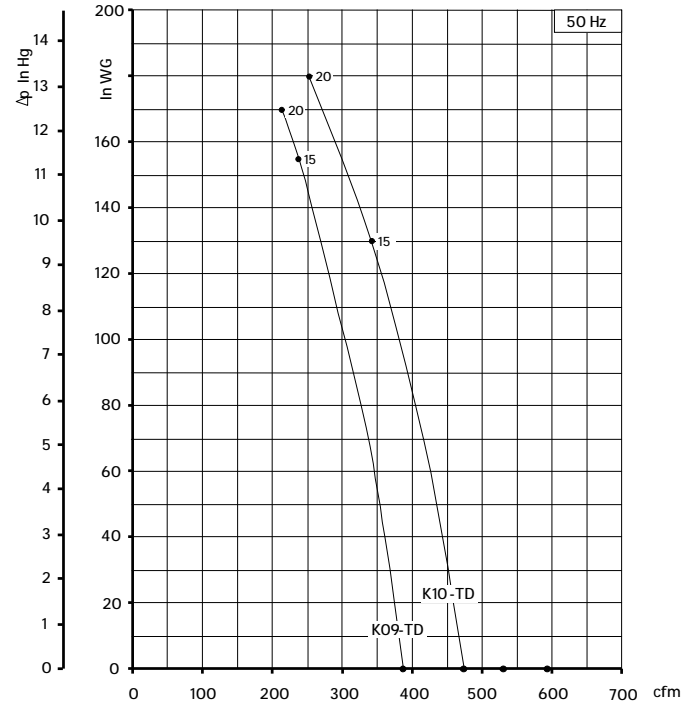
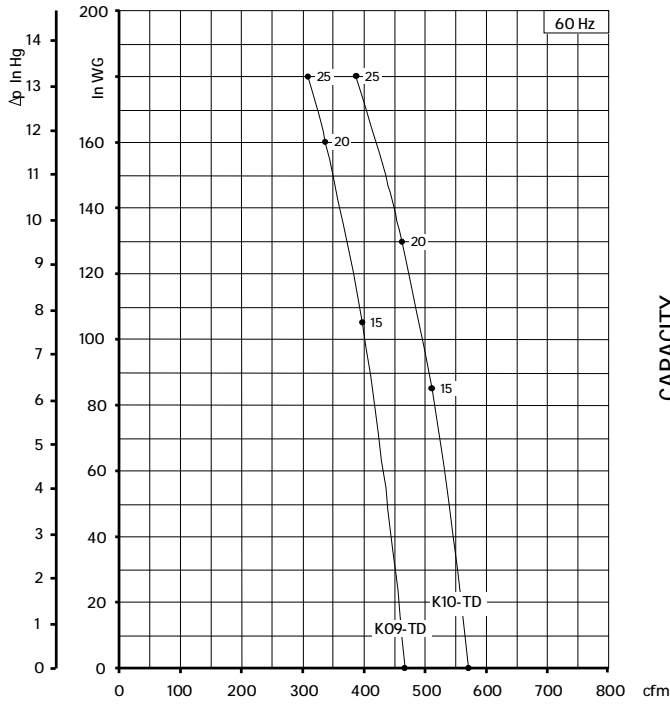

Curves refer to air at 68°F temperature, measured at inlet port and 29.92 In Hg atmospheric backpressure (abs).  
 Values for flow, power consumption and temperature rise: +/-10% tolerance.  
 Data subject to change without notice.



**Evolution Series  
Technical Characteristics**

- Premium efficient motor
- High efficiency impeller
- Mountable in any position
- Maintenance free operation
- TEFC (IP55)

**Optional Features**

- Anodized aluminum components for corrosion resistance
- Increased sealing

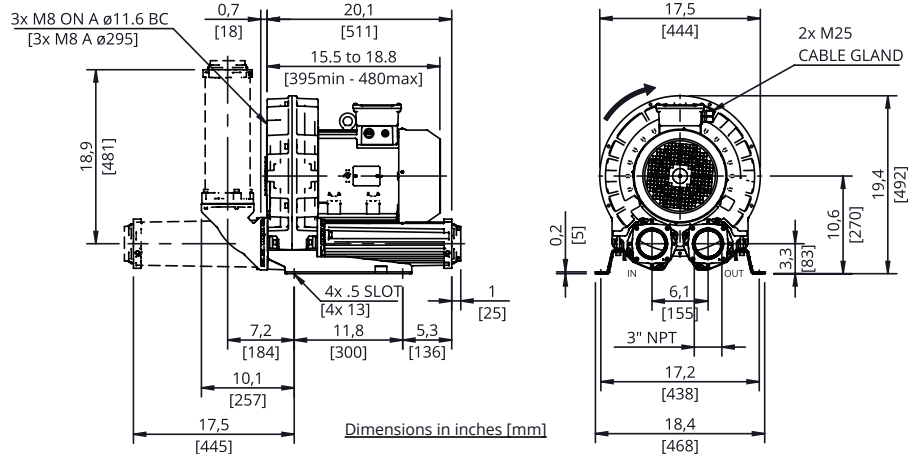

**Technical Specifications**

Model No.	HP	Hz	Open Flow (cfm)	Max Pressure in. H <sub>2</sub> O	Max Vacuum in. H <sub>2</sub> O	Efficiency	Voltage	FLA	Starting Current Ratio <sup>1</sup>	dB(A) <sup>2</sup>	Weight (lb)
SCL e07-MS-4-3	4	60	307	40	40	88.5%	208-230/460	10.9-11.1/5.53	11	75	130.1
		50	254	60	60	87.1%	200/400	12.86/6.38		71	
SCL e07-MS-4-3-575	4	60	307	40	40	88.5%	575	3.94	10.1	75	130.1
SCL e07-MS-5.5-3	5.5	60	307	70	70	88.5%	208-230/460	14.6-15.1/7.55	11.1	75	132.3
		50	254	100	100	88.1%	200/400	17.7/8.86		71	
SCL e07-MS-5.5-3-575	5.5	60	307	70	70	88.5%	575	5.31	10.9	75	132.3
SCL e07-MS-7.5-3	7.5	60	307	110	110	89.5%	208-230/460	19.8-19.5/9.75	13.7	75	174.2
		50	254	140	110	89.2%	200/400	22.2/11.1		71	
SCL e07-MS-7.5-3-575	7.5	60	307	110	110	89.5%	575	7.21	13.5	75	174.2
SCL e07-MS-10-3	10	60	307	160	140	90.2%	208-230/460	26.1-25/12.5	13	75	185.2
		50	254	-	-	90.1%	200/400	28.6/14.3		71	
SCL e07-MS-10-3-575	10	60	307	160	140	90.2%	575	10	12.9	75	185.2

Motors include normally closed thermal protector, 1.15 S.F. (60 Hz), tropicalized windings, Class F (B) insulation, and are suitable for use with a VFD (Contact FPZ for pneumatic and speed limits when used with a VFD).

<sup>1</sup>Starting current ratio x fla = starting current

<sup>2</sup>Noise level measured at a distance of 1 m with inlet and outlet ports piped in accordance to ISO 3744

Data is subject to change without notice.

**Recommended Accessories**

Description	Pressure Safety Valve	Vacuum Safety Valve	Pressure Filter	Vacuum Filter	Check Valve
Part Number	VRL6 (7.5 hp & 10 hp) <sup>3</sup>	VRL6 (5.5hp - 10 hp)	FS-231P-300	CT-235P-300C	CV30
	VRL8 (4 hp & 5.5 hp) <sup>3</sup>	VRL8 (4 hp)			

<sup>3</sup>Valve selections are based on 60 Hz and standard air. Valves are supplied uncalibrated. Safety valves are easy to calibrate, but can be ordered with factory calibration.



### PRESSURE

### VACUUM

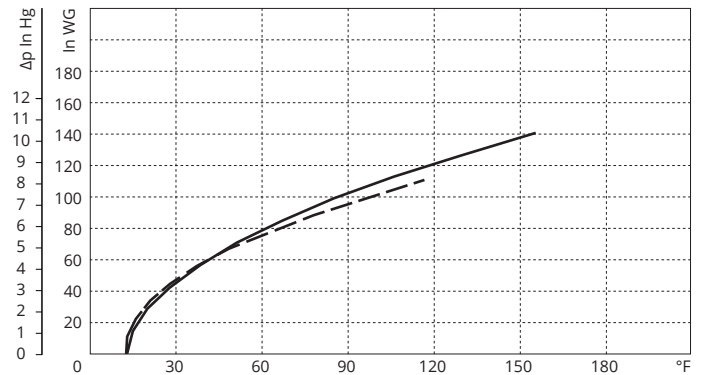
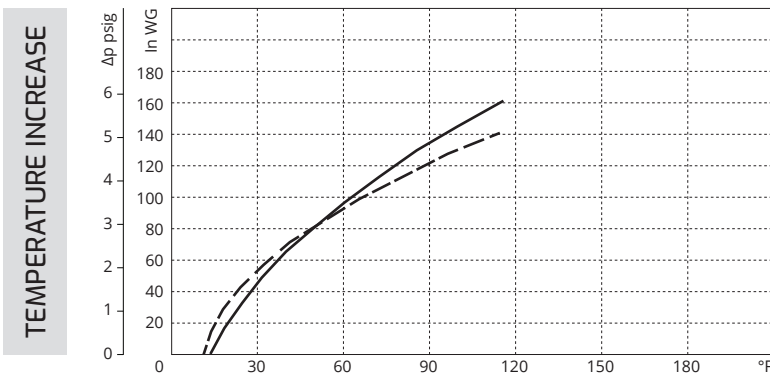
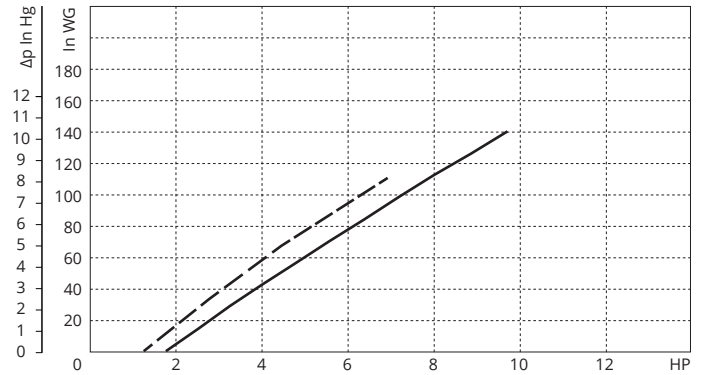
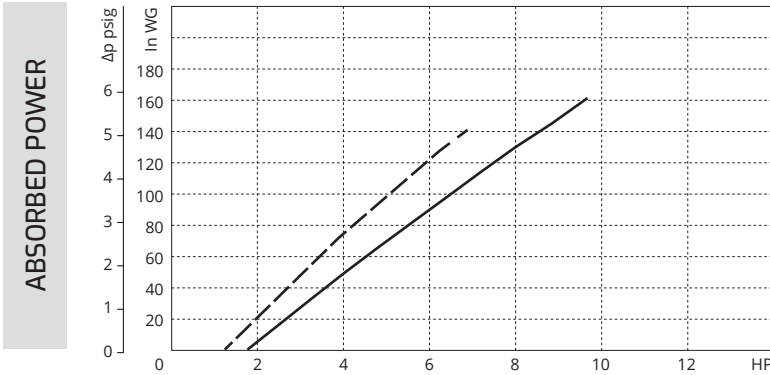
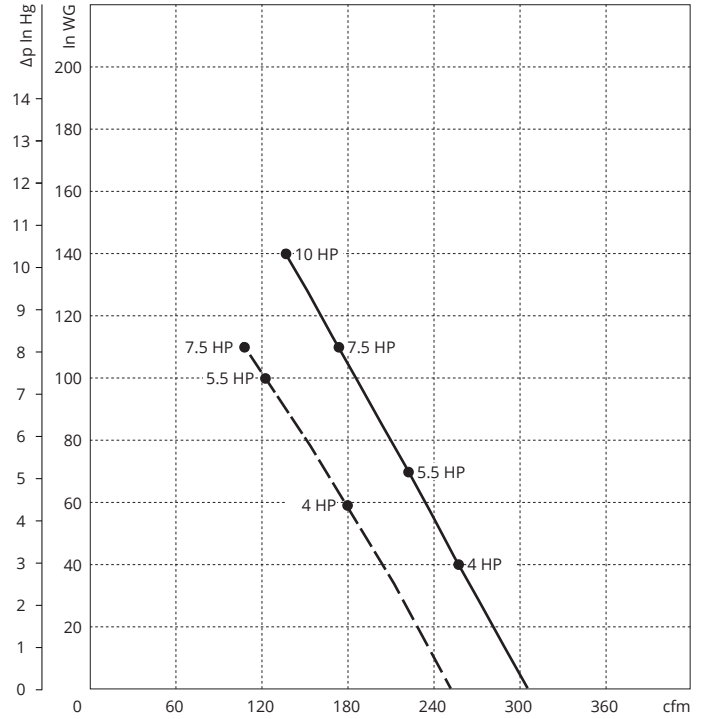
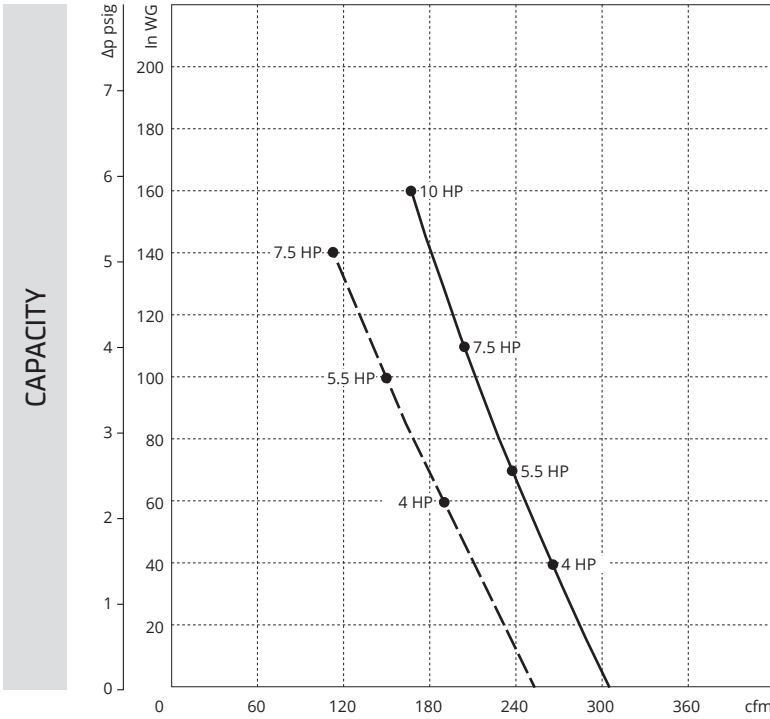

Curves refer to air at 68°F temperature and 29.92 In Hg atmospheric pressure (abs) measured at inlet port.  
 Values for flow, power consumption and temperature rise: +/-10% tolerance.  
 Data subject to change without notice.

**KEY**    --- 50 Hz  
 ——— 60 Hz





**Evolution Series  
Technical Characteristics**

- Premium efficient motor
- High efficiency impeller
- Mountable in any position
- Maintenance free operation
- TEFC (IP55)

**Optional Features**

- Anodized aluminum components for corrosion resistance
- Increased sealing

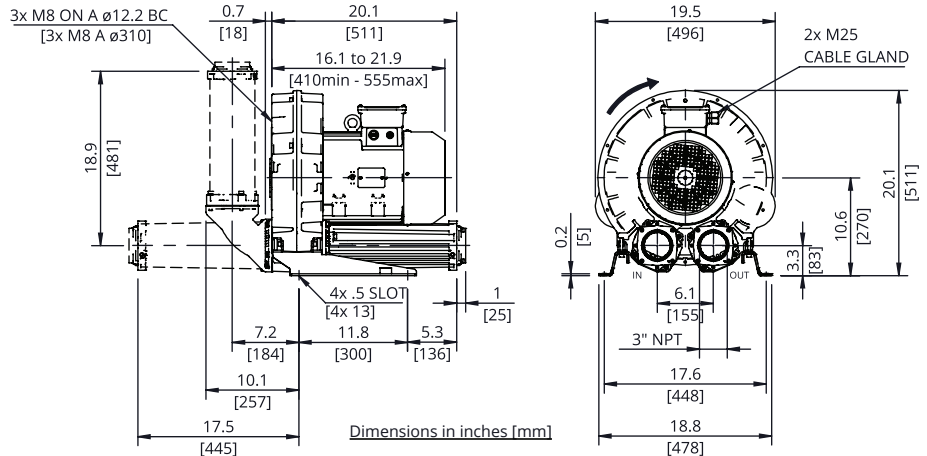

**Technical Specifications**

Model No.	HP	Hz	Open Flow (cfm)	Max Pressure in. H <sub>2</sub> O	Max Vacuum in. H <sub>2</sub> O	Efficiency	Voltage	FLA	Starting Current Ratio <sup>1</sup>	dB(A) <sup>2</sup>	Weight (lb)
SCL e08-MS-5.5-3	5.5	60	394	40	40	88.5%	208-230/460	14.6-15.1/7.55	11.1	76.8	143.3
		50	331	70	70	88.1%	200/400	17.7/8.86		72.1	
SCL e08-MS-5.5-3-575	5.5	60	394	40	40	88.5%	575	5.31	10.9	76.8	143.3
SCL e08-MS-7.5-3	7.5	60	394	70	80	89.5%	208-230/460	19.8-19.5/9.75	13.7	76.8	167.6
		50	331	110	110	89.2%	200/400	22.2/11.1		72.1	
SCL e08-MS-7.5-3-575	7.5	60	394	70	80	89.5%	575	7.21	13.5	76.8	167.6
SCL e08-MS-10-3	10	60	394	110	110	90.2%	208-230/460	26.1-25/12.5	13	76.8	194.0
		50	331	150	120	90.1%	200/400	28.6/14.3		72.1	
SCL e08-MS-10-3-575	10	60	394	110	110	90.2%	575	10	12.9	76.8	194.0
SCL e08-MS-15-3	15	60	394	170	130	91.0%	208-230/460	38.2-37.3/18.7	12.5	76.8	207.3
		50	331	170	120	91.0%	200/400	43.4 / 21.7		72.1	
SCL e08-MS-15-3-575	15	60	394	170	130	91.0%	575	13.9	11	76.8	207.3

Motors include normally closed thermal protector, 1.15 S.F. (60 Hz), tropicalized windings, Class F (B) insulation, and are suitable for use with a VFD (Contact FPZ for pneumatic and speed limits when used with a VFD).

<sup>1</sup>Starting current ratio x fla = starting current

<sup>2</sup>Noise level measured at a distance of 1 m with inlet and outlet ports piped in accordance to ISO 3744

Data is subject to change without notice.

**Recommended Accessories**

Description	Pressure Safety Valve	Vacuum Safety Valve	Pressure Filter	Vacuum Filter	Check Valve
Part Number	VRL6 (10 HP & 15 HP) <sup>3</sup>	VRL6 (15 HP)	FS-235P-300	CT-235P-300C	CV30
	VRL8 (5.5 HP & 7.5 HP) <sup>3</sup>	VRL8 (5.5 HP-10 HP)			

<sup>3</sup>Valve selections are based on 60 Hz and standard air. Valves are supplied uncalibrated. Safety valves are easy to calibrate, but can be ordered with factory calibration.





**PRESSURE**

**VACUUM**

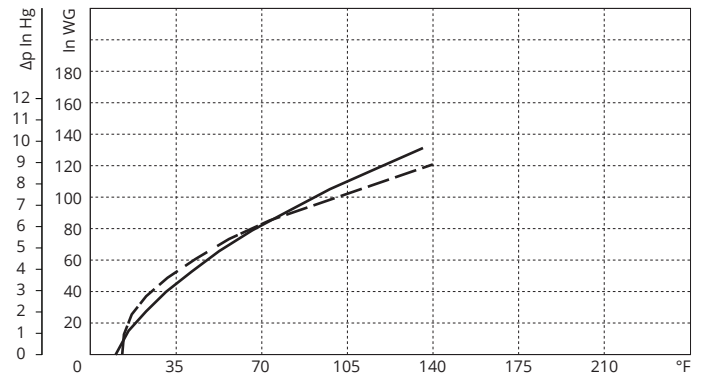
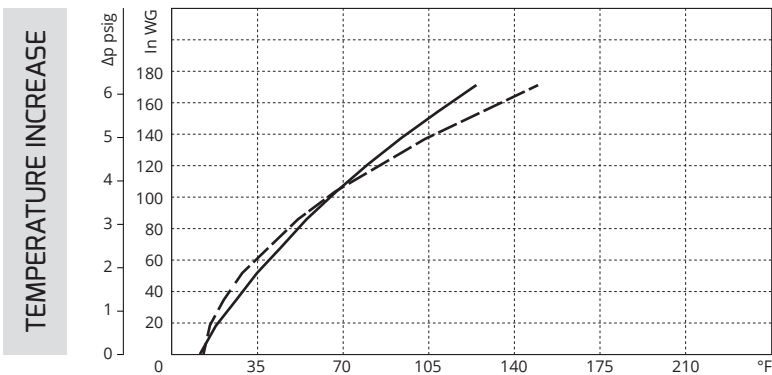
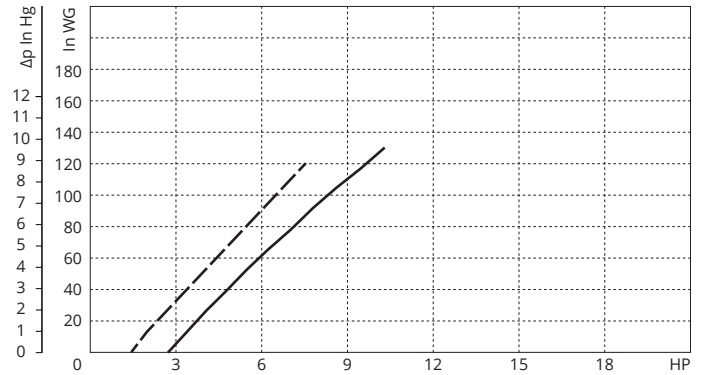
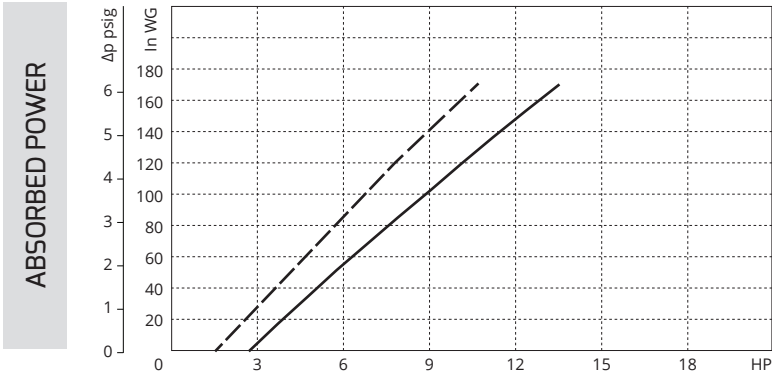
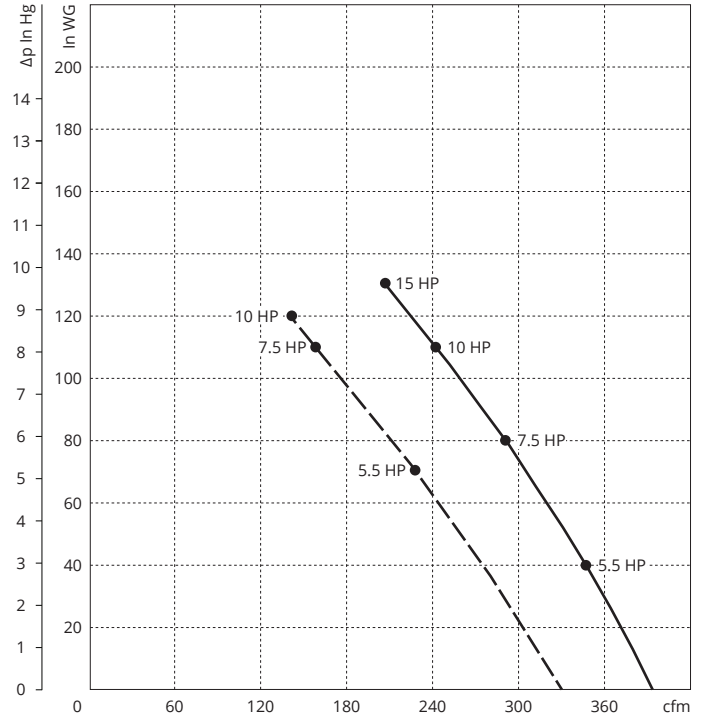
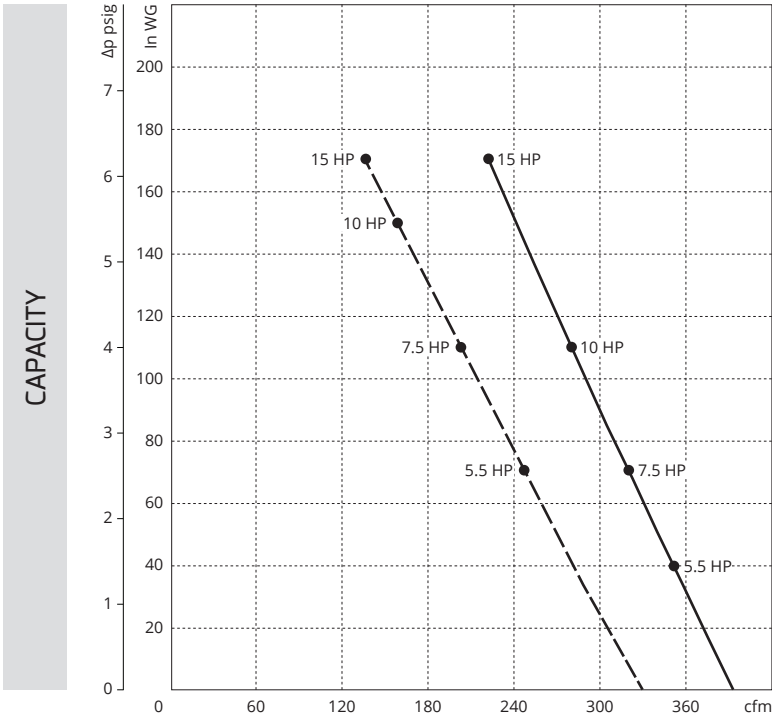

Curves refer to air at 68°F temperature and 29.92 In Hg atmospheric pressure (abs) measured at inlet port.  
 Values for flow, power consumption and temperature rise: +/-10% tolerance.  
 Data subject to change without notice.

**KEY**    --- 50 Hz  
           — 60 Hz



**Evolution Series  
Technical Characteristics**

- Premium efficient motor
- High efficiency impeller
- Mountable in any position
- Maintenance free operation
- TEFC (IP55)

**Optional Features**

- Anodized aluminum components for corrosion resistance
- Increased sealing

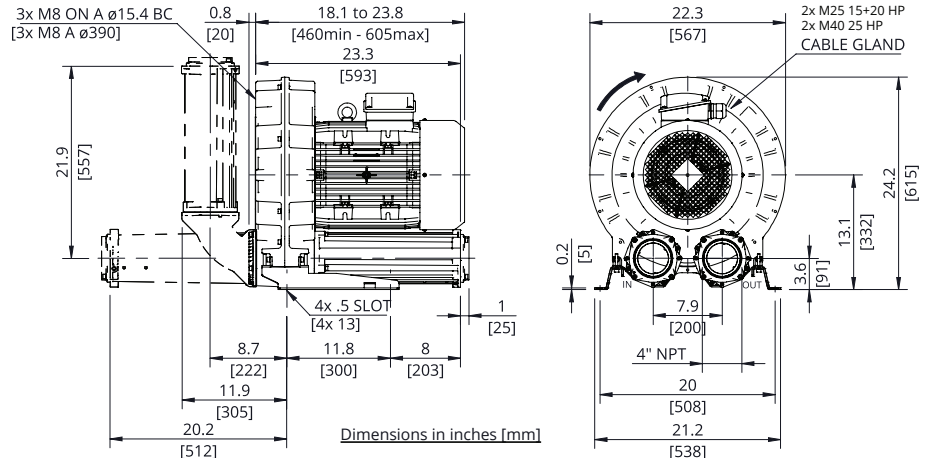

**Technical Specifications**

Model No.	HP	Hz	Open Flow (cfm)	Max Pressure in. H <sub>2</sub> O	Max Vacuum in. H <sub>2</sub> O	Efficiency	Voltage	FLA	Starting Current Ratio <sup>1</sup>	dB(A) <sup>2</sup>	Weight (lb)
SCL e11-MS-15-3	15	60	639	80	90	91.0%	208-230/460	38.2-37.3/18.7	12.5	83	248.0
		50	553	110	120	91.0%	200/400	43.4/21.7		78	
SCL e11-MS-15-3-575	15	60	639	80	90	91.0%	575	13.9	11	83	248.0
SCL e11-MS-20-3	20	60	639	120	150	91.7%	208-230/460	47.0 / 23.5	9.7	83	273.4
		50	553	160	140	91.9%	200/400	52.4 / 26.2		78	
SCL e11-MS-20-3-575	20	60	639	120	150	91.0%	575	18.8	9.8	83	273.4
SCL e11-MS-25-3	25	60	639	150	-	91.7%	208-230/460	62 / 31	12.5	83	352.7
		50	553	180	-	92.4%	200/400	69 / 34.5		78	
SCL e11-MS-25-3-575	25	60	639	150	-	91.7%	575	24.8	12.5	83	352.7

Motors include normally closed thermal protector, 1.15 S.F. (60 Hz), tropicalized windings, Class F (B) insulation, and are suitable for use with a VFD (Contact FPZ for pneumatic and speed limits when used with a VFD).

<sup>1</sup>Starting current ratio x fla = starting current

<sup>2</sup>Noise level measured at a distance of 1 m with inlet and outlet ports piped in accordance to ISO 3744

Data is subject to change without notice.

**Recommended Accessories**

Description	Pressure Safety Valve	Vacuum Safety Valve	Pressure Filter	Vacuum Filter	Check Valve
Part Number	VRL9 (15 HP) <sup>3</sup>	VRL9 (15 HP) <sup>3</sup>	FS-245P-400	CSL-2541-400I	CV40
	VRL8 (20 HP & 25 HP) <sup>3</sup>	VRL8 (20 HP) <sup>3</sup>			

<sup>3</sup>Valve selections are based on 60 Hz and standard air. Valves are supplied uncalibrated. Safety valves are easy to calibrate, but can be ordered with factory calibration.



### PRESSURE

### VACUUM

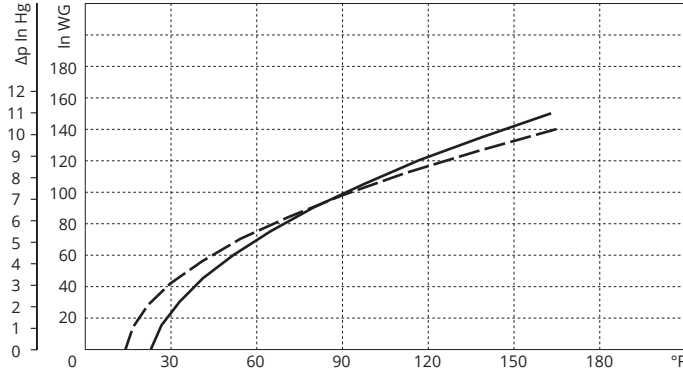
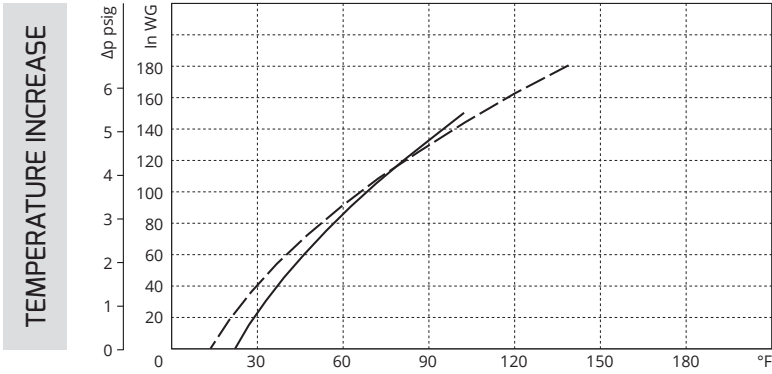
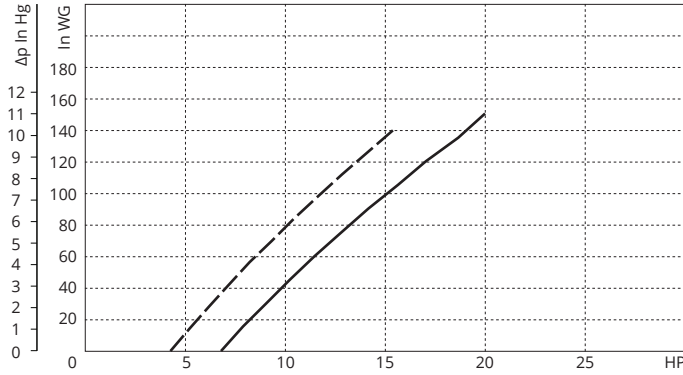
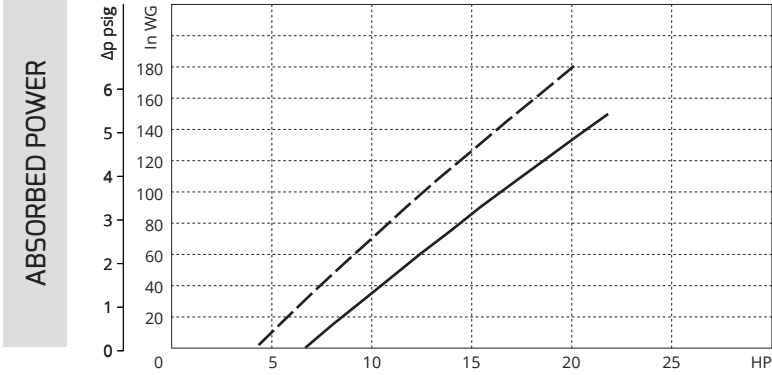
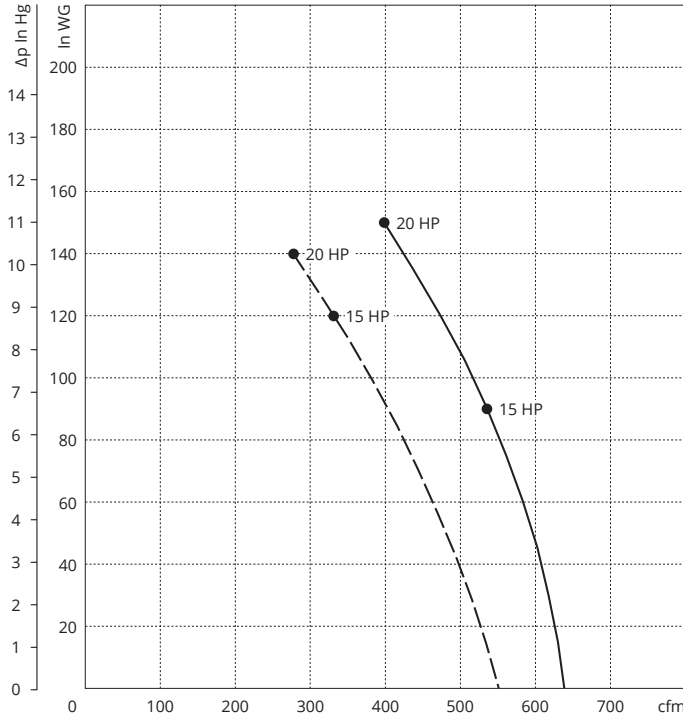
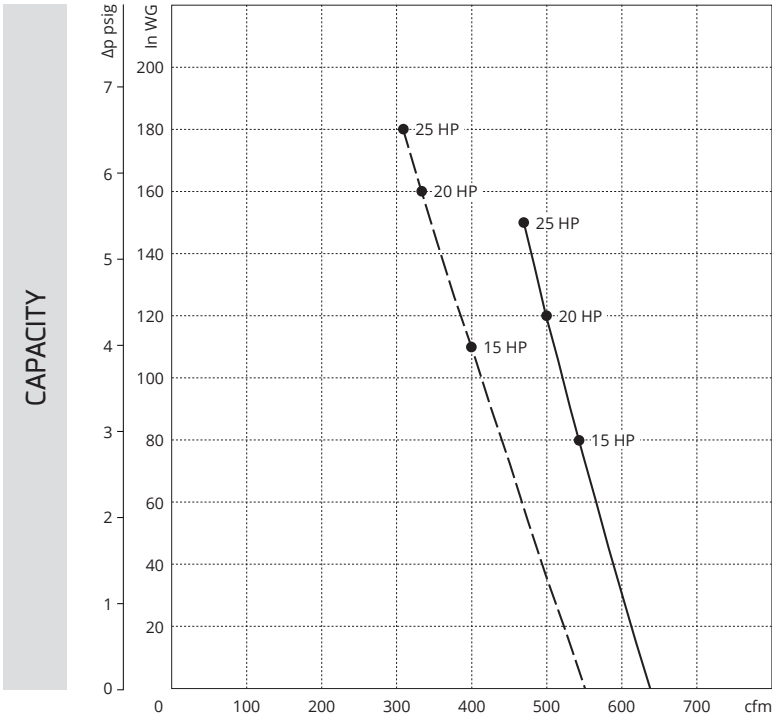

Curves refer to air at 68°F temperature and 29.92 In Hg atmospheric pressure (abs) measured at inlet port.  
 Values for flow, power consumption and temperature rise: +/-10% tolerance.  
 Data subject to change without notice.

**KEY**    --- 50 Hz  
 ——— 60 Hz



**Evolution Series Technical Characteristics**

- Premium efficient motor
- High efficiency impeller
- Mountable in any position
- Maintenance free operation
- TEFC (IP55)

**Optional Features**

- Anodized aluminum components for corrosion resistance
- Increased sealing

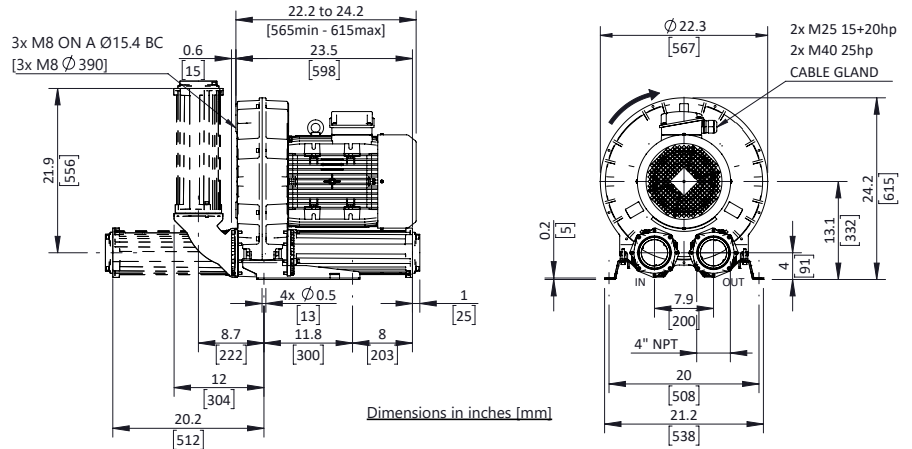

**Technical Specifications**

Model No.	HP	Hz	Open Flow (cfm)	Max Pressure in. H <sub>2</sub> O	Max Vacuum in. H <sub>2</sub> O	Efficiency	Voltage	FLA	Starting Current Ratio <sup>1</sup>	dB(A) <sup>2</sup>	Weight (lb)
SCL e12-MS-15-3	15	60	722	50	60	91.0%	208-230/460	38.2-37.3/18.7	12.5	84	250.2
		50	603	90	100	91.0%	200/400	43.4/21.7		79	
SCL e12-M-15-3-575	15	60	722	50	60	91.0%	575	13.9	11	84	250.2
SCL e12-MS-20-3	20	60	722	90	110	91.7%	208-230/460	47.0 / 23.5	9.7	84	275.6
		50	603	140	130	91.9%	200/400	52.4 / 26.2		79	
SCL e12-MS-20-3-575	20	60	722	90	110	91.0%	575	18.8	9.8	84	275.6
SCL e12-MS-25-3	25	60	722	130	140	91.7%	208-230/460	62 / 31	12.5	84	354.9
		50	603	180	-	92.4%	200/400	69 / 34.5		79	
SCL e12-MS-25-3-575	25	60	722	130	140	91.7%	575	24.8	12.5	84	354.9

Motors include normally closed thermal protector, 1.15 S.F. (60 Hz), tropicalized windings, Class F (B) insulation, and are suitable for use with a VFD (Contact FPZ for pneumatic and speed limits when used with a VFD).

<sup>1</sup>Starting current ratio x fla = starting current

<sup>2</sup>Noise level measured at a distance of 1 m with inlet and outlet ports piped in accordance to ISO 3744

Data is subject to change without notice.

**Recommended Accessories**

Description	Pressure Safety Valve	Vacuum Safety Valve	Pressure Filter	Vacuum Filter	Check Valve
Part Number	VRL9 (15 HP & 20 HP) <sup>3</sup>	VRL9 (15 HP & 20 HP) <sup>3</sup>	FS-245P-400	CSL-2541-400I	CV40
	VRL8 (25 HP) <sup>3</sup>	VRL8 (25 HP) <sup>3</sup>			

<sup>3</sup>Valve selections are based on 60 Hz and standard air. Valves are supplied uncalibrated. Safety valves are easy to calibrate, but can be ordered with factory calibration.



### PRESSURE

### VACUUM

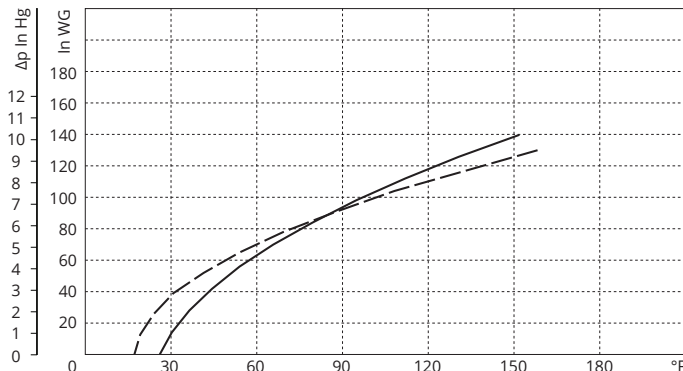
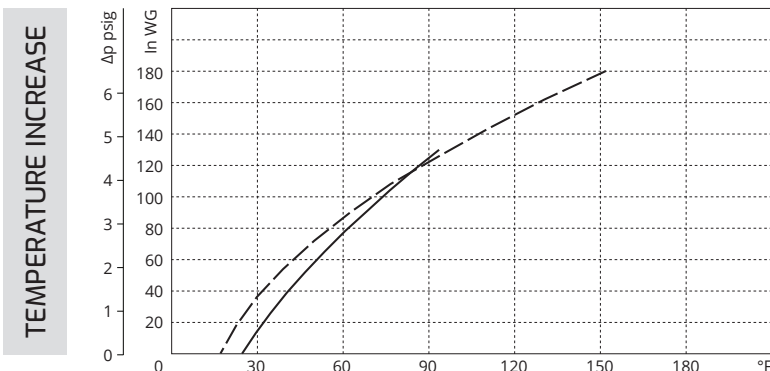
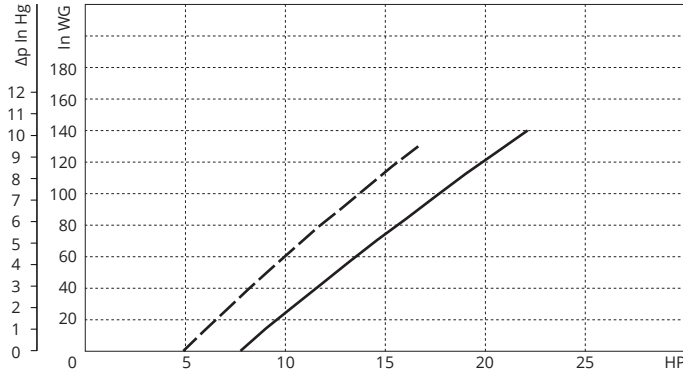
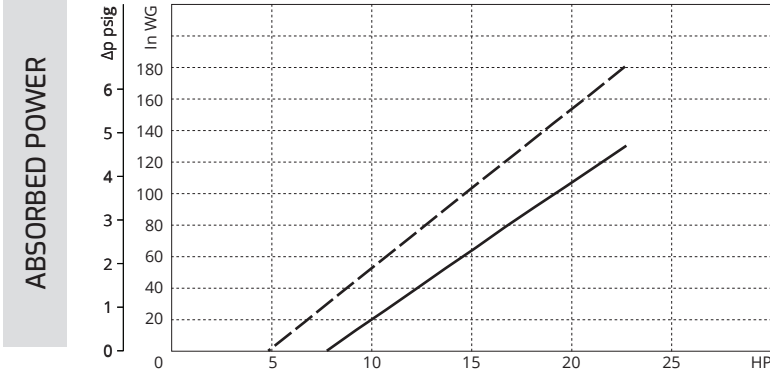
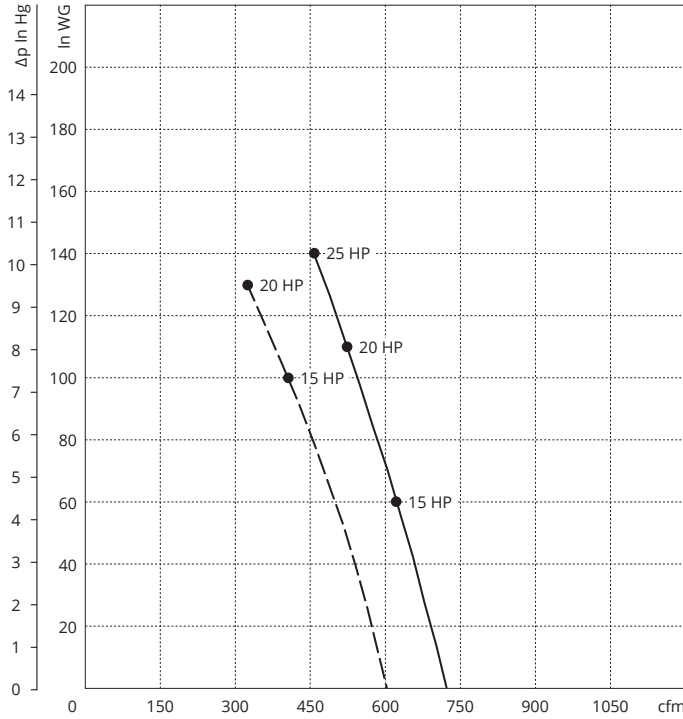
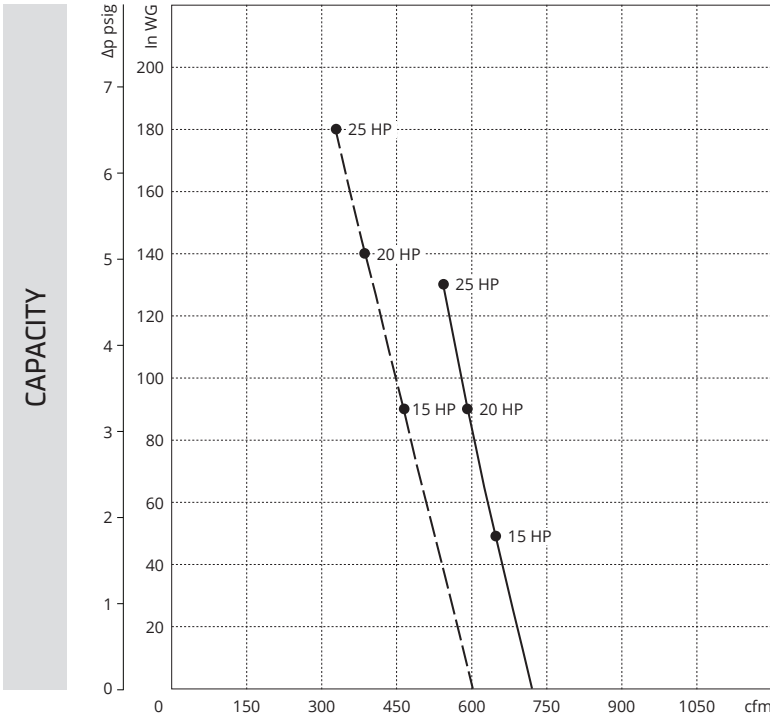

Curves refer to air at 68°F temperature and 29.92 In Hg atmospheric pressure (abs) measured at inlet port.  
 Values for flow, power consumption and temperature rise: +/-10% tolerance.  
 Data subject to change without notice.

**KEY**    --- 50 Hz  
 ——— 60 Hz



**Evolution Series  
Technical Characteristics**

- Premium efficient motor
- High efficiency impeller
- Mountable in any position
- Maintenance free operation
- TEFC (IP55)

**Optional Features**

- Anodized aluminum components for corrosion resistance
- Increased sealing

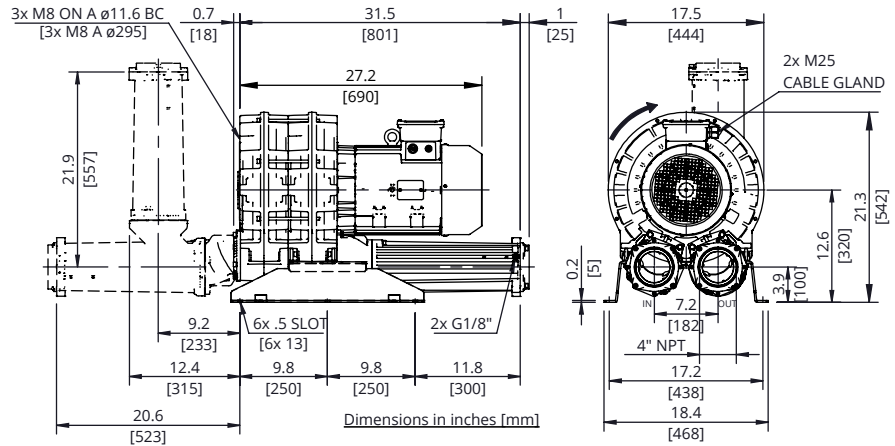

**Technical Specifications**

Model No.	HP	Hz	Open Flow (cfm)	Max Pressure in. H <sub>2</sub> O	Max Vacuum in. H <sub>2</sub> O	Efficiency	Voltage	FLA	Starting Current Ratio <sup>1</sup>	dB(A) <sup>2</sup>	Weight (lb)
SCL e07-TS-7.5-3	7.5	60	582	30	30	89.5%	208-230/460	19.8-19.5/9.75	13.7	77.0	249.1
		50	491	60	60	89.2%	200/400	22.2/11.1		73.0	
SCL e07-TS-7.5-3-575	7.5	60	582	50	30	89.5%	575	7.21	13.5	77.0	249.1
SCL e07-TS-10-3	10	60	582	50	60	90.2%	208-230/460	26.1-25/12.5	13	77.0	260.1
		50	491	80	90	90.1%	200/400	28.6/14.3		73.0	
SCL e07-TS-10-3-575	10	60	582	50	60	90.2%	575	10	12.9	77.0	260.1
SCL e07-TS-15-3	15	60	582	100	110	91.0%	208-230/460	38.2-37.3/18.7	12.5	77.0	273.4
		50	491	130	-	91.0%	200/400	43.4 / 21.7		73.0	
SCL e07-TS-15-3-575	15	60	582	100	110	91.0%	575	13.9	11	77.0	273.4

Motors include normally closed thermal protector, 1.15 S.F. (60 Hz), tropicalized windings, Class F (B) insulation, and are suitable for use with a VFD (Contact FPZ for pneumatic and speed limits when used with a VFD).

<sup>1</sup>Starting current ratio x fla = starting current

<sup>2</sup>Noise level measured at a distance of 1 m with inlet and outlet ports piped in accordance to ISO 3744

Data is subject to change without notice.

**Recommended Accessories**

Description	Pressure Safety Valve	Vacuum Safety Valve	Pressure Filter	Vacuum Filter	Check Valve
Part Number	VRL8 (15 HP) <sup>3</sup>	VRL8 (15 HP) <sup>3</sup>	FS-245P-400	CSL-2541P-400I	CV40
	VRL9 (5.5 HP - 10 HP) <sup>3</sup>	VRL9 (5.5 HP-10 HP) <sup>3</sup>			

<sup>3</sup>Valve selections are based on 60 Hz and standard air. Valves are supplied uncalibrated. Safety valves are easy to calibrate, but can be ordered with factory calibration.





**PRESSURE**

**VACUUM**

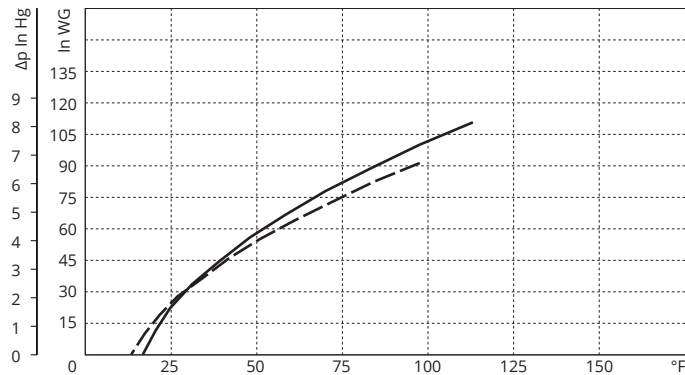
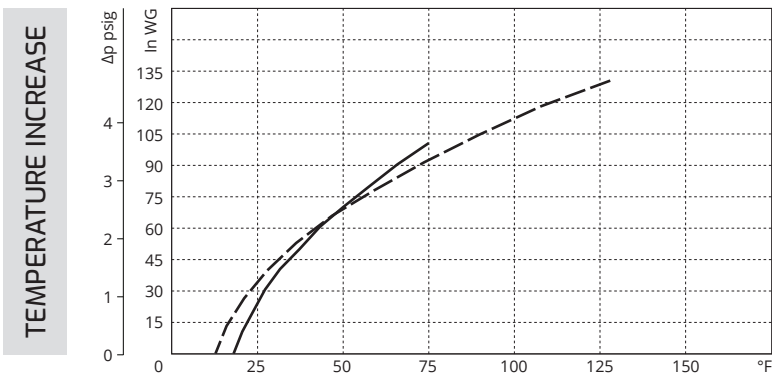
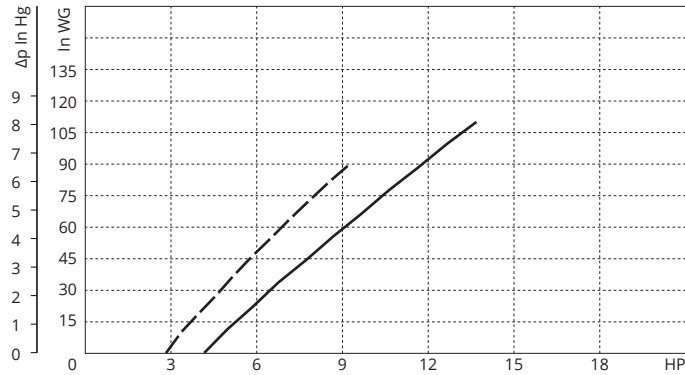
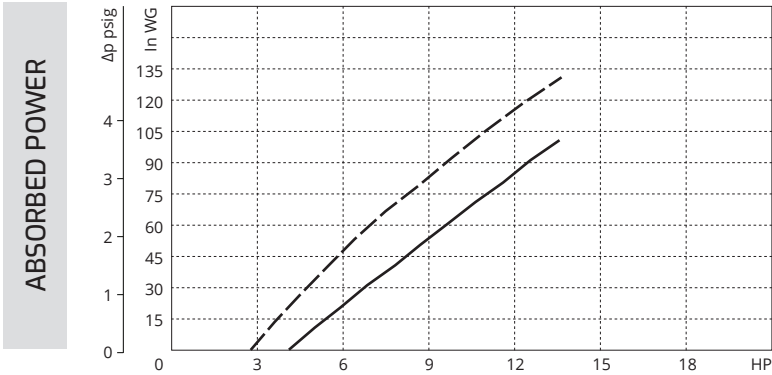
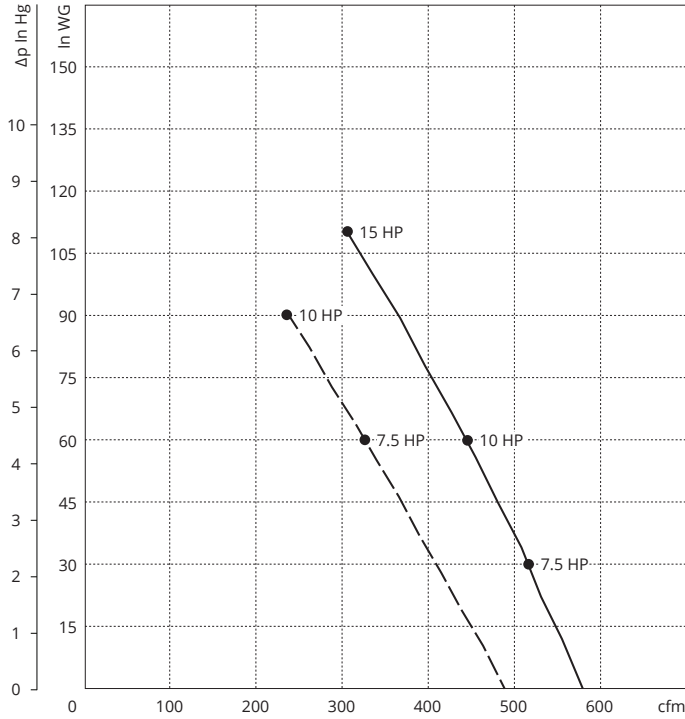
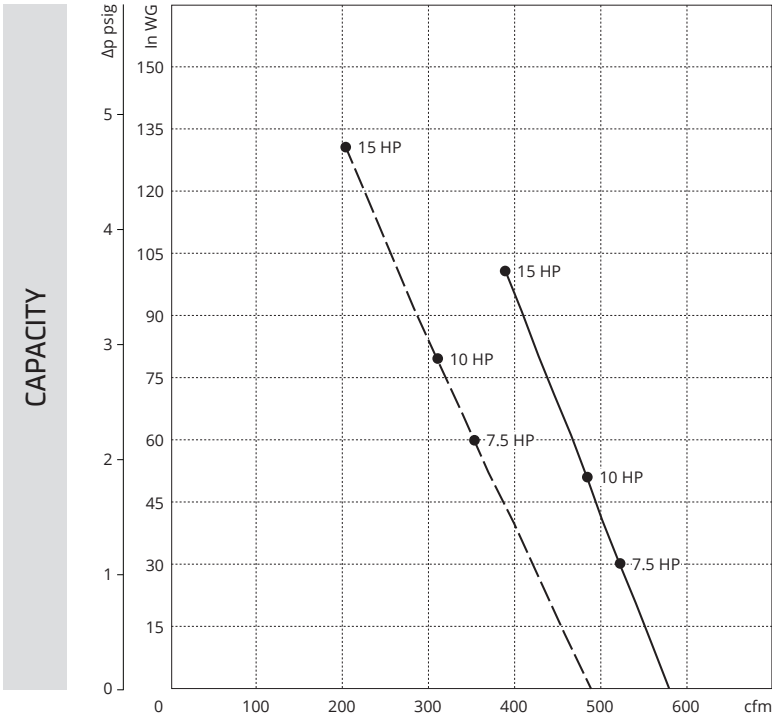

Curves refer to air at 68°F temperature and 29.92 In Hg atmospheric pressure (abs) measured at inlet port. Values for flow, power consumption and temperature rise: +/-10% tolerance. Data subject to change without notice.

**KEY**    --- 50 Hz  
          — 60 Hz



**e08-TS**

**Evolution Series  
Technical Characteristics**

- Premium efficient motor
- High efficiency impeller
- Mountable in any position
- Maintenance free operation
- TEFC (IP55)

**Optional Features**

- Anodized aluminum components for corrosion resistance
- Increased sealing

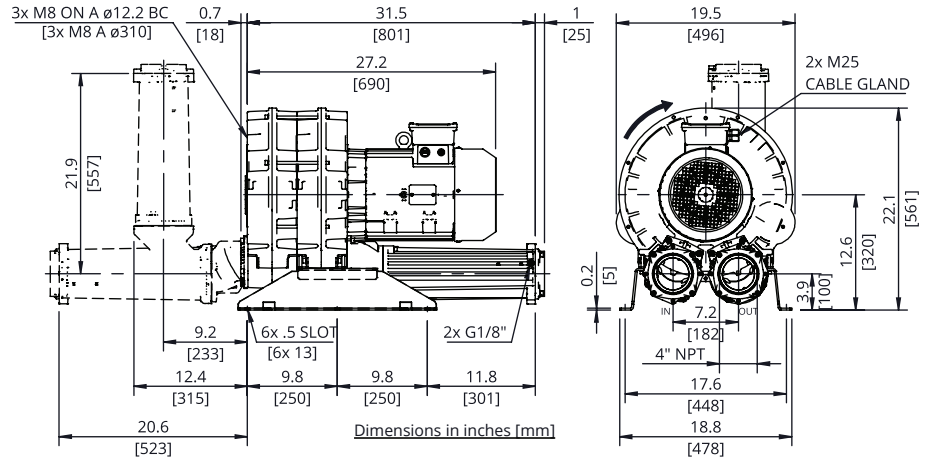

**Technical Specifications**

Model No.	HP	Hz	Open Flow (cfm)	Max Pressure in. H <sub>2</sub> O	Max Vacuum in. H <sub>2</sub> O	Efficiency	Voltage	FLA	Starting Current Ratio <sup>1</sup>	dB(A) <sup>2</sup>	Weight (lb)
<b>SCL e08-TS-15-3</b>	15	60	712	60	60	91.0%	208-230/460	38.2-37.3/18.7	12.5	83.3	293.2
		50	593	90	90	91.2%	200/400	43.4/21.7		81.3	
<b>SCL e08-TS-15-3-575</b>	15	60	712	60	60	91.0%	575	13.9	11	83.3	293.2

Motors include normally closed thermal protector, 1.15 S.F. (60 Hz), tropicalized, Class F (B) insulation, and are suitable for use with VFD (Contact FPZ for pneumatic and speed limits when used with a VFD).

<sup>1</sup>Starting current ratio x fla = starting current

<sup>2</sup>Noise level measured at a distance of 1 m with inlet and outlet ports piped in accordance to ISO 3744

Data is subject to change without notice.

**Recommended Accessories**

Description	Pressure Safety Valve	Vacuum Safety Valve	Pressure Filter	Vacuum Filter	Check Valve
Part Number	VRL9 <sup>3</sup>	VRL9 <sup>3</sup>	FS-245P-400	CSL-2541-400I	CV40

<sup>3</sup>Valve selections are based on 60 Hz and standard air. Valves are supplied uncalibrated. Safety valves are easy to calibrate, but can be ordered with factory calibration.





**PRESSURE**

**VACUUM**

CAPACITY

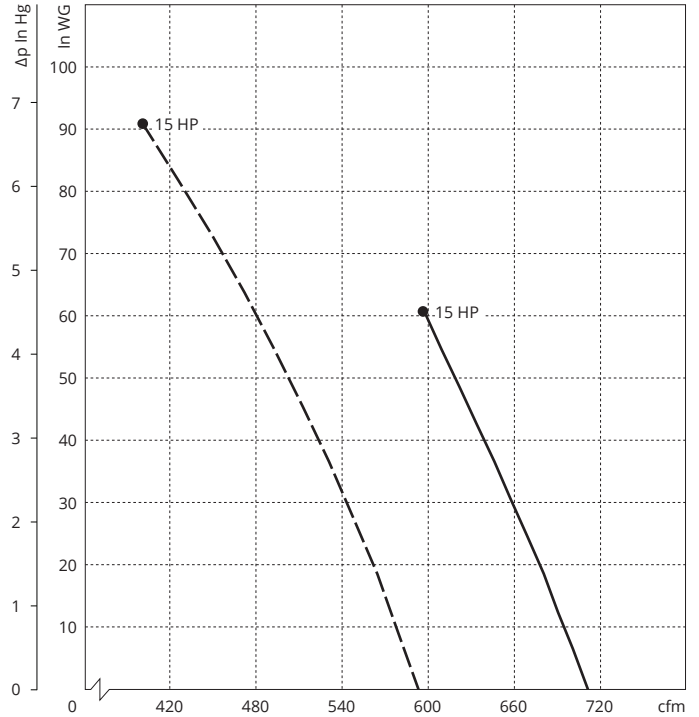
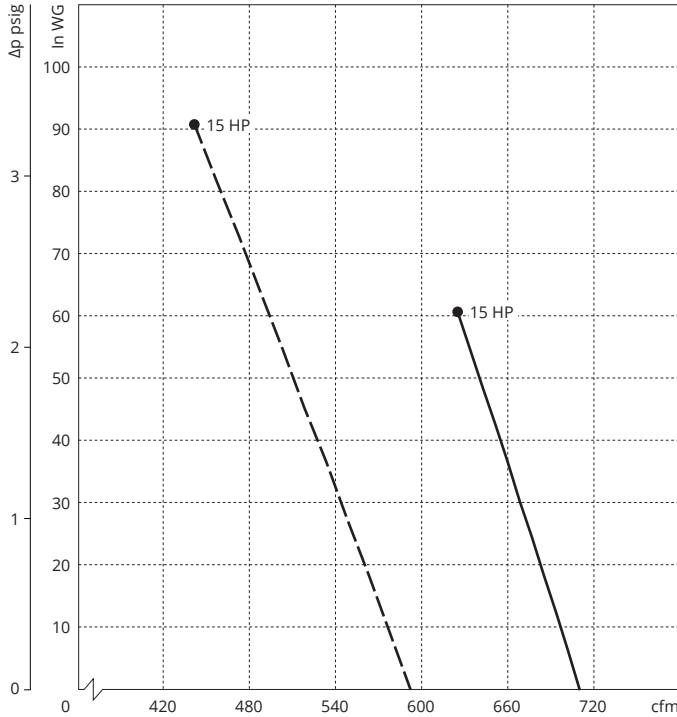

ABSORBED POWER

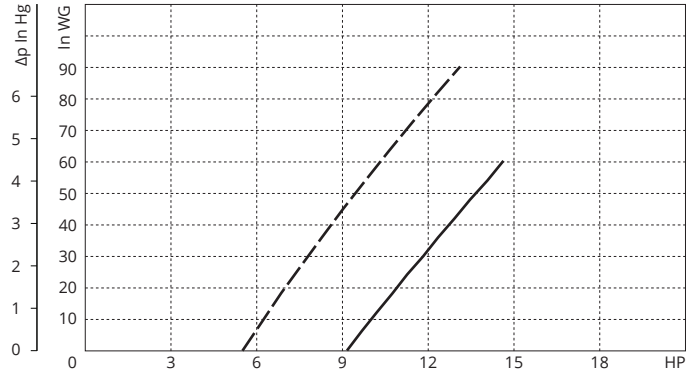
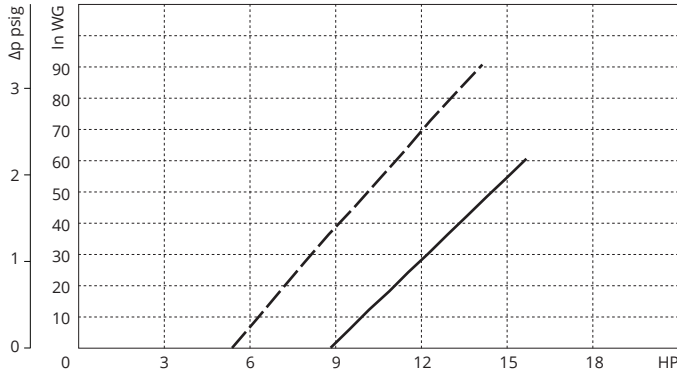

TEMPERATURE INCREASE

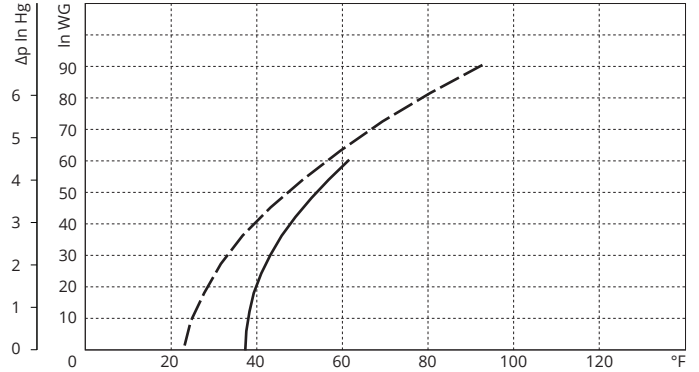
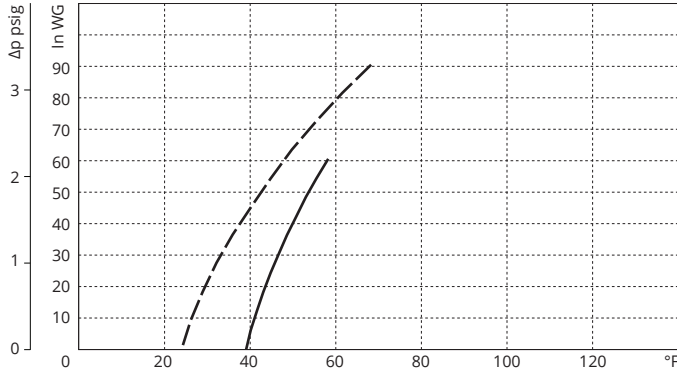

Curves refer to air at 68°F temperature and 29.92 In Hg atmospheric pressure (abs) measured at inlet port. Values for flow, power consumption and temperature rise: +/-10% tolerance. Data subject to change without notice.

**KEY**    --- 50 Hz  
          — 60 Hz



**Evolution Series  
Technical Characteristics**

- Premium efficient motor
- High efficiency impeller

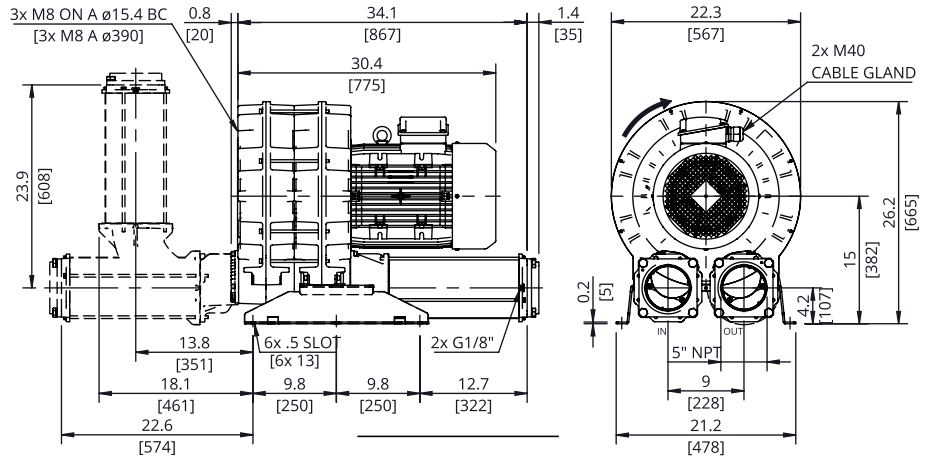

**Technical Specifications**

	HP	Hz	Open Flow (cfm)	Max Pressure in. H <sub>2</sub> O	Max Vacuum in. H <sub>2</sub> O	Efficiency	Voltage	FLA	Starting Current Ratio <sup>1</sup>	dB(A) <sup>2</sup>	Weight (lb)
SCL e11-TS-25-3	25	60	1304	50	50	91.7%	208-230/460	62 / 31	12.5	86	463.0
		50	1092	90	100	92.4%	200/400	69 / 34.5		82	
SCL e11-TS-25-3-575	25	60	1304	50	50	91.7%	575	24.8	12.5	86	463.0
SCL e11-TS-30-3	30	60	1304	70	70	91.7%	208-230/460	71.6 / 35.8	10.6	86	489.4
		50	1092	110	110	92.7%	200/400	77.8 / 38.9		82	
SCL e11-TS-30-3-575	30	60	1304	70	70	91.7%	575	28.6	10.6	86	489.4

Motors include normally closed thermal protector, 1.15 S.F. (60 Hz), tropicalized windings, Class F (B) insulation, and are suitable for use with a VFD (Contact FPZ for pneumatic and speed limits when used with a VFD).

<sup>1</sup>Starting current ratio x fla = starting current

<sup>2</sup>Noise level measured at a distance of 1 m with inlet and outlet ports piped in accordance to ISO 3744

Data is subject to change without notice.

**Recommended Accessories**

Description	Pressure Safety Valve	Vacuum Safety Valve	Pressure Filter	Vacuum Filter	Check Valve
Part number	(2) VRL9 (25 HP) <sup>3</sup>	(2) VRL9 (25 HP) <sup>3</sup>	FL10	CTD-375P-500C	CV5-502M-1330
	(2) VRL9 (30 HP) <sup>3</sup>	(2) VRL9 (30 HP) <sup>3</sup>			

<sup>3</sup>Valve selections are based on 60 Hz and standard air. Valves are supplied uncalibrated. Safety valves are easy to calibrate, but can be ordered with factory calibration.



**PRESSURE**

**VACUUM**

**CAPACITY**

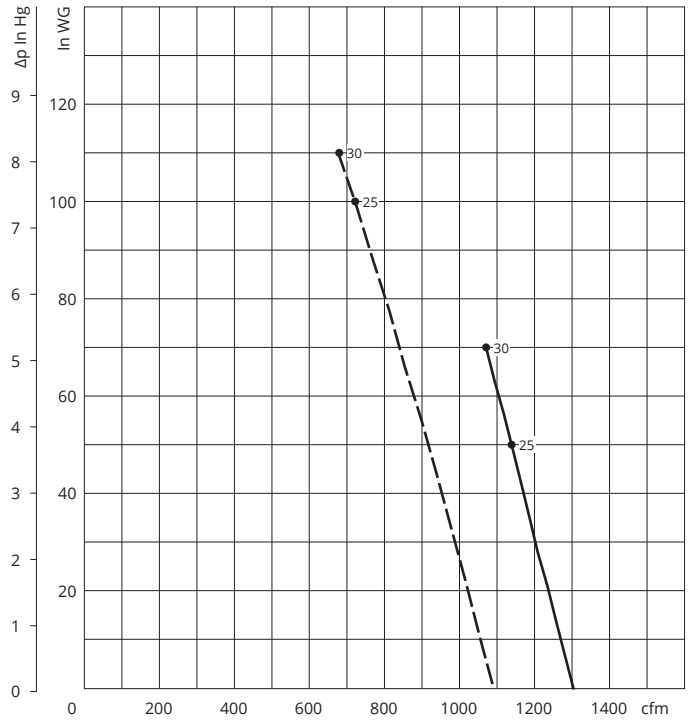
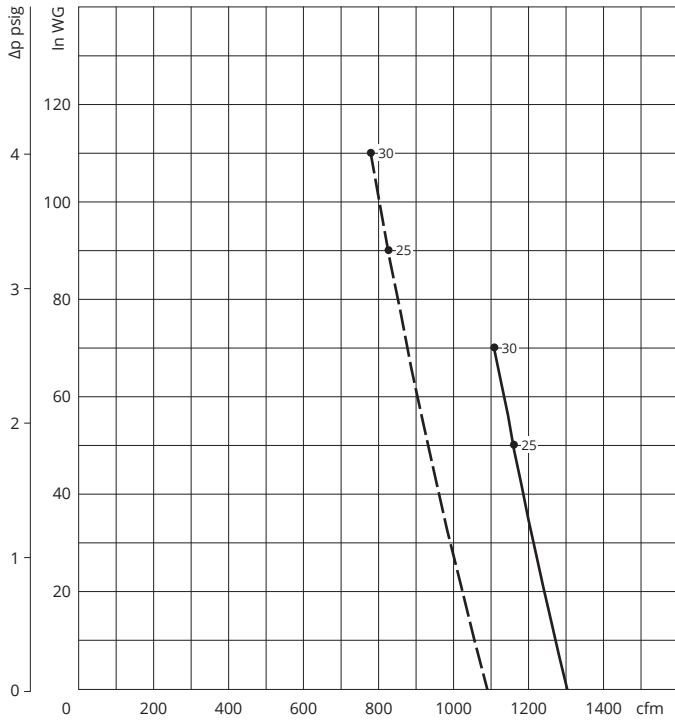

**ABSORBED POWER**

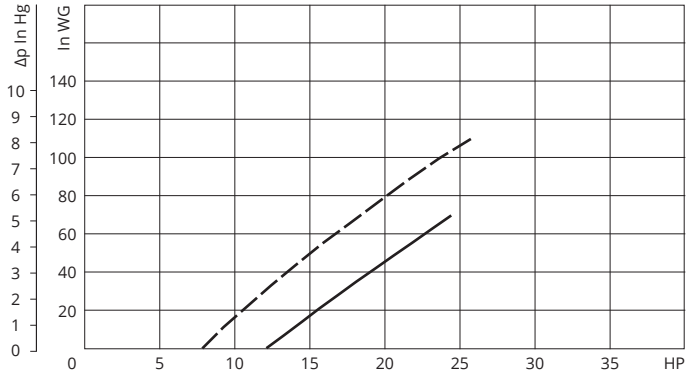
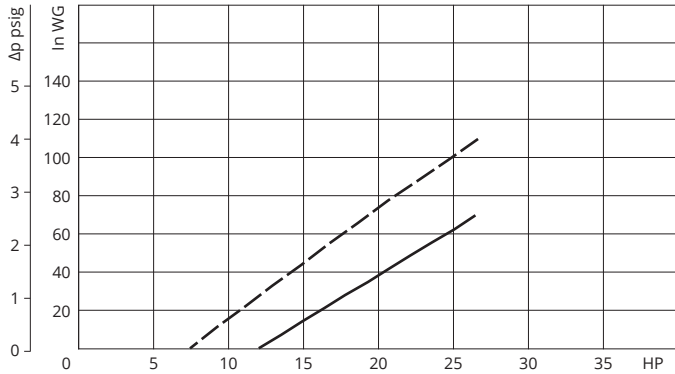

**TEMPERATURE INCREASE**

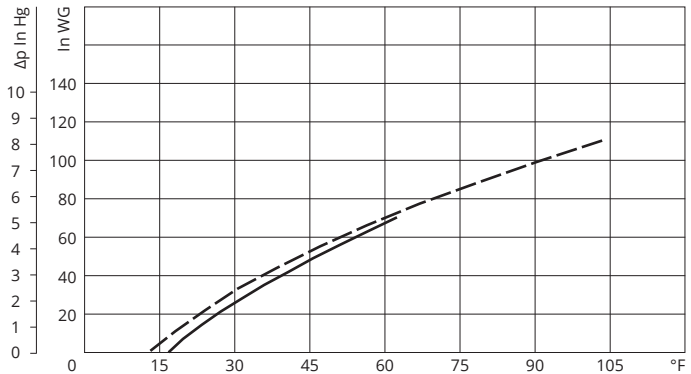
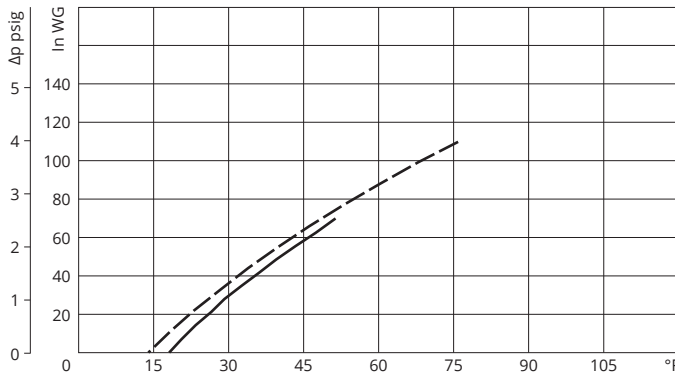

Curves refer to air at 68°F temperature and 29.92 In Hg atmospheric pressure (abs) measured at inlet port.  
Values for flow, power consumption and temperature rise: +/-10% tolerance.  
Data subject to change without notice.

**KEY**    - - - 50 Hz  
          — — — 60 Hz



**Evolution Series  
Technical Characteristics**

- Premium efficient motor
- High efficiency impeller
- Mountable in any position
- Maintenance free operation
- TEFC (IP55)

**Optional Features**

- Anodized aluminum components for corrosion resistance
- Increased sealing

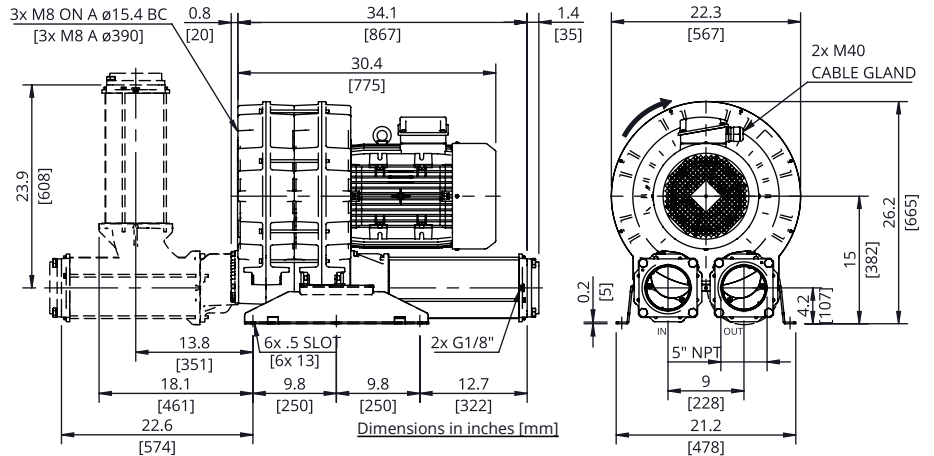

**Technical Specifications**

Model No.	HP	Hz	Open Flow (cfm)	Max Pressure in. H <sub>2</sub> O	Max Vacuum in. H <sub>2</sub> O	Efficiency	Voltage	FLA	Starting Current Ratio <sup>1</sup>	dB(A) <sup>2</sup>	Weight (lb)
<b>SCL e12-TS-30-3</b>	30	60	1492	70	70	91.7%	208-230/460	71.6/35.8	12.5	88	493.8
		50	1238	100	100	92.7%	200/400	77.8/38.9	12.5	84	493.8
<b>SCL e12-TS-30-3-575</b>	30	60	1492	70	70	91.7%	575	28.6	10.6	88	493.8

Motors include normally closed thermal protector, 1.15 S.F. (60 Hz), tropicalized windings, Class F (B) insulation, and are suitable for use with a VFD (Contact FPZ for pneumatic and speed limits when used with a VFD).

<sup>1</sup>Starting current ratio x fla = starting current

<sup>2</sup>Noise level measured at a distance of 1 m with inlet and outlet ports piped in accordance to ISO 3744

Data is subject to change without notice.

**Recommended Accessories**

Description	Pressure Safety Valve	Vacuum Safety Valve	Pressure Filter	Vacuum Filter	Check Valve
Part number	(2) VRL9 (30 HP) <sup>3</sup>	(2) VRL9 (30 HP) <sup>3</sup>	FL10	CTD-375P-500C	CV5-502M-1330

<sup>3</sup>Valve selections are based on 60 Hz and standard air. Valves are supplied uncalibrated. Safety valves are easy to calibrate, but can be ordered with factory calibration.



### PRESSURE

### VACUUM

CAPACITY

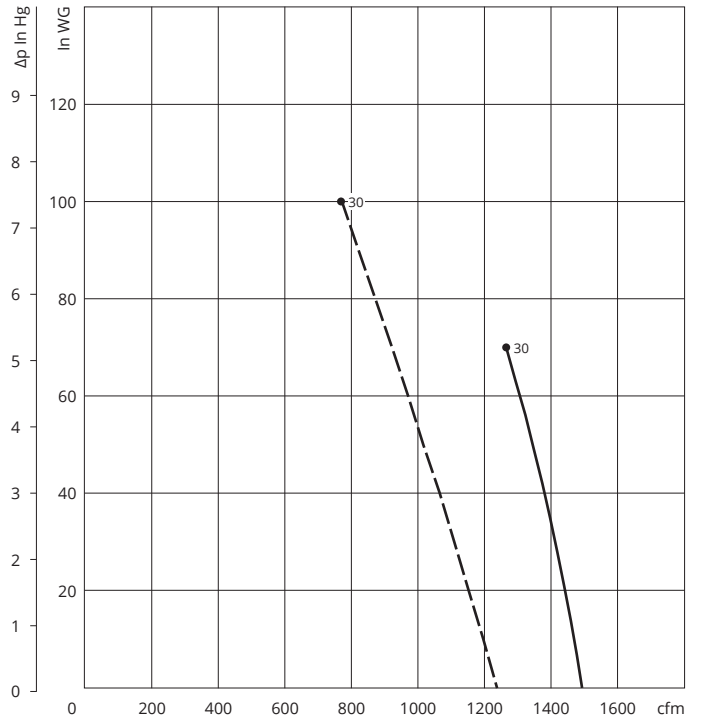
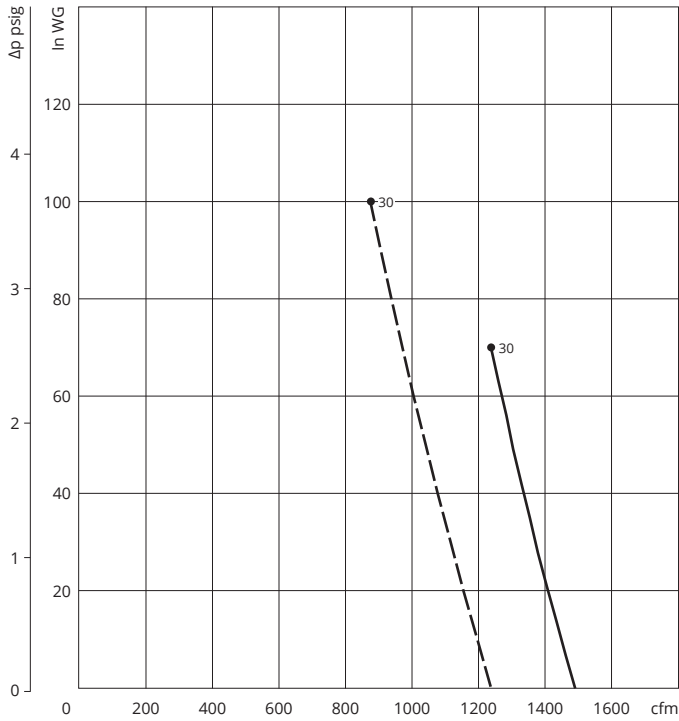

ABSORBED POWER

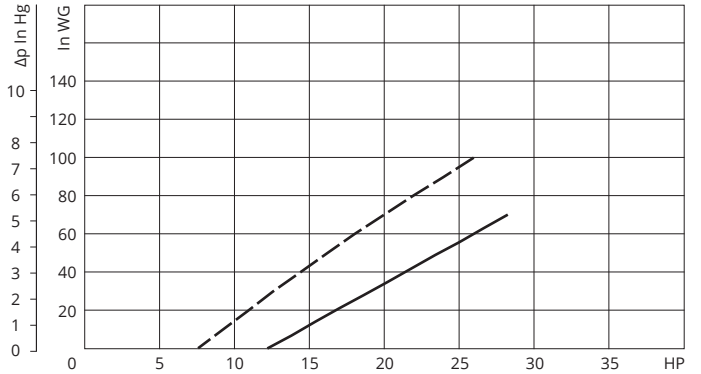
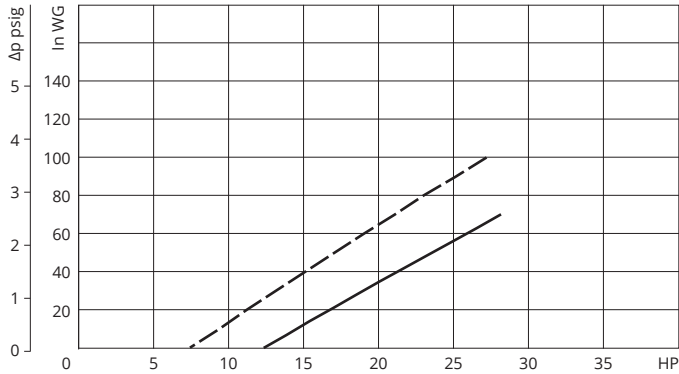

TEMPERATURE INCREASE

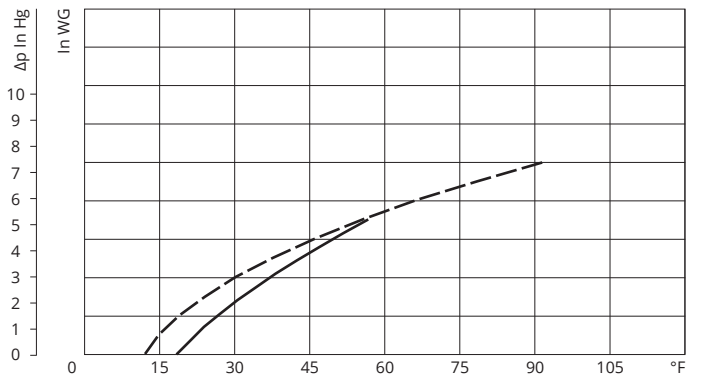
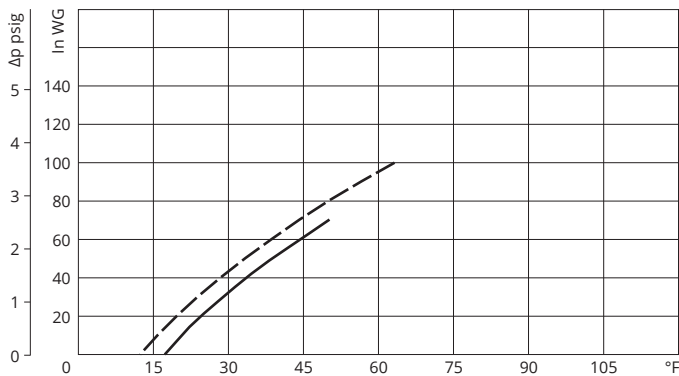

Curves refer to air at 68°F temperature and 29.92 In Hg atmospheric pressure (abs) measured at inlet port.  
Values for flow, power consumption and temperature rise: +/-10% tolerance.  
Data subject to change without notice.

**KEY**    - - - - 50 Hz  
          — — — — 60 Hz



**Evolution Series  
Technical Characteristics**

- Premium efficient motor
- High efficiency impeller
- Mountable in any position
- Maintenance free operation
- TEFC (IP55)

**Optional Features**

- Anodized aluminum components for corrosion resistance
- Increased sealing

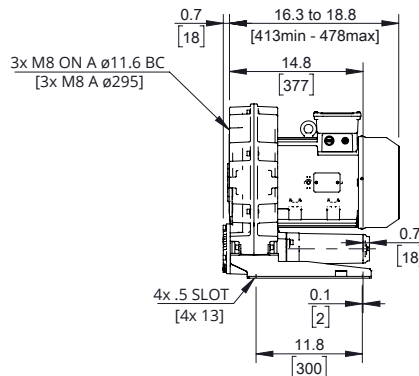

Dimensions in inches [mm]

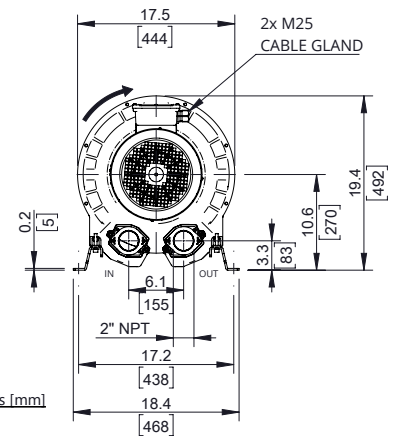

**Technical Specifications**

Model No.	HP	Hz	Open Flow (cfm)	Max Pressure in. H <sub>2</sub> O	Max Vacuum in. H <sub>2</sub> O	Efficiency	Voltage	FLA	Starting Current Ratio <sup>1</sup>	dB(A) <sup>2</sup>	Weight (lb)
SCL e07-MD-5.5-3	5.5	60	147	140	170	88.5%	208-230/460	14.6-15.1/7.55	11.1	77	130.1
		50	123	200	180	88.1%	200/400	17.7/8.86		72	
SCL e07-MD-5.5-3-575	5.5	60	147	140	170	88.5%	575	5.31	10.9	77	130.1
SCL e07-MD-7.5-3	7.5	60	147	220	180	89.5%	208-230/460	19.8-19.5/9.75	13.7	78	154.3
		50	123	260	—	89.2%	200/400	22.2/11.1		72	
SCL e07-MD-7.5-3-575	7.5	60	147	220	180	89.5%	575	7.21	13.5	77	154.3
SCL e07-MD-10-3	10	60	147	260	—	90.2%	208-230/460	26.1-25 / 12.5	13	77	171.2
		50	123	—	—	90.1%	200/400	28.6/14.3		72	
SCL e07-MD-10-3-575	10	60	147	260	—	90.2%	575	10	12.9	77	171.3

Motors include normally closed thermal protector, 1.15 S.F. (60 Hz), tropicalized windings, Class F (B) insulation, and are suitable for use with a VFD (Contact FPZ for pneumatic and speed limits when used with a VFD).

<sup>1</sup>Starting current ratio x fla = starting current

<sup>2</sup>Noise level measured at a distance of 1 m with inlet and outlet ports piped in accordance to ISO 3744

Data is subject to change without notice.

**Recommended Accessories**

Description	Pressure Safety Valve	Vacuum Safety Valve	Pressure Filter	Vacuum Filter	Check Valve
Part Number	VRL6 (5.5 hp - 7.5hp) <sup>3</sup> VRL6-HP (10 hp) <sup>3</sup>	VRL6	FS-231P-200	CSL-851-200HC	CV20

<sup>3</sup>Valve selections are based on 60 Hz and standard air. Valves are supplied uncalibrated. Safety valves are easy to calibrate, but can be ordered with factory calibration.



### PRESSURE

### VACUUM

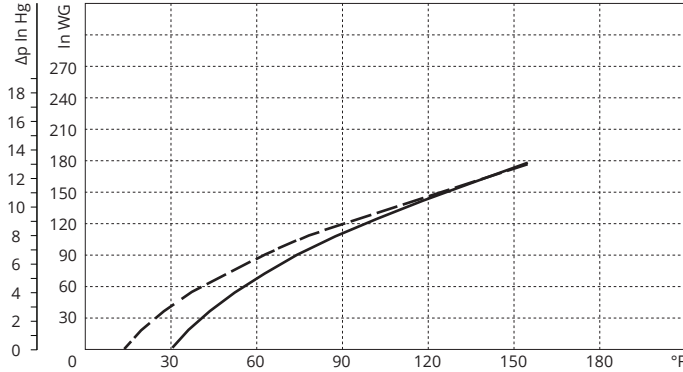
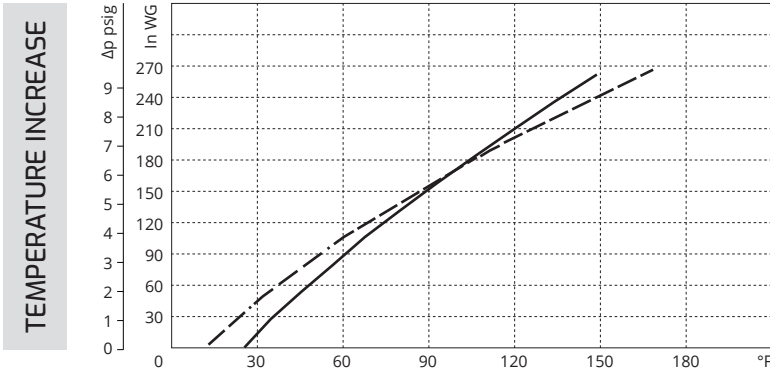
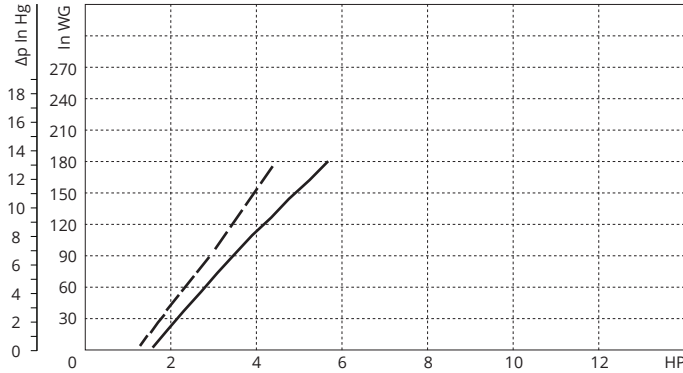
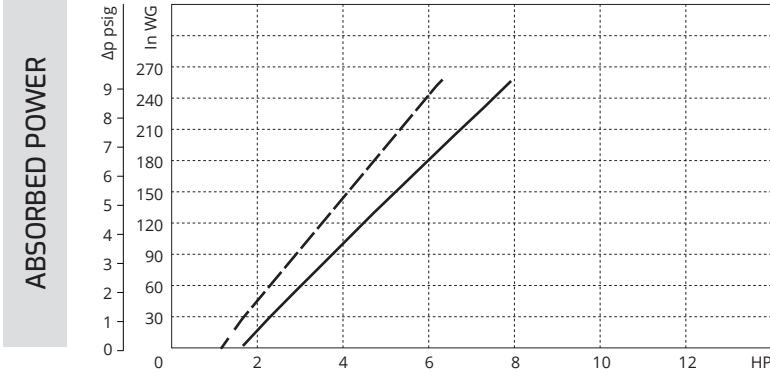
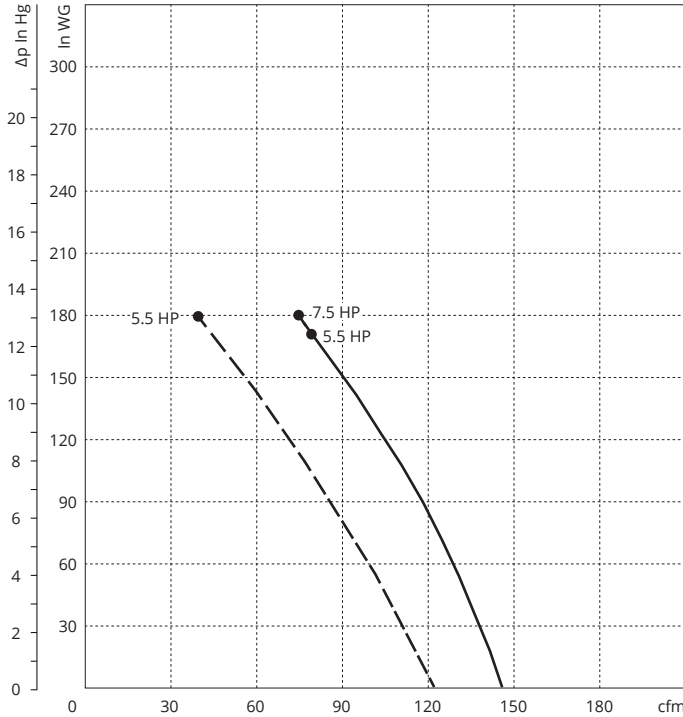
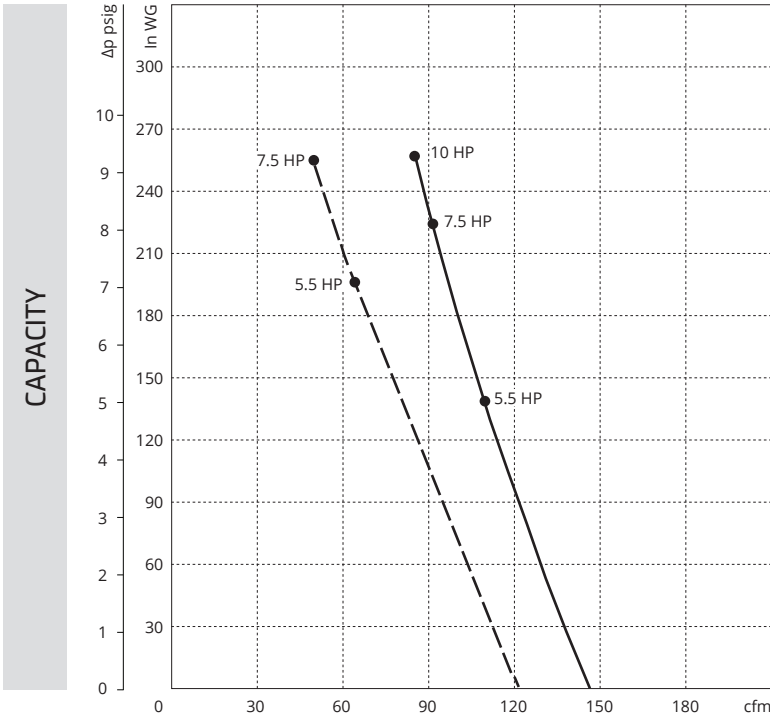

Curves refer to air at 68°F temperature and 29.92 In Hg atmospheric pressure (abs) measured at inlet port.  
 Values for flow, power consumption and temperature rise: +/-10% tolerance.  
 Data subject to change without notice.

**KEY**    --- 50 Hz  
           — 60 Hz





**Evolution Series  
Technical Characteristics**

- Premium efficient motor
- High efficiency impeller
- Mountable in any position
- Maintenance free operation
- TEFC (IP55)

**Optional Features**

- Anodized aluminum components for corrosion resistance
- Increased sealing

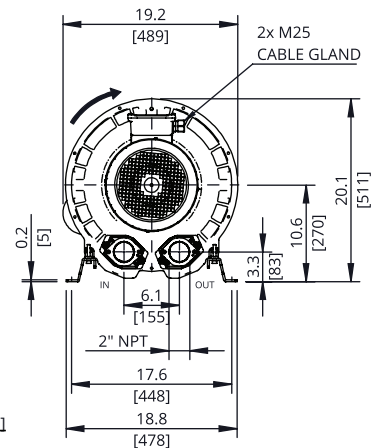
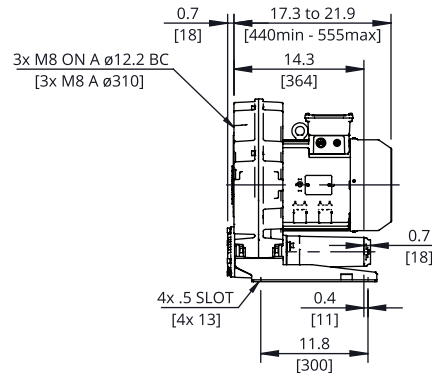

Dimensions in inches [mm]

**Technical Specifications**

Model No.	HP	Hz	Open Flow (cfm)	Max Pressure in. H <sub>2</sub> O	Max Vacuum in. H <sub>2</sub> O	Efficiency	Voltage	FLA	Starting Current Ratio <sup>1</sup>	dB(A) <sup>2</sup>	Weight (lb)
SCL e08-MD-5.5-3	5.5	60	177	60	90	88.5%	208-230/460	14.6-15.1/7.55	11.1	78	145.5
		50	150	140	150	88.1%	200/400	17.7/8.86		73	
SCL e08-MD-5.5-3-575	5.5	60	177	60	90	88.5%	575	5.31	10.9	78	145.5
SCL e08-MD-7.5-3	7.5	60	177	140	160	89.5%	208-230/460	19.8-19.5/9.75	13.7	78	182.5
		50	150	200	180	89.2%	200/400	22.2/11.1		73	
SCL e08-MD-7.5-3-575	7.5	60	177	140	160	89.5%	575	7.21	13.5	78	182.5
SCL e08-MD-10-3	10	60	177	200	180	90.2%	208-230/460	26.1-25 / 12.5	13	78	196.2
		50	150	260	—	90.1%	200/400	28.6/14.3		73	
SCL e08-MD-10-3-575	10	60	177	200	180	90.2%	575	10	12.9	78	196.2
SCL e08-MD-15-3	15	60	177	260	—	91.0%	208-230/460	38.2-37.3/18.7	12.5	78	211.6
		50	150	—	—	91.0%	200/400	43.4 / 21.7		73	
SCL e08-MD-15-3-575	15	60	177	260	—	91.0%	575	13.9	11	78	211.6

Motors include normally closed thermal protector, 1.15 S.F. (60 Hz), tropicalized windings, Class F (B) insulation, and are suitable for use with a VFD (Contact FPZ for pneumatic and speed limits when used with a VFD).

<sup>1</sup>Starting current ratio x fla = starting current

<sup>2</sup>Noise level measured at a distance of 1 m with inlet and outlet ports piped in accordance to ISO 3744

Data is subject to change without notice.

**Recommended Accessories**

Description	Pressure Safety Valve	Vacuum Safety Valve	Pressure Filter	Vacuum Filter	Check Valve
Part Number	VRL6 (5.5 hp - 10 hp) <sup>3</sup> VRL6-HP (15 hp) <sup>3</sup>	VRL6	FS-231P-200	CSL-851-200HC	CV20

<sup>3</sup>Valve selections are based on 60 Hz and standard air. Valves are supplied uncalibrated. Safety valves are easy to calibrate, but can be ordered with factory calibration.





### PRESSURE

### VACUUM

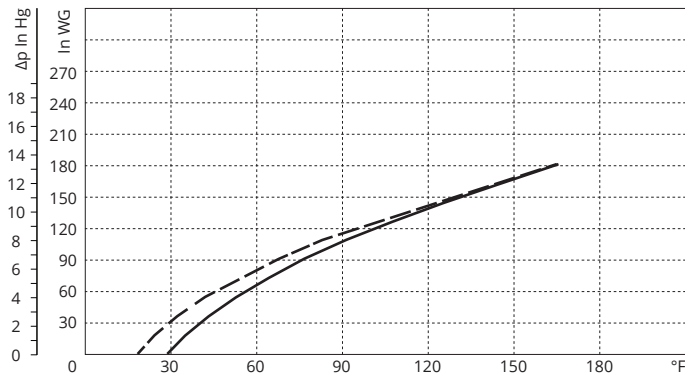
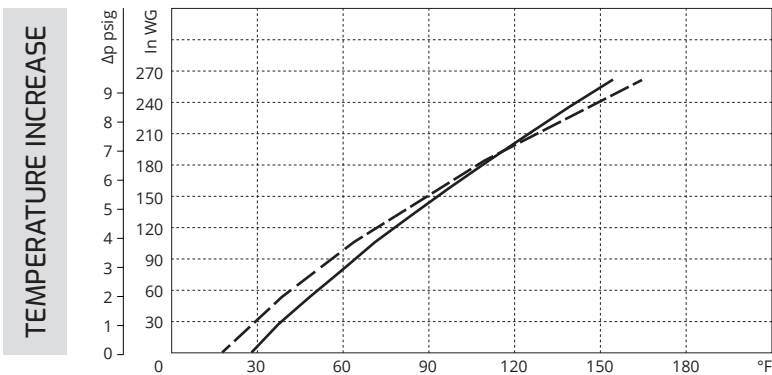
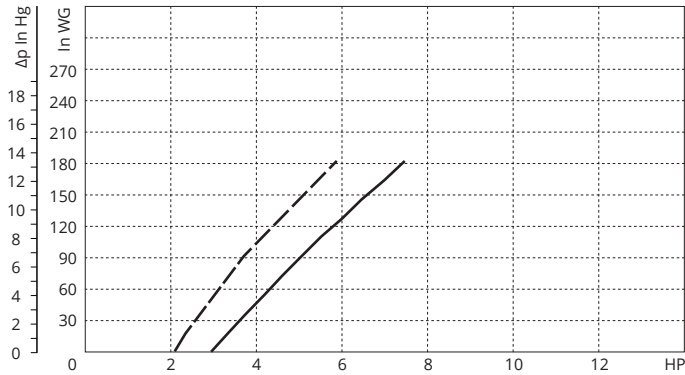
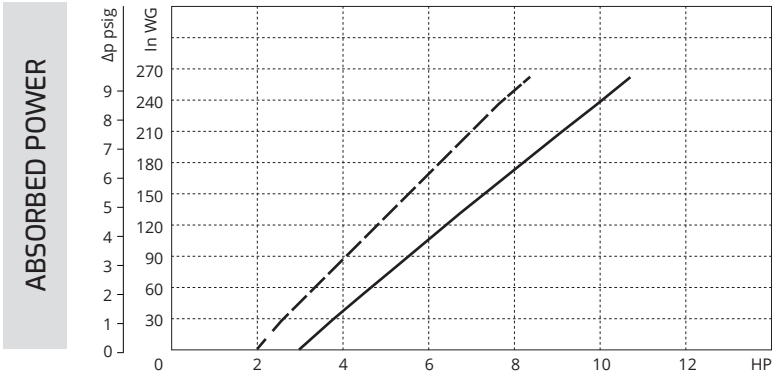
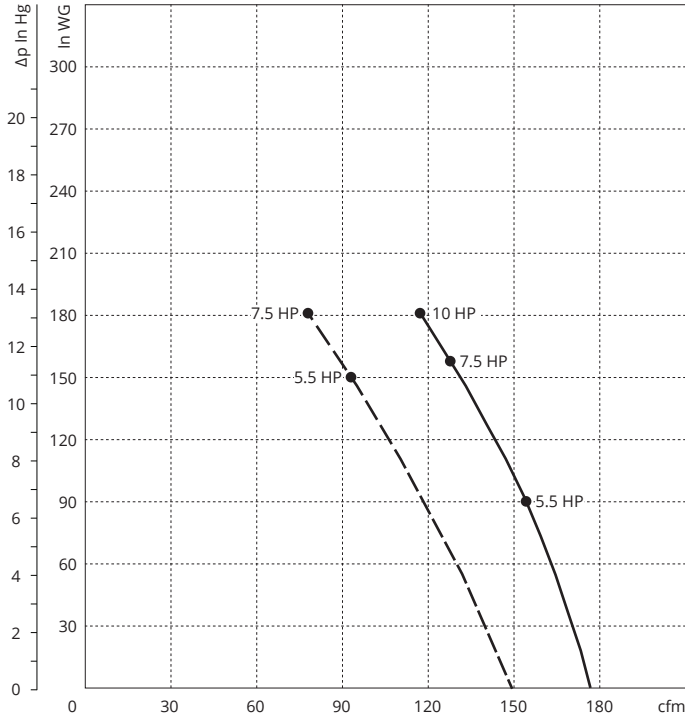
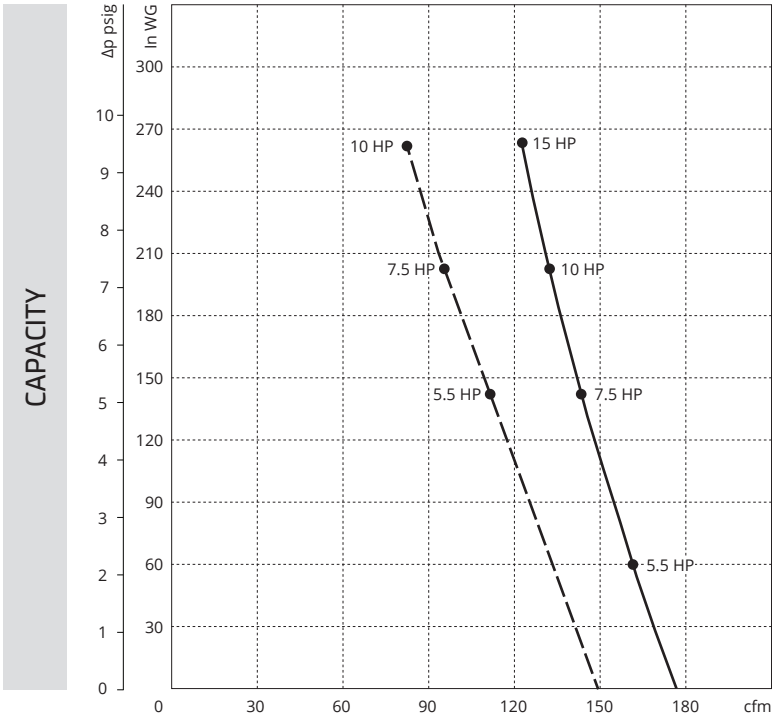

Curves refer to air at 68°F temperature and 29.92 In Hg atmospheric pressure (abs) measured at inlet port.  
 Values for flow, power consumption and temperature rise: +/-10% tolerance.  
 Data subject to change without notice.

**KEY**    --- 50 Hz  
           — 60 Hz



**e11-MD**

**Evolution Series  
Technical Characteristics**

- Premium efficient motor
- High efficiency impeller
- Mountable in any position
- Maintenance free operation
- TEFC (IP55)

**Optional Features**

- Anodized aluminum components for corrosion resistance
- Increased sealing

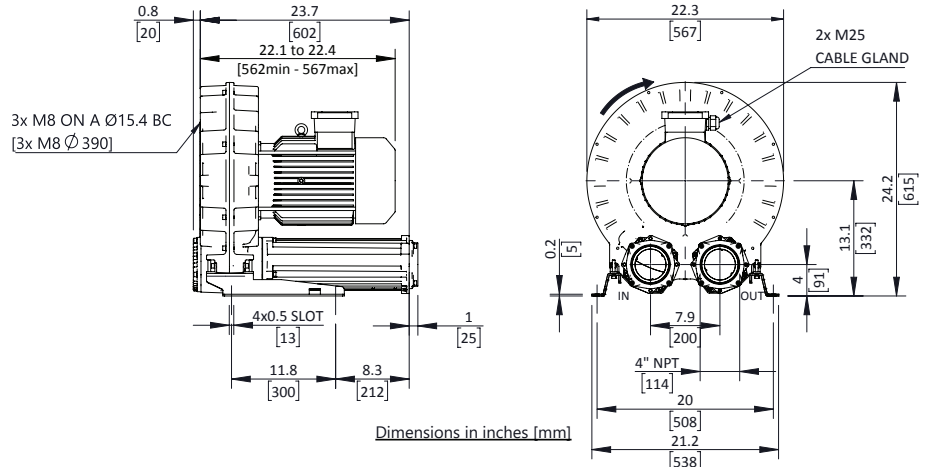

**Technical Specifications**

Model No.	HP	Hz	Open Flow (cfm)	Max Pressure in. H <sub>2</sub> O	Max Vacuum in. H <sub>2</sub> O	Efficiency	Voltage	FLA	Starting Current Ratio <sup>1</sup>	dB(A) <sup>2</sup>	Weight (lb)
<b>SCL e11-MD-15-3</b>	15	60	319	180	180	91.0%	208-230/460	38.2-37.3/18.7	12.5	80	245.8
		50	270	260	170	91.0%	200/400	43.4 / 21.7		77	245.8
<b>SCL e11-MD-15-3-575</b>	15	60	319	180	180	91.0%	575	13.9	11	80	245.8
<b>SCL e11-MD-20-3</b>	20	60	319	280	-	91.7%	208-230/460	47.0 / 23.5	9.7	80	271.2
		50	270	-	-	91.9%	200/400	52.4 / 26.2		77	271.2
<b>SCL e11-MD-20-3-575</b>	20	60	319	280	-	91.0%	575	18.8	9.8	80	271.2

Motors include normally closed thermal protector, 1.15 S.F. (60 Hz), tropicalized windings, Class F (B) insulation, and are suitable for use with a VFD (Contact FPZ for pneumatic and speed limits when used with a VFD).

<sup>1</sup>Starting current ratio x fla = starting current

<sup>2</sup>Noise level measured at a distance of 1 m with inlet and outlet ports piped in accordance to ISO 3744

Data is subject to change without notice.

**Recommended Accessories**

Description	Pressure Safety Valve	Vacuum Safety Valve	Pressure Filter	Vacuum Filter	Check Valve
Part number	VRL6 HP (20HP) <sup>3</sup> VRL6 (15HP) <sup>3</sup>	VRL6 <sup>3</sup>	FS-235P-400	CT-235P-400C	CV40

<sup>3</sup>Valve selections are based on 60 Hz and standard air. Valves are supplied uncalibrated. Safety valves are easy to calibrate, but can be ordered with factory calibration.



### PRESSURE

### VACUUM

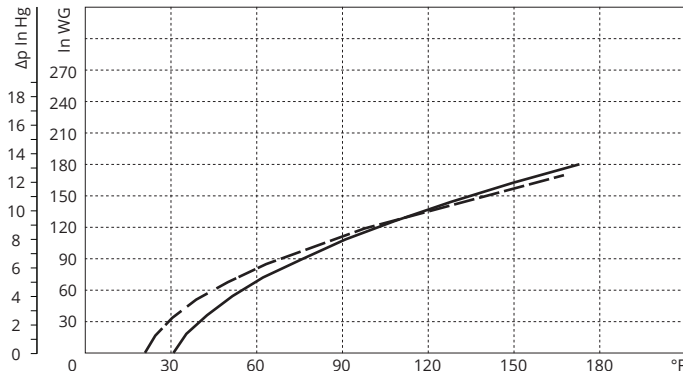
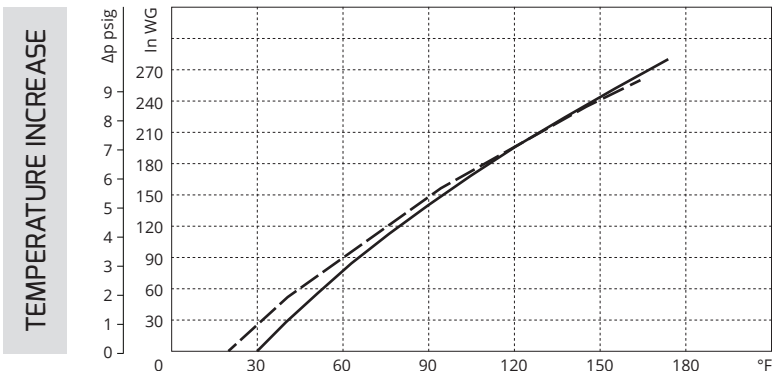
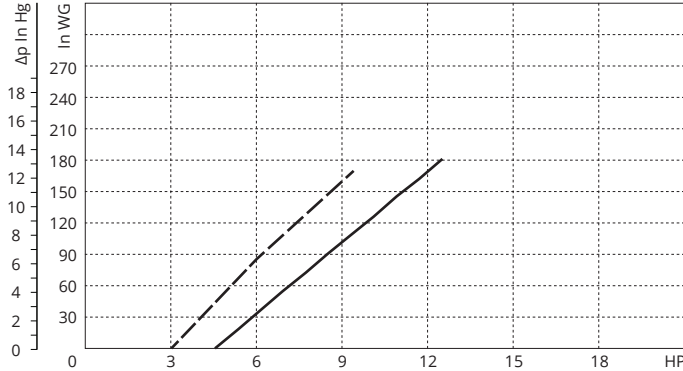
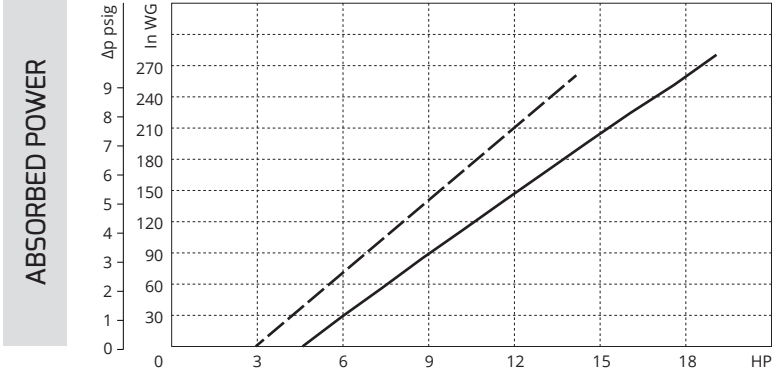
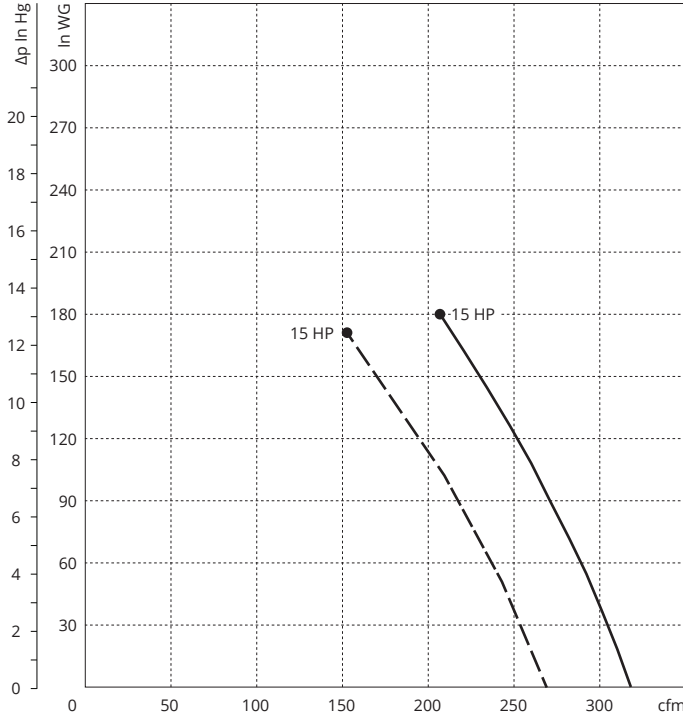
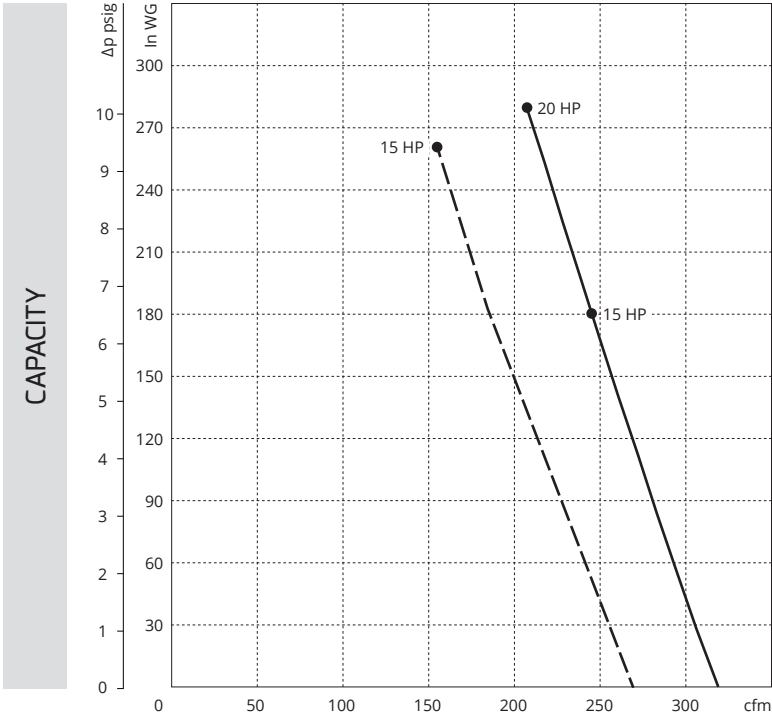

Curves refer to air at 68°F temperature and 29.92 In Hg atmospheric pressure (abs) measured at inlet port.  
 Values for flow, power consumption and temperature rise: +/-10% tolerance.  
 Data subject to change without notice.

**KEY**    --- 50 Hz  
           — 60 Hz



**e12-MD**

**Evolution Series  
Technical Characteristics**

- Premium efficient motor
- High efficiency impeller
- Mountable in any position
- Maintenance free operation
- TEFC (IP55)

**Optional Features**

- Anodized aluminum components for corrosion resistance
- Increased sealing

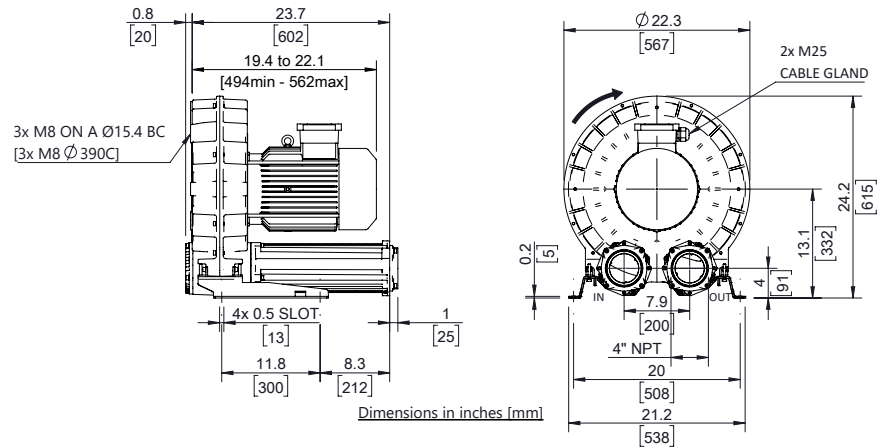

**Technical Specifications**

Model No.	HP	Hz	Open Flow (cfm)	Max Pressure in. H <sub>2</sub> O	Max Vacuum in. H <sub>2</sub> O	Efficiency	Voltage	FLA	Starting Current Ratio <sup>1</sup>	dB(A) <sup>2</sup>	Weight (lb)
<b>SCL e12-MD-15-3</b>	15	60	367	140	170	91.0%	208-230/460	38.2-37.3/18.7	12.5	80	248.1
		50	307	220	170	91.0%	200/400	43.4 / 21.7		77	248.1
<b>SCL e12-MD-15-3-575</b>	15	60	367	140	180	91.0%	575	13.9	11	80	248.1
<b>SCL e12-MD-20-3</b>	20	60	367	240	-	91.7%	208-230/460	47.0 / 23.5	9.7	80	273.5
		50	307	260	-	91.9%	200/400	52.4 / 26.2		77	273.5
<b>SCL e12-MD-20-3-575</b>	20	60	367	240	-	91.0%	575	18.8	9.8	80	273.5

Motors include normally closed thermal protector, 1.15 S.F. (60 Hz), tropicalized windings, Class F (B) insulation, and are suitable for use with a VFD (Contact FPZ for pneumatic and speed limits when used with a VFD).

<sup>1</sup>Starting current ratio x fla = starting current

<sup>2</sup>Noise level measured at a distance of 1 m with inlet and outlet ports piped in accordance to ISO 3744

Data is subject to change without notice.

**Recommended Accessories**

Description	Pressure Safety Valve	Vacuum Safety Valve	Pressure Filter	Vacuum Filter	Check Valve
Part number	VRL6 <sup>3</sup>	VRL6 <sup>3</sup>	FS-235P-400	CT-235P-400C	CV40

<sup>3</sup>Valve selections are based on 60 Hz and standard air. Valves are supplied uncalibrated. Safety valves are easy to calibrate, but can be ordered with factory calibration.



### PRESSURE

### VACUUM

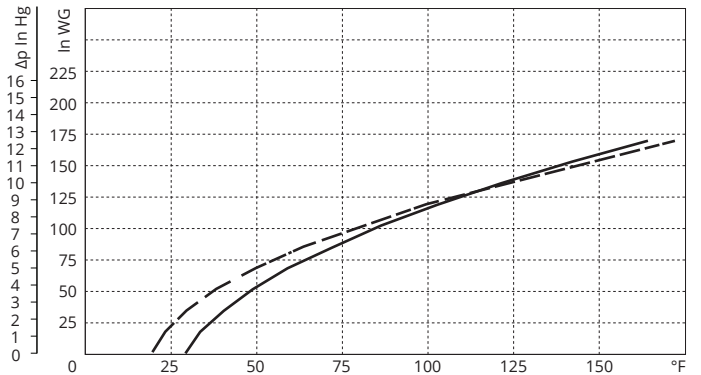
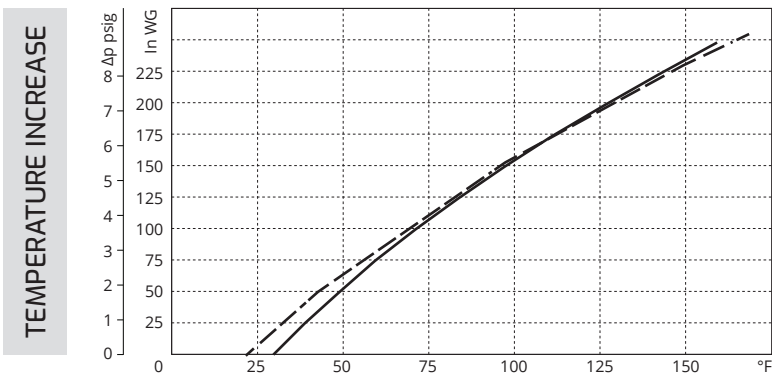
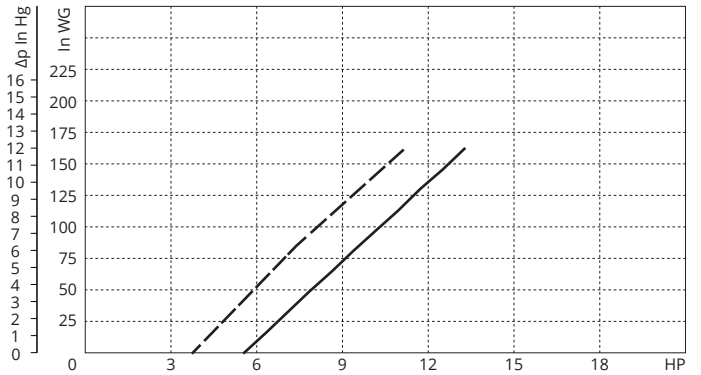
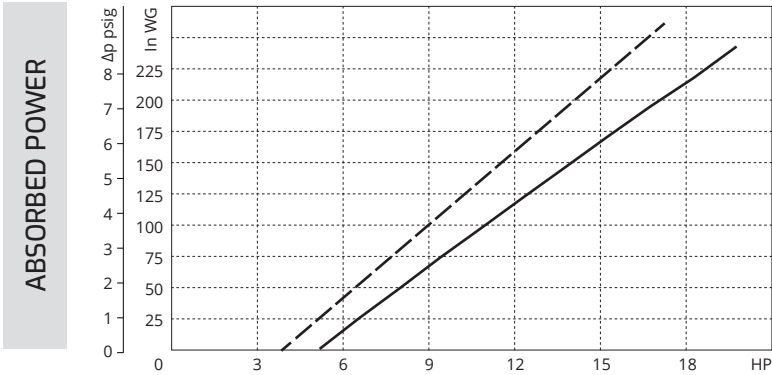
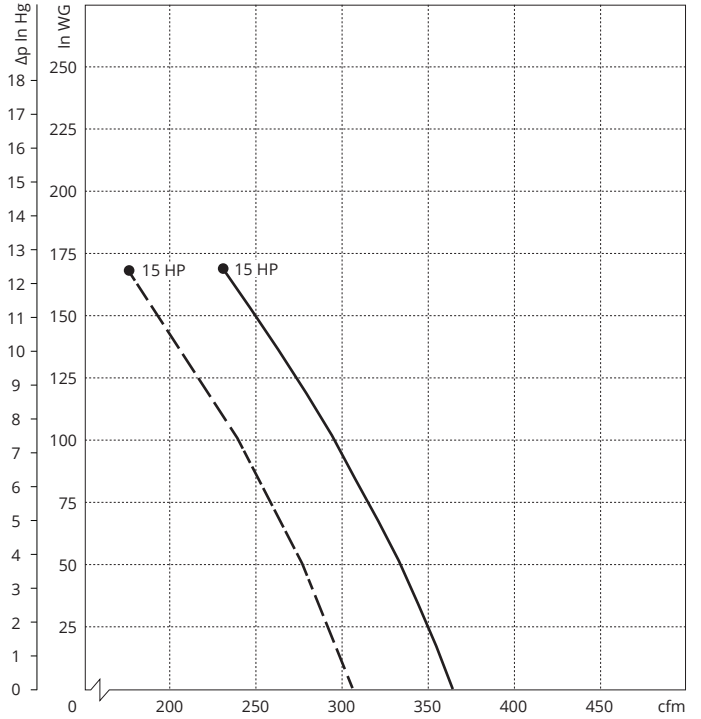
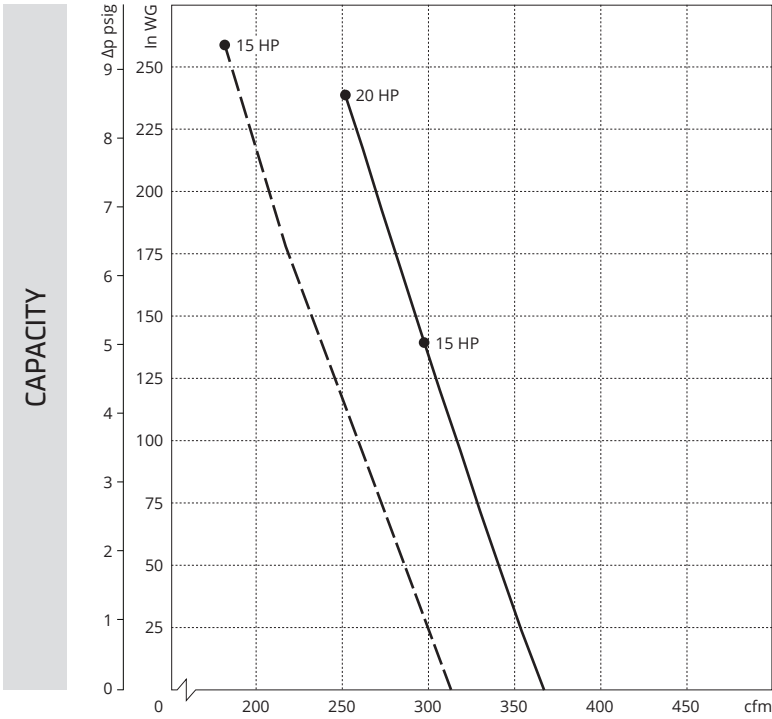

Curves refer to air at 68°F temperature and 29.92 In Hg atmospheric pressure (abs) measured at inlet port.  
 Values for flow, power consumption and temperature rise: +/-10% tolerance.  
 Data subject to change without notice.

**KEY**    --- 50 Hz  
 ——— 60 Hz



e07-TD

**Evolution Series  
Technical Characteristics**

- Premium efficient motor
- High efficiency impeller
- Mountable in any position
- Maintenance free operation
- TEFC (IP55)

**Optional Features**

- Anodized aluminum components for corrosion resistance
- Increased sealing

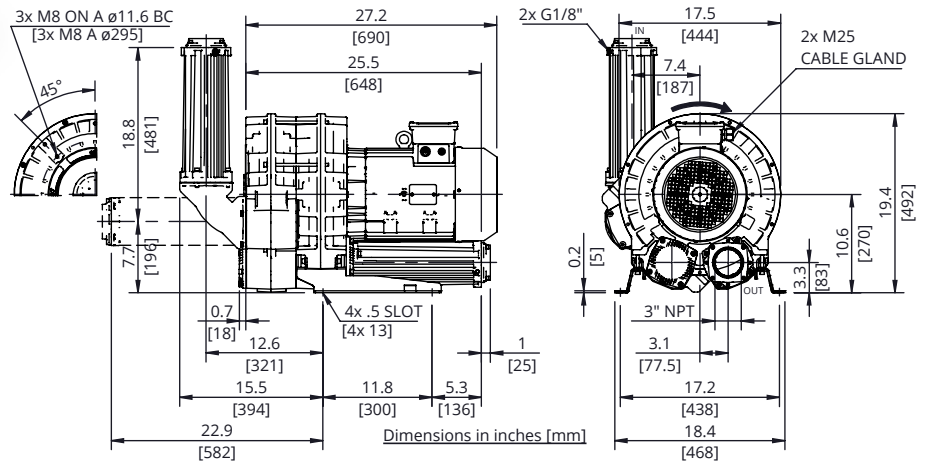

**Technical Specifications**

Model No.	HP	Hz	Open Flow (cfm)	Max Pressure in. H <sub>2</sub> O	Max Vacuum in. H <sub>2</sub> O	Efficiency	Voltage	FLA	Starting Current Ratio <sup>1</sup>	dB(A) <sup>2</sup>	Weight (lb)
SCL e07-TD-15-3	15	60	304	220	170	91.0%	208-230/460	38.2-37.3/18.7	12.5	77.0	262.3
		50	255	220	160	91.2%	200/400	43.4/21.7		74.0	
SCL e07-TD-15-3-575	15	60	304	220	170	91.0%	575	13.9	11	77.0	262.3

Motors include normally closed thermal protector, 1.15 S.F. (60 Hz), tropicalized, Class F (B) insulation, and are suitable for use with VFD (Contact FPZ for pneumatic and speed limits when used with a VFD).

<sup>1</sup>Starting current ratio x fla = starting current

<sup>2</sup>Noise level measured at a distance of 1 m with inlet and outlet ports piped in accordance to ISO 3744

Data is subject to change without notice.

**Recommended Accessories**

Description	Pressure Safety Valve	Vacuum Safety Valve	Pressure Filter	Vacuum Filter	Check Valve
Part Number	VRL6 <sup>3</sup>	VRL6 <sup>3</sup>	FS-235P-300	CT-235P-300C	CV30

<sup>3</sup>Valve selections are based on 60 Hz and standard air. Valves are supplied uncalibrated. Safety valves are easy to calibrate, but can be ordered with factory calibration.





### PRESSURE

### VACUUM

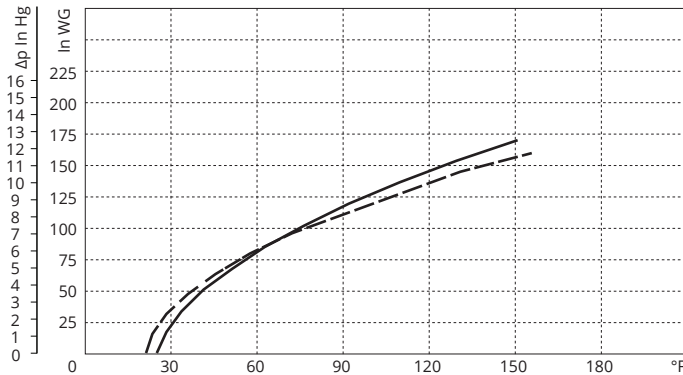
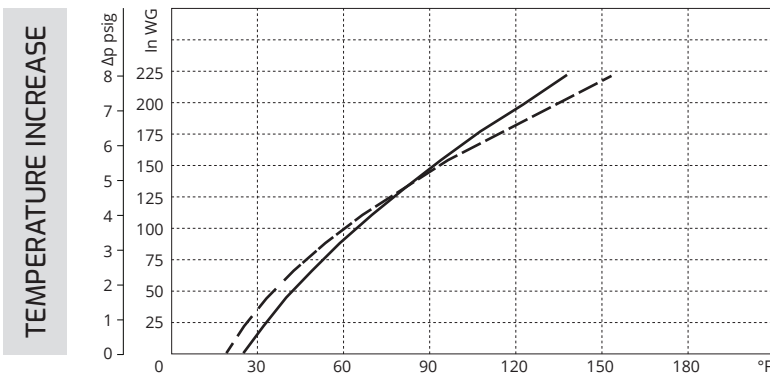
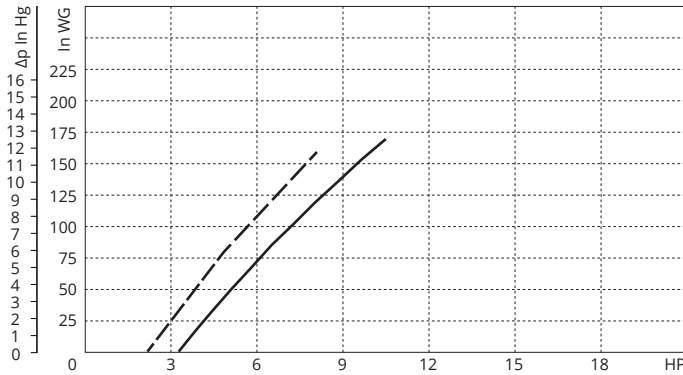
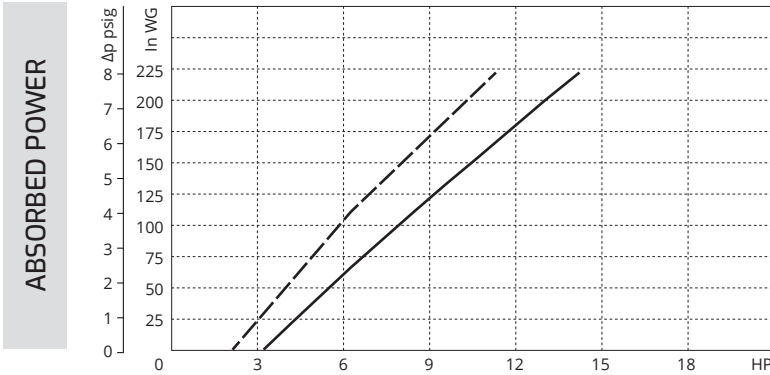
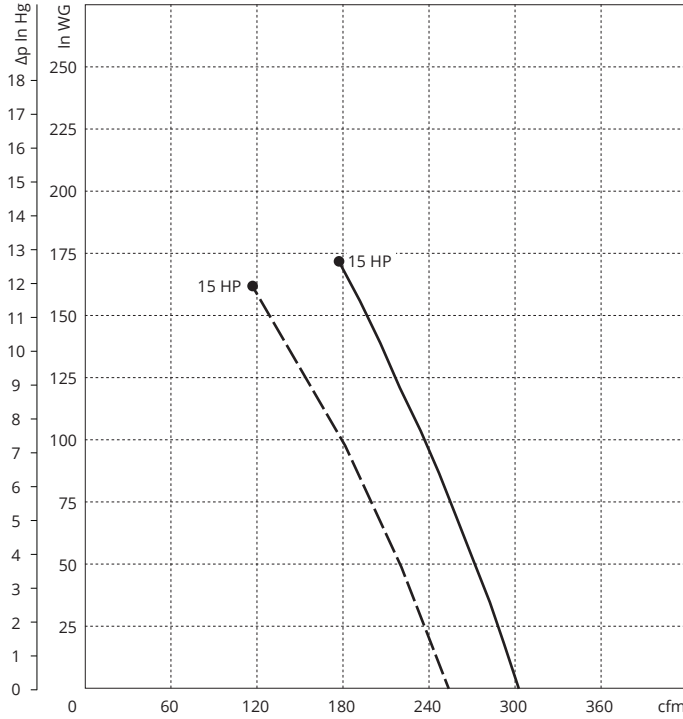
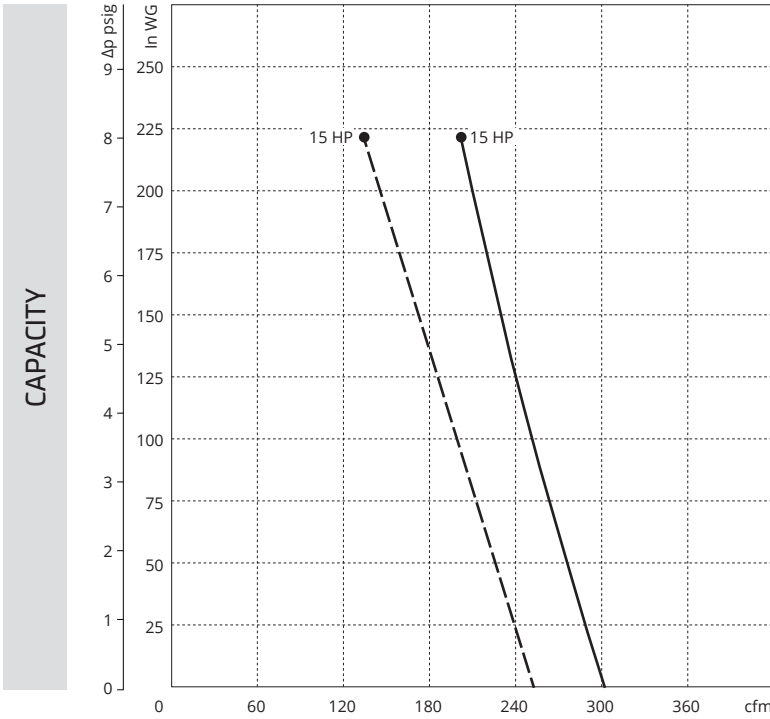

Curves refer to air at 68°F temperature and 29.92 In Hg atmospheric pressure (abs) measured at inlet port.  
 Values for flow, power consumption and temperature rise: +/-10% tolerance.  
 Data subject to change without notice.

**KEY**    --- 50 Hz  
           — 60 Hz



**Evolution Series  
Technical Characteristics**

- Premium efficient motor
- High efficiency impeller
- Mountable in any position
- Maintenance free operation
- TEFC (IP55)

**Optional Features**

- Anodized aluminum components for corrosion resistance
- Increased sealing

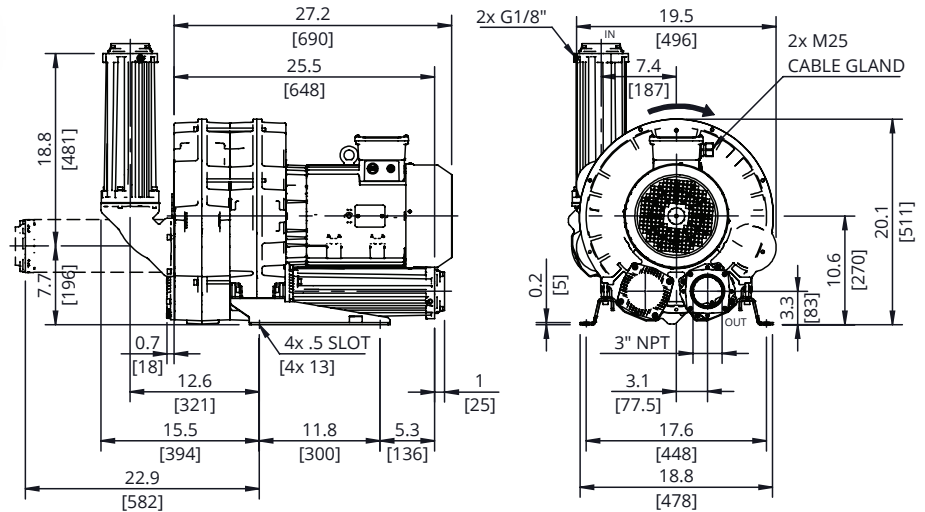

**e08-TD**

**Technical Specifications**

Model No.	HP	Hz	Open Flow (cfm)	Max Pressure in. H <sub>2</sub> O	Max Vacuum in. H <sub>2</sub> O	Efficiency	Voltage	FLA	Starting Current Ratio <sup>1</sup>	dB(A) <sup>2</sup>	Weight (lb)
<b>SCL e08-TD-15-3</b>	15	60	406	160	170	91.0%	208-230/460	38.2-37.3/18.7	12.5	81.5	277.8
		50	340	220	170	91.2%	200/400	43.4/21.7		79.5	
<b>SCL e08-TD-15-3-575</b>	15	60	406	160	170	91.0%	575	13.9	11	81.5	277.8

Motors include normally closed thermal protector, 1.15 S.F. (60 Hz), tropicalized, Class F (B) insulation, and are suitable for use with VFD (Contact FPZ for pneumatic and speed limits when used with a VFD).

<sup>1</sup>Starting current ratio x fla = starting current

<sup>2</sup>Noise level measured at a distance of 1 m with inlet and outlet ports piped in accordance to ISO 3744

Data is subject to change without notice.

**Recommended Accessories**

Description	Pressure Safety Valve	Vacuum Safety Valve	Pressure Filter	Vacuum Filter	Check Valve
Part Number	VRL6 <sup>3</sup>	VRL6 <sup>3</sup>	FS-235P-300	CT-235P-300C	CV30

<sup>3</sup>Valve selections are based on 60 Hz and standard air. Valves are supplied uncalibrated. Safety valves are easy to calibrate, but can be ordered with factory calibration.





### PRESSURE

### VACUUM

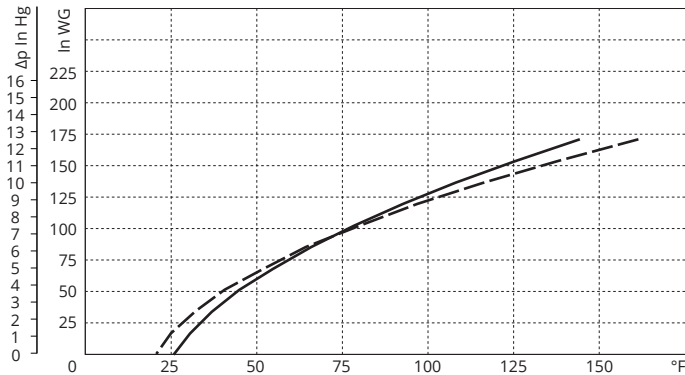
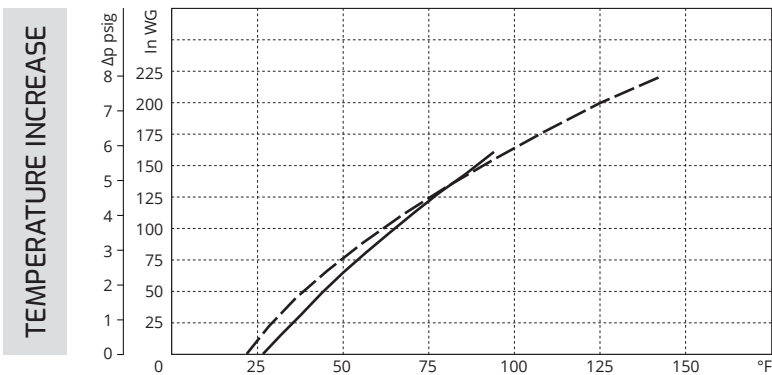
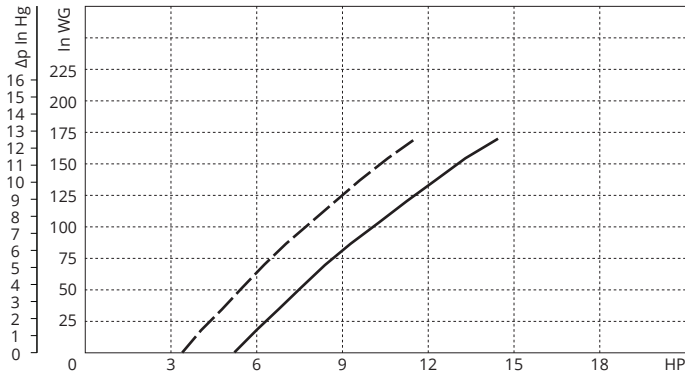
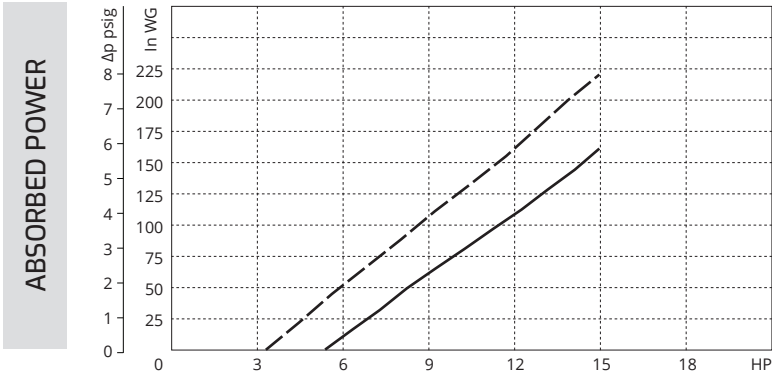
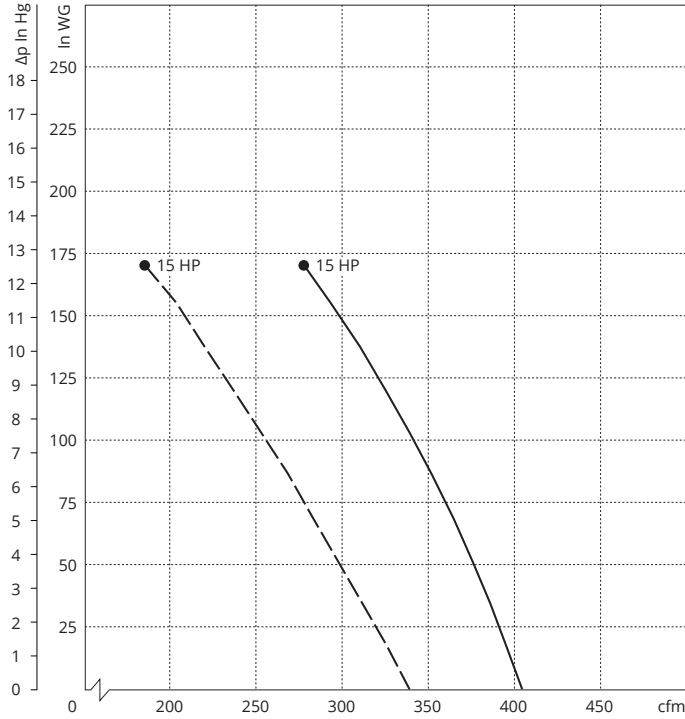
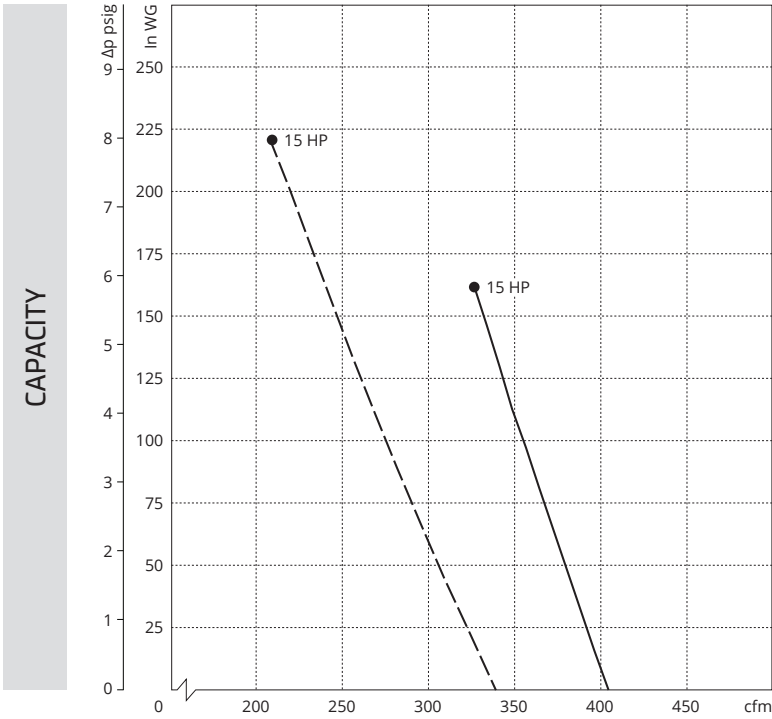

Curves refer to air at 68°F temperature and 29.92 In Hg atmospheric pressure (abs) measured at inlet port.  
 Values for flow, power consumption and temperature rise: +/-10% tolerance.  
 Data subject to change without notice.

**KEY**    --- 50 Hz  
 ——— 60 Hz



**Evolution Series  
Technical Characteristics**

- Premium efficient motor
- High efficiency impeller
- Mountable in any position
- Maintenance free operation
- TEFC (IP55)

**Optional Features**

- Anodized aluminum components for corrosion resistance
- Increased sealing

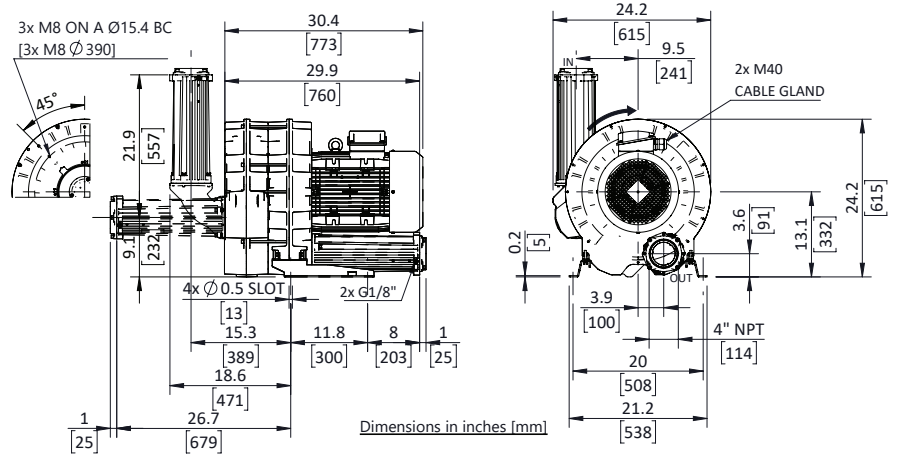

**Technical Specifications**

Model No.	HP	Hz	Open Flow (cfm)	Max Pressure in. H <sub>2</sub> O	Max Vacuum in. H <sub>2</sub> O	Efficiency	Voltage	FLA	Starting Current Ratio <sup>1</sup>	dB(A) <sup>2</sup>	Weight (lb)
<b>SCL e11-TD-25-3</b>	25	60	665	130	130	91.7%	208-230/460	62 / 31	12.5	85	460.8
		50	571	180	170	92.4%	200/400	69 / 34.5		83	460.8
<b>SCL e11-TD-25-3-575</b>	25	60	665	130	130	91.7%	575	24.8	12.5	85	460.8

Motors include normally closed thermal protector, 1.15 S.F. (60 Hz), tropicalized windings, Class F (B) insulation, and are suitable for use with a VFD (Contact FPZ for pneumatic and speed limits when used with a VFD).

<sup>1</sup>Starting current ratio x fla = starting current

<sup>2</sup>Noise level measured at a distance of 1 m with inlet and outlet ports piped in accordance to ISO 3744

Data is subject to change without notice.

**Recommended Accessories**

Description	Pressure Safety Valve	Vacuum Safety Valve	Pressure Filter	Vacuum Filter	Check Valve
Part number	VRL8	VRL8	FS-245P-400	CSL-2541-400I	CV40

<sup>3</sup>Valve selections are based on 60 Hz and standard air. Valves are supplied uncalibrated. Safety valves are easy to calibrate, but can be ordered with factory calibration.



### PRESSURE

### VACUUM

CAPACITY

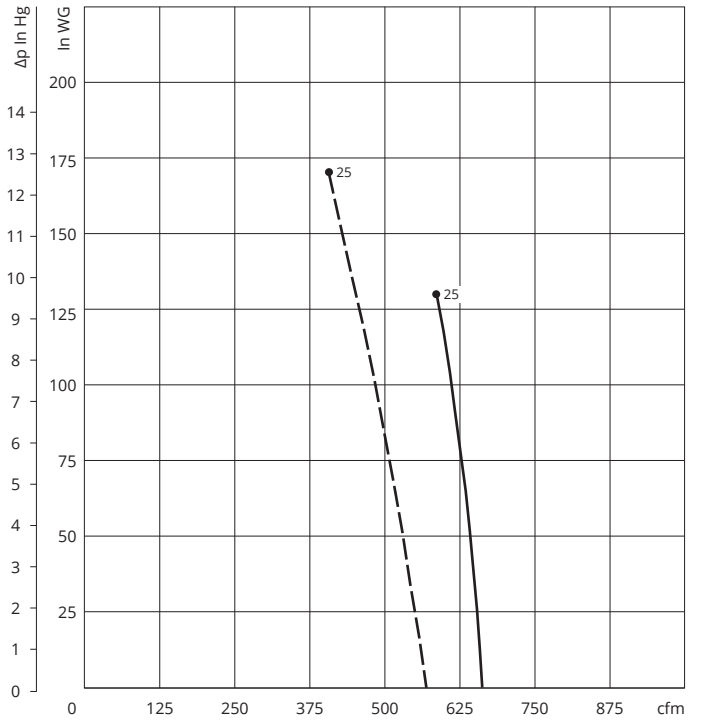
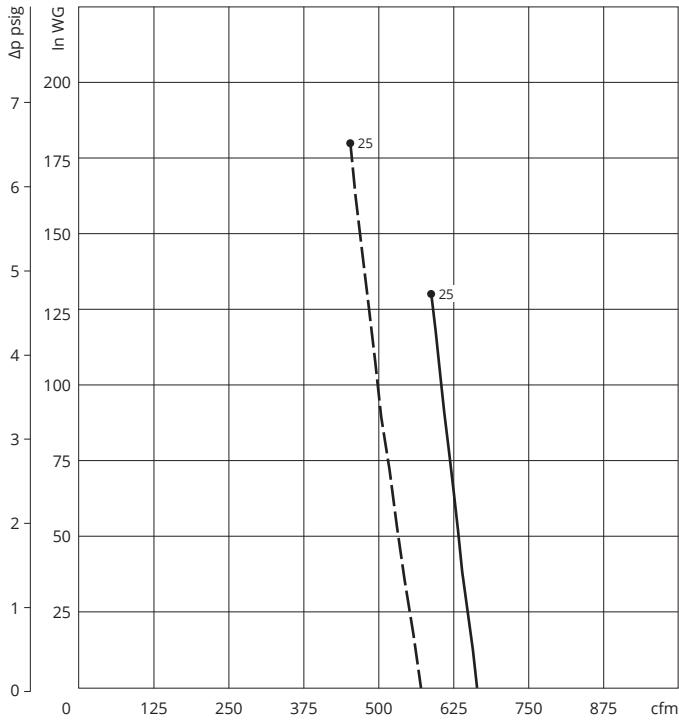

ABSORBED POWER

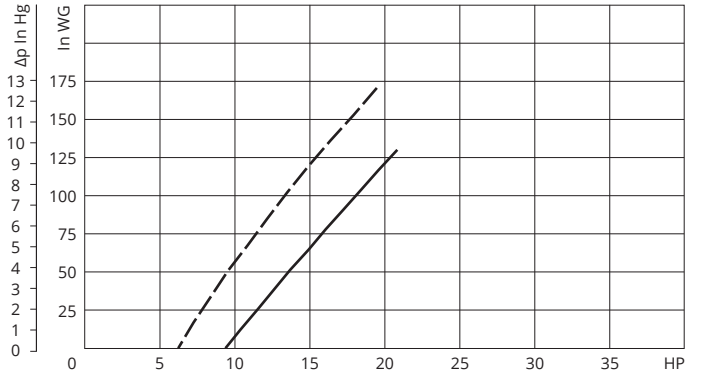
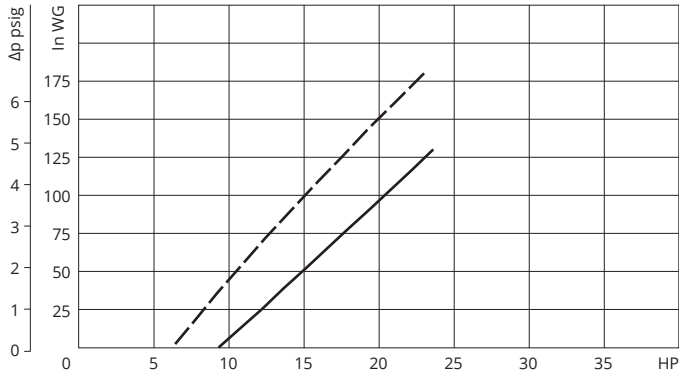

TEMPERATURE INCREASE

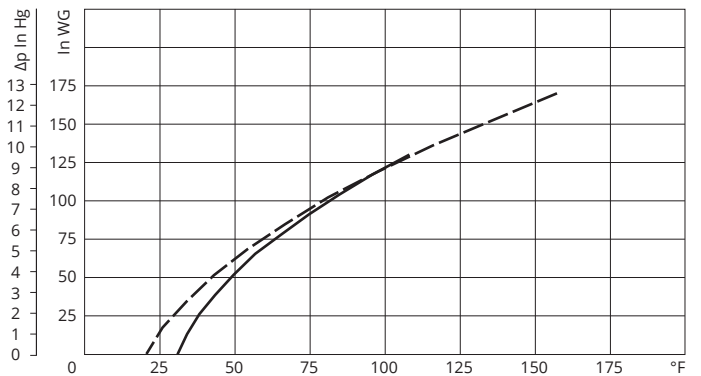
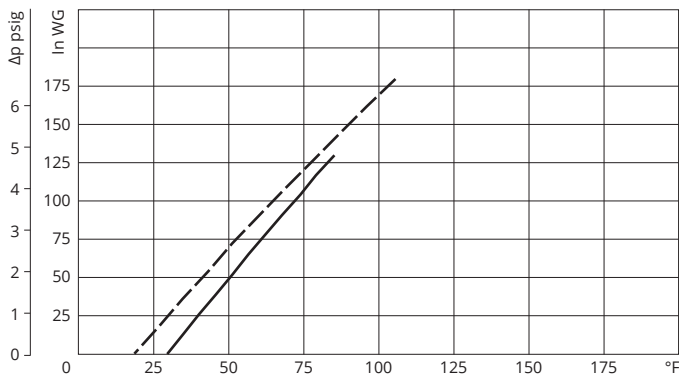

Curves refer to air at 68°F temperature and 29.92 In Hg atmospheric pressure (abs) measured at inlet port.  
Values for flow, power consumption and temperature rise: +/-10% tolerance.  
Data subject to change without notice.

<b>KEY</b>	----	50 Hz
	—	60 Hz



**Evolution Series  
Technical Characteristics**

- Premium efficient motor
- High efficiency impeller
- Mountable in any position
- Maintenance free operation
- TEFC (IP55)

**Optional Features**

- Anodized aluminum components for corrosion resistance
- Increased sealing

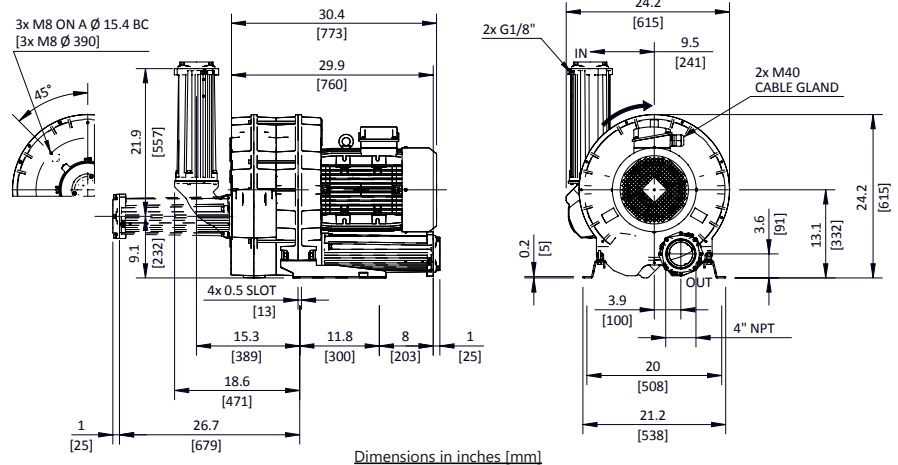

**Technical Specifications**

Model No.	HP	Hz	Open Flow (cfm)	Max Pressure in. H <sub>2</sub> O	Max Vacuum in. H <sub>2</sub> O	Efficiency	Voltage	FLA	Starting Current Ratio <sup>1</sup>	dB(A) <sup>2</sup>	Weight (lb)
<b>SCL e12-TD-30-3</b>	30	60	735	100	120	91.7%	208-230/460	71.6 / 35.3	10.6	86	309
		50	620	170	170	92.7%	200/400	77.8 / 38.9		84	309
<b>SCL e12-TD-30-3-575</b>	30	60	735	100	120	91.7%	575	28.6	10.6	86	309

Motors include normally closed thermal protector, 1.15 S.F. (60 Hz), tropicalized windings, Class F (B) insulation, and are suitable for use with a VFD (Contact FPZ for pneumatic and speed limits when used with a VFD).

<sup>1</sup>Starting current ratio x fla = starting current

<sup>2</sup>Noise level measured at a distance of 1 m with inlet and outlet ports piped in accordance to ISO 3744

Data is subject to change without notice.

**Recommended Accessories**

Description	Pressure Safety Valve	Vacuum Safety Valve	Pressure Filter	Vacuum Filter	Check Valve
Part number	VRL8	VRL8	FS-245P-400	CSL-2541-400I	CV40

<sup>3</sup>Valve selections are based on 60 Hz and standard air. Valves are supplied uncalibrated. Safety valves are easy to calibrate, but can be ordered with factory calibration.



**PRESSURE**

**VACUUM**

CAPACITY

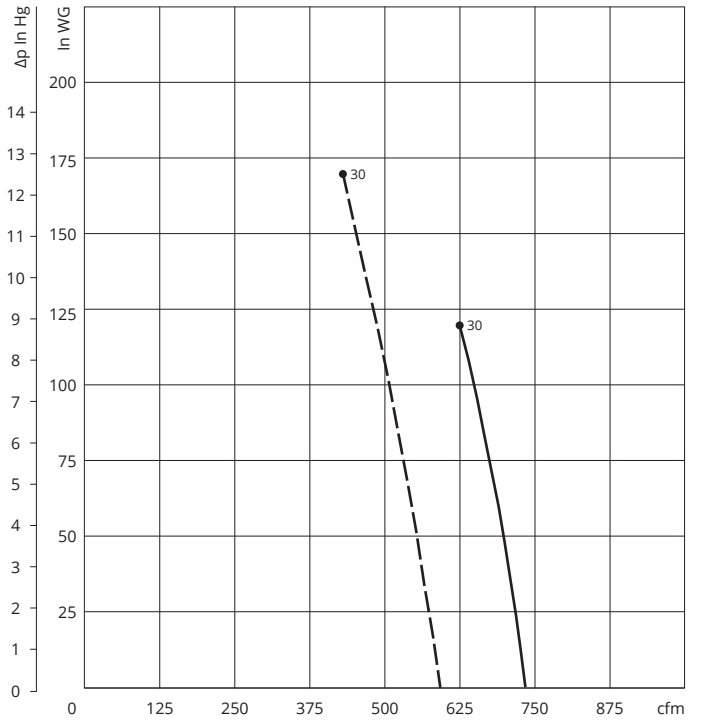
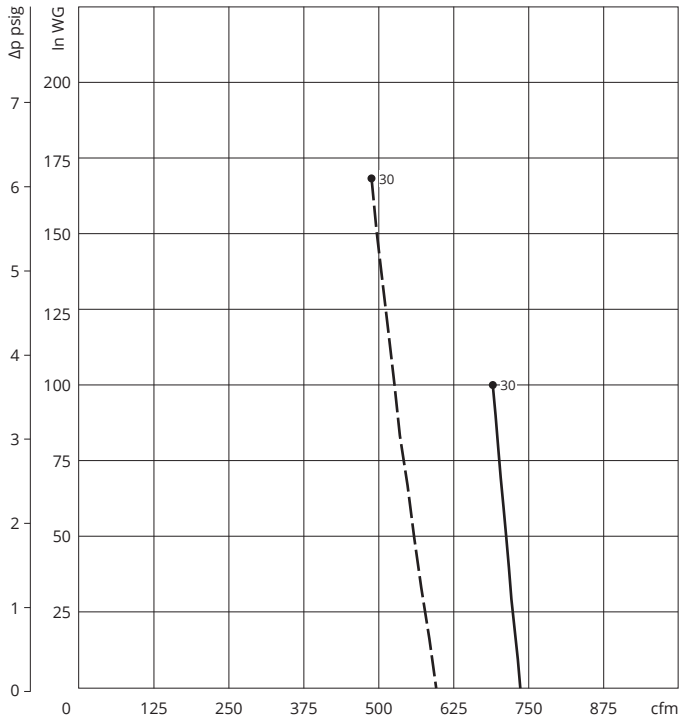

ABSORBED POWER

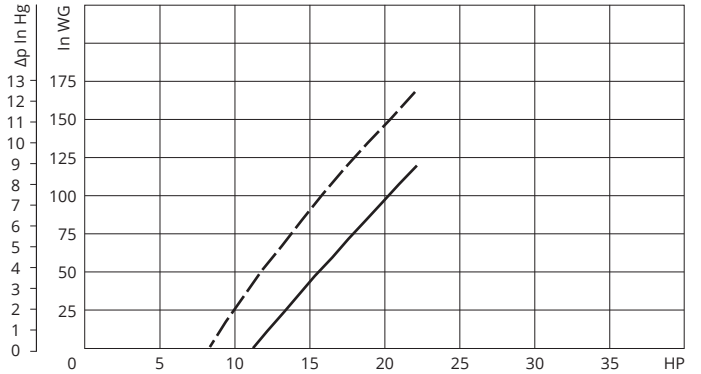
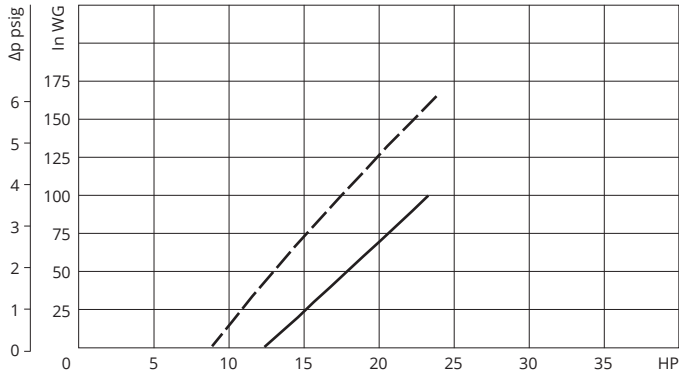

TEMPERATURE INCREASE

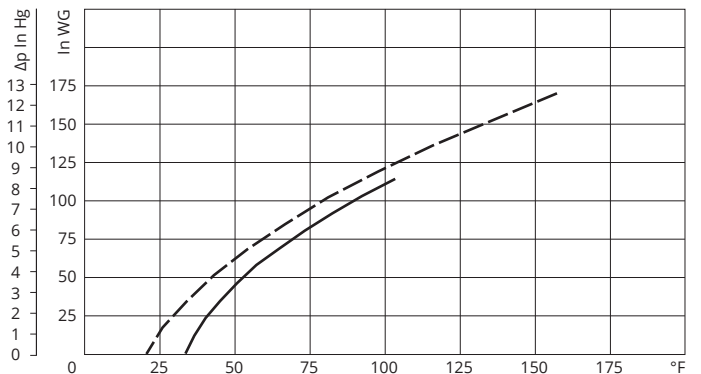
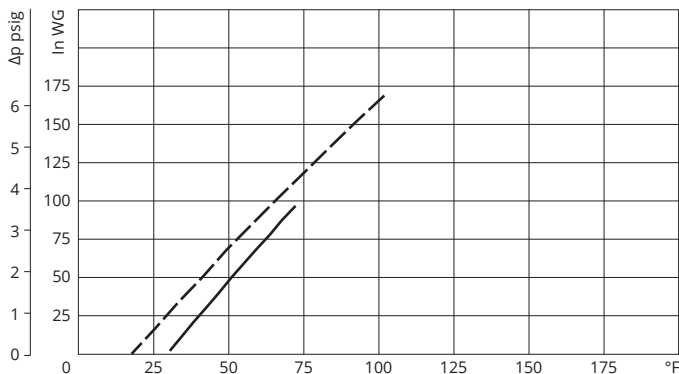

Curves refer to air at 68°F temperature and 29.92 In Hg atmospheric pressure (abs) measured at inlet port.  
Values for flow, power consumption and temperature rise: +/-10% tolerance.  
Data subject to change without notice.

**KEY**    - - - 50 Hz  
          — — — 60 Hz



**Technical Characteristics**

- Aluminium alloy construction
- Smooth operation
- High efficiency impeller
- Maintenance free
- Mountable in any position

**Options**

- Special voltages
- Surface treatments

**Accessories**

- Inlet and/or inline filters
- Additional inlet/outlet silencers
- Safety valves
- Flow converting device
- Optional connectors

**GOR Range**

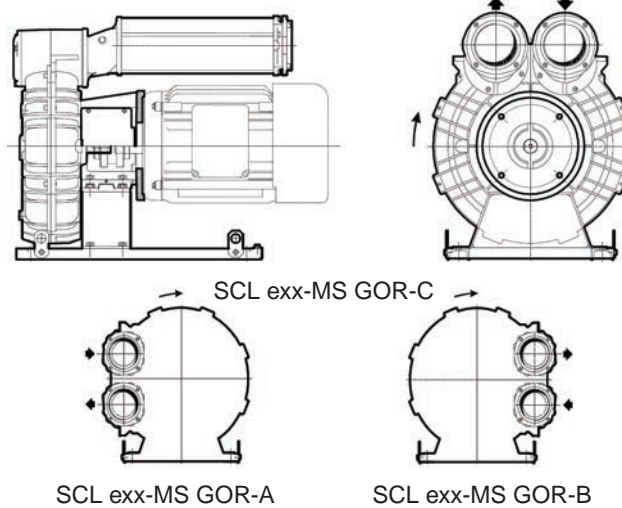

**GVR Range**

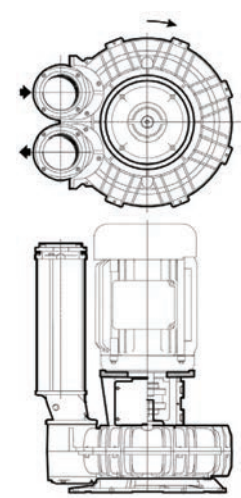

Model	Maximum Flow 60 Hz (cfm)	Installed Power (HP)	Size	Maximum Pressure 60 Hz $\Delta p$ (in WG)	Maximum Vacuum 60 Hz $\Delta p$ (in WG)	Noise Level 60 Hz $L_p$ dB (A) <sup>(1)</sup>	Weight <sup>(2)</sup> GOR / GVR (lb)
e07-MS	307	5	NEMA 182-4TC	60	70	75	143 / 120
		7 ½	NEMA 182-4TC NEMA 213-5TC	110	110		
		10	NEMA 213-5TC	160	140		
e08-MS	394	5	NEMA 182-4TC	30	35	77	155 / 131
		7 ½	NEMA 182-4TC NEMA 213-5TC	70	80		
		10	NEMA 213-5TC	110	110		
		15	NEMA 213-5TC NEMA 254-6TC	170	130		
e09-MS		7 ½	NEMA 182-4TC NEMA 213-5TC				
		10	NEMA 213-5TC				
		15	NEMA 213-5TC NEMA 254-6TC				
		20	NEMA 254-6TC				
e10-MS		7 ½	NEMA 182-4TC NEMA 213-5TC				
		10	NEMA 213-5TC				
		15	NEMA 213-5TC NEMA 254-6TC				
		20	NEMA 254-6TC				
		25	NEMA 284-6TSC				
e11-MS	639	10	NEMA 213-5TC	25	30	83.0	196 / 168
		15	NEMA 213-5TC NEMA 254-6TC	80	90		
		20	NEMA 254-6TC	120	150		
		25	NEMA 284-6TSC	150	-		
		30	NEMA 284-6TSC		-		
e12-MS	722	15	NEMA 213-5TC NEMA 254-6TC	50	60	84	198 / 170
		20	NEMA 254-6TC	90	110		
		25	NEMA 284-6TSC	130	140		
		30	NEMA 284-6TSC	170	-		

(1) Noise measured at 1 m distance with inlet and outlet ports piped in accordance to ISO 3744

(2) Value is referred to weight of the machine without electric motor



PRESSURE

VACUUM

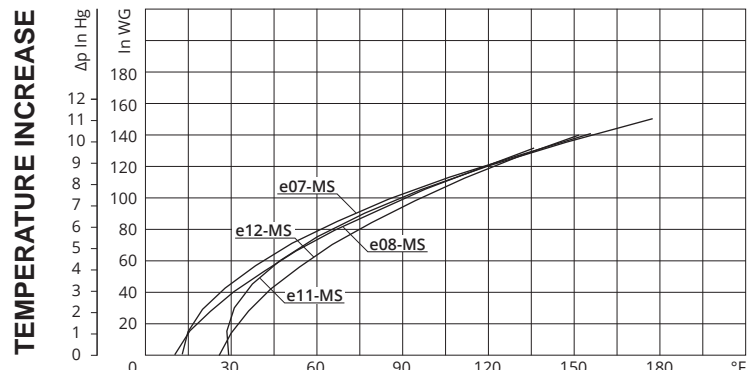
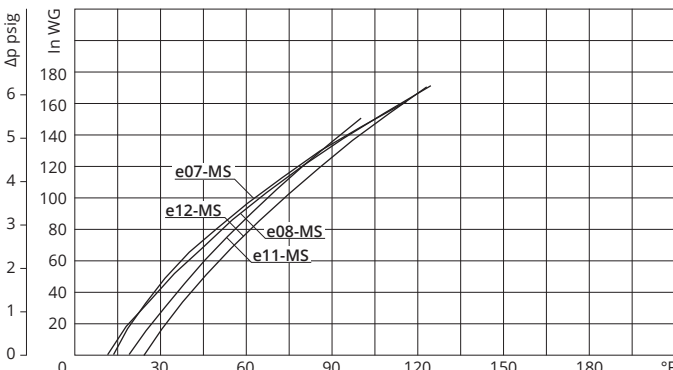
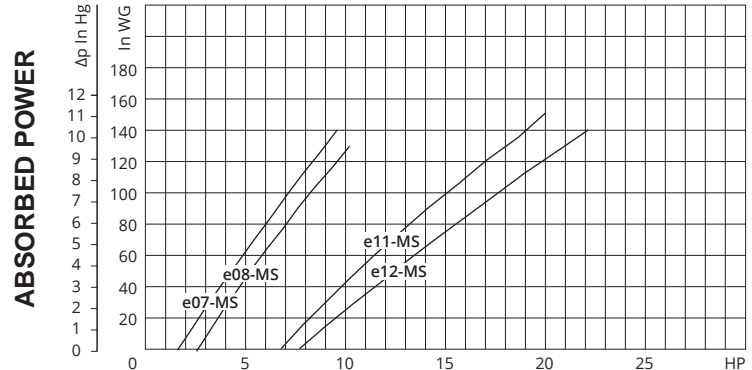
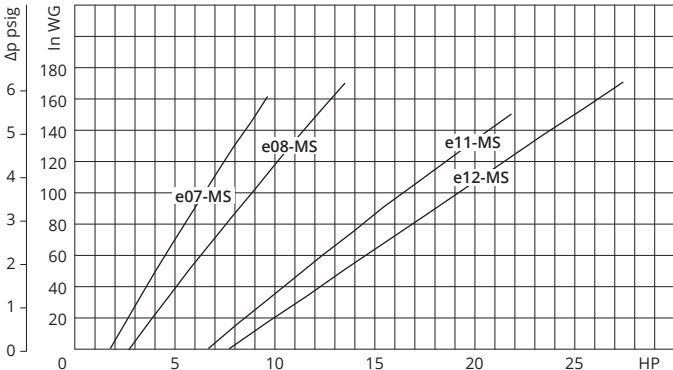
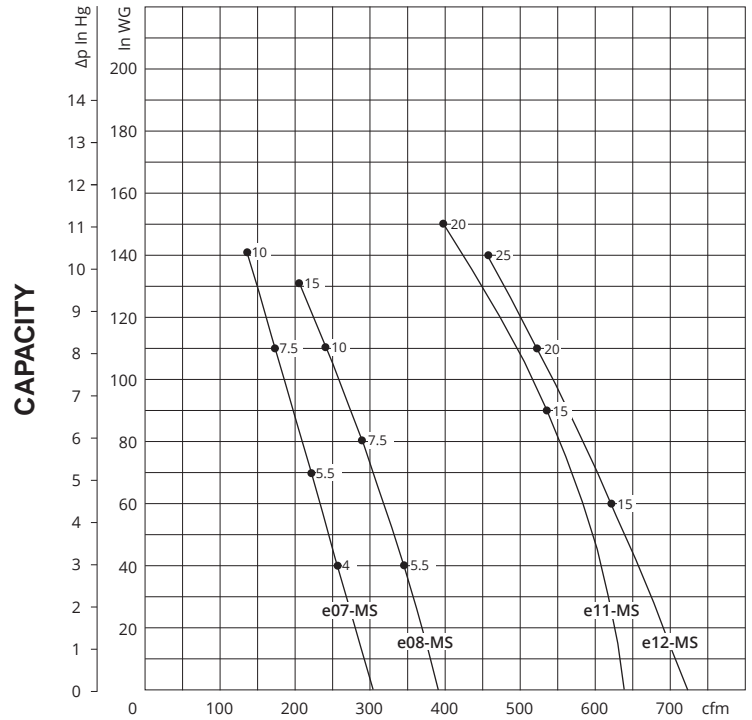
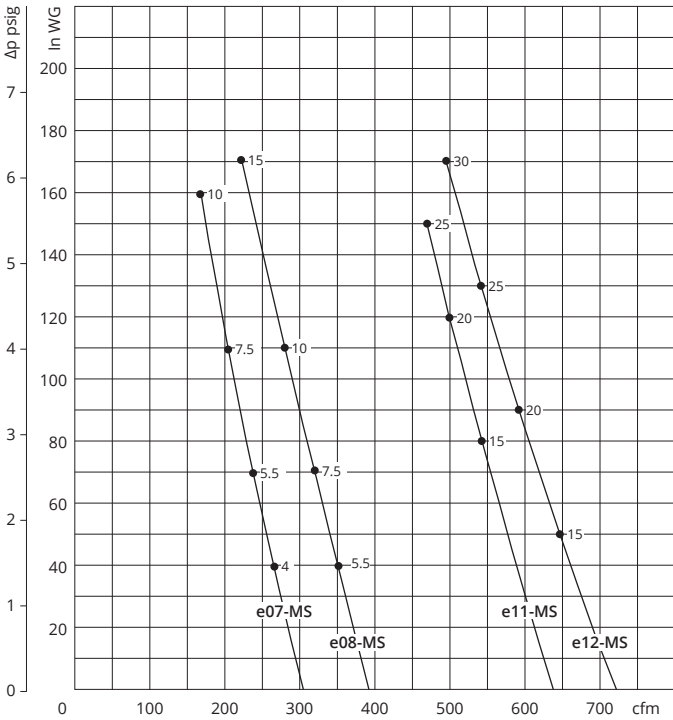

Curves refer to air at 68°F temperature and 29.92 In Hg atmospheric pressure (abs) measured at inlet port.  
 Values for flow, power consumption and temperature rise: +/-10% tolerance.  
 Data subject to change without notice.





**Technical Characteristics**

- Aluminium alloy construction
- Smooth operation
- High efficiency impeller
- Maintenance free
- Mountable in any position

**Options**

- Special voltages
- Surface treatments

**Accessories**

- Inlet and/or inline filters
- Additional inlet/outlet silencers
- Safety valves
- Flow converting device
- Optional connectors

**GOR Range**

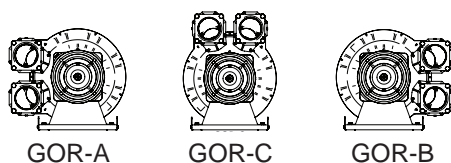
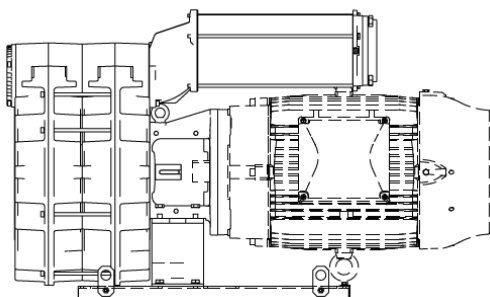

**GVR Range**

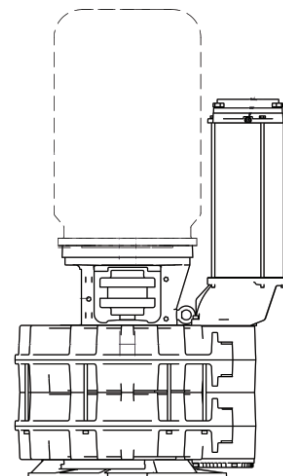

Model	Maximum Flow 60 Hz (cfm)	Installed Power (HP)	Size	Maximum Pressure 60 Hz $\Delta p$ (in WG)	Maximum Vacuum 60 Hz $\Delta p$ (in WG)	Noise Level 60 Hz Lp dB (A) <sup>(1)</sup>	Weight <sup>(2)</sup> GOR / GVR (lb)
e07-TS	582	7 ½	NEMA 182-4TC	30	30	77	206 / 184
		10	NEMA 182-4TC	50	60		
			NEMA 213-5TC				
		15	NEMA 213-5TC	100	110		
		20	NEMA 254-6TC	140	120		
e08-TS	712	15	NEMA 213-5TC	40	50	84	230 / 206
			NEMA 254-6TC				
		20	NEMA 254-6TC	90	100		
		25	NEMA 284-6TSC	130	130		
e09-TS		15	NEMA 213-5TC				
			NEMA 254-6TC				
		20	NEMA 254-6TC				
		25	NEMA 284-6TSC				
		30	NEMA 284-6TSC				
		40	NEMA 324-6TSC				
e10-TS		15	NEMA 213-5TC				
			NEMA 254-6TC				
		20	NEMA 254-6TC				
		25	NEMA 284-6TSC				
		30	NEMA 284-6TSC				
		40	NEMA 324-6TSC				
e11-TS	1264	25	NEMA 284-6TSC	50	60	86	380 / 346
		30	NEMA 284-6TSC	80	90		
		40	NEMA 324-6TSC	120	140		
		50	NEMA 324-6TSC	140	-		
e12-TS	1404	30	NEMA 284-6TSC	60	70	94	385 / 350
		40	NEMA 324-6TSC	100	110		
		50	NEMA 324-6TSC	140	120		

(1) Noise measured at 1 m distance with inlet and outlet ports piped in accordance to ISO 3744

(2) Value is referred to weight of the machine without electric motor





PRESSURE

VACUUM

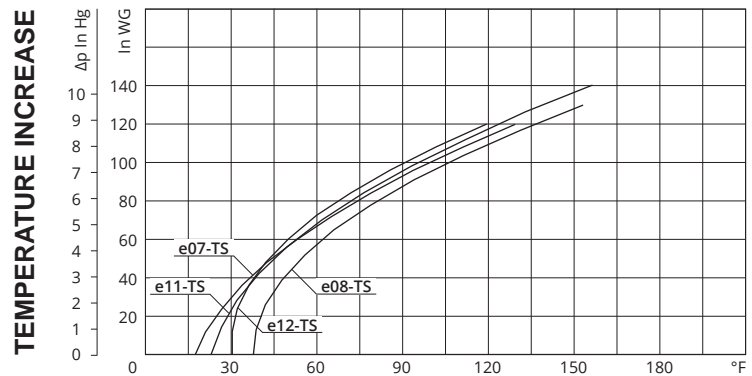
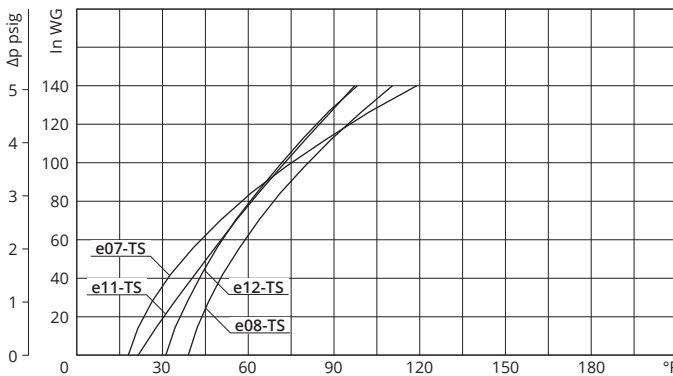
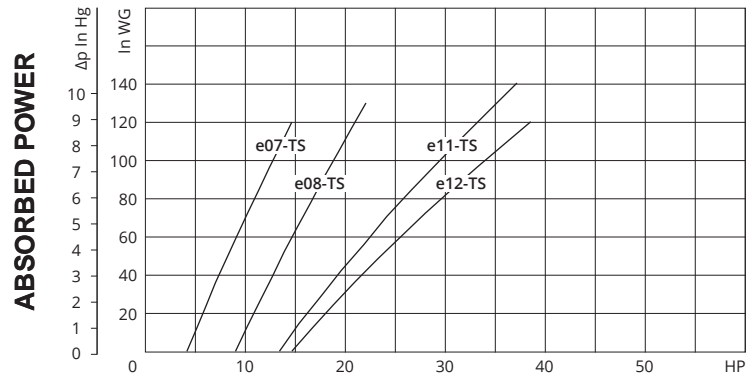
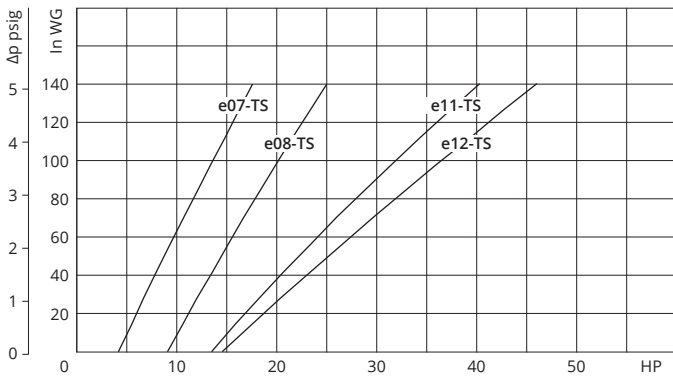
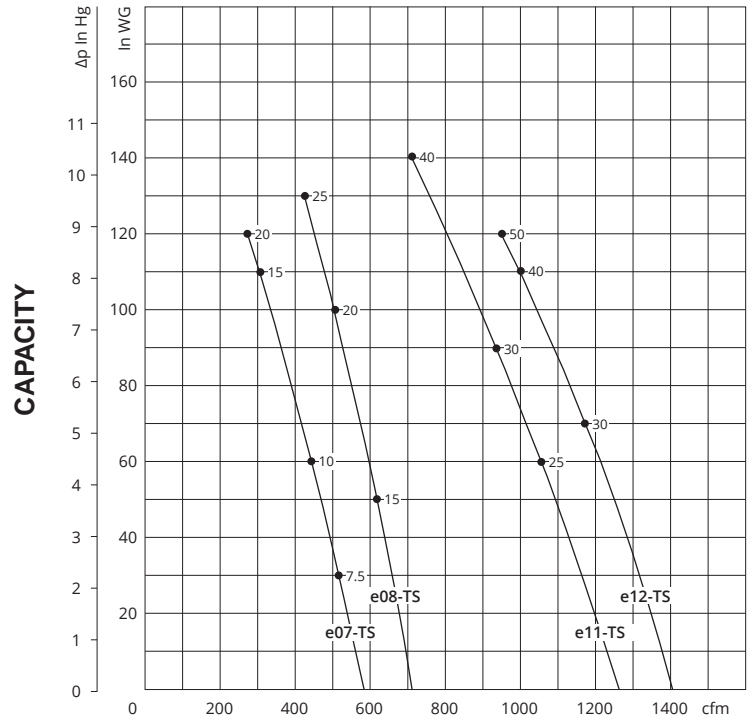
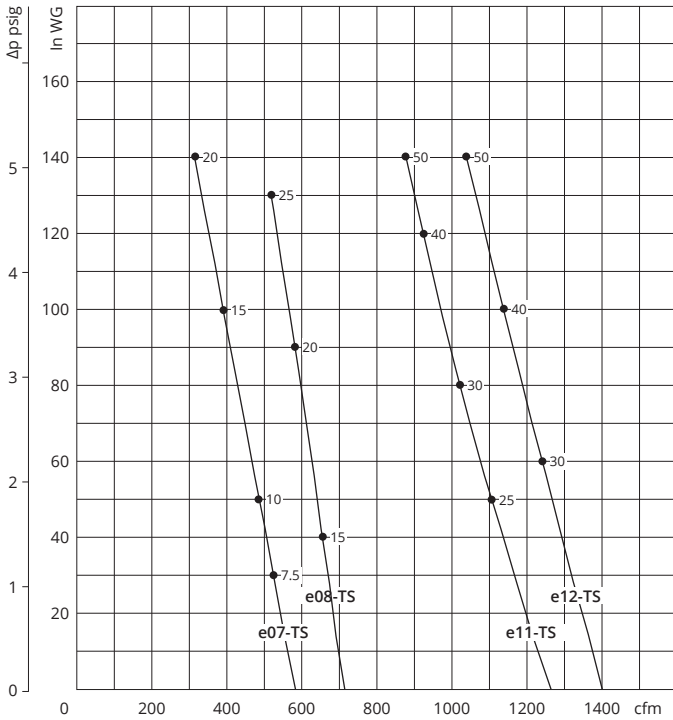

Curves refer to air at 68°F temperature and 29.92 In Hg atmospheric pressure (abs) measured at inlet port.  
 Values for flow, power consumption and temperature rise: +/-10% tolerance.  
 Data subject to change without notice.



**Technical Characteristics**

- Aluminum alloy construction
- Smooth operation
- High efficiency impeller
- Maintenance free
- Mountable in any position

**Accessories**

- Inlet and/or inline filters
- Additional inlet/outlet silencers
- Safety valves
- Flow converting device
- Optional connectors

**Options**

- Special voltages
- Surface treatments

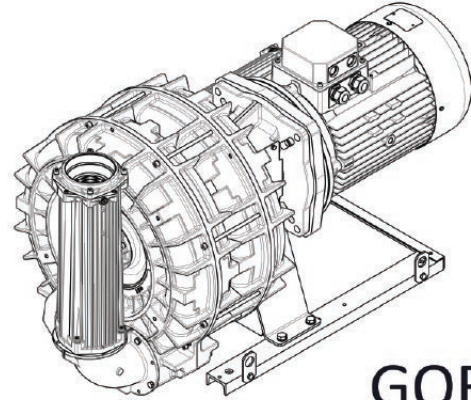

**GOR**

Model	Maximum Flow 60 Hz (cfm)	Installed Power (HP)	Size	Maximum Pressure 60 Hz $\Delta p$ (in WG)	Maximum Vacuum 60 Hz $\Delta p$ (in WG)	Noise Level 60 Hz Lp dB (A) <sup>(1)</sup>	Weight <sup>(2)</sup> GOR / GVR (lb)
e07-TD	304	7 ½	NEMA 182-4TC	80	90	77	204
			NEMA 213-5TC	130	140		
		10	NEMA 213-5TC				
		15	NEMA 213-5TC				
			NEMA 254-6TC				
20	NEMA 254-6TC	240	-				
e08-TD	406	10	NEMA 213-5TC	60	80	78	226
		15	NEMA 213-5TC	140	160		
			NEMA 254-6TC				
20	NEMA 254-6TC	210	-				
e09-TD		15	NEMA 213-5TC				
			NEMA 254-6TC				
		20	NEMA 254-6TC				
		25	NEMA 284-6TSC				
30	NEMA 284-6TSC						
e10-TD		15	NEMA 213-5TC				
			NEMA 254-6TC				
		20	NEMA 254-6TC				
		25	NEMA 284-6TSC				
		30	NEMA 284-6TSC				
40	NEMA 324-6TSC						
e11-TD	665	20	NEMA 254-6TC	80	110	85	307
		25	NEMA 284-6TSC	130	160		
		30	NEMA 284-6TSC	170	-		
		40	NEMA 324-6TSC	240	-		
e12-TD	735	25	NEMA 284-6TSC	100	130	86	309
		30	NEMA 284-6TSC	140	170		
		40	NEMA 324-6TSC	220	-		
		50	NEMA 324-6TSC	240	-		

(1) Noise measured at 1 m distance with inlet and outlet ports piped in accordance to ISO 3744

(2) Value is referred to weight of the machine without electric motor



PRESSURE

VACUUM

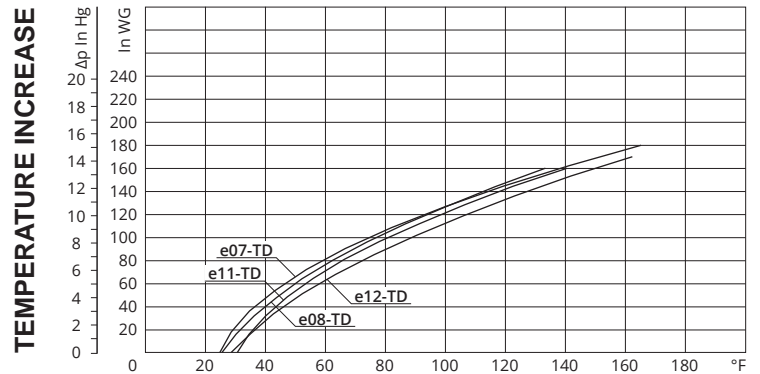
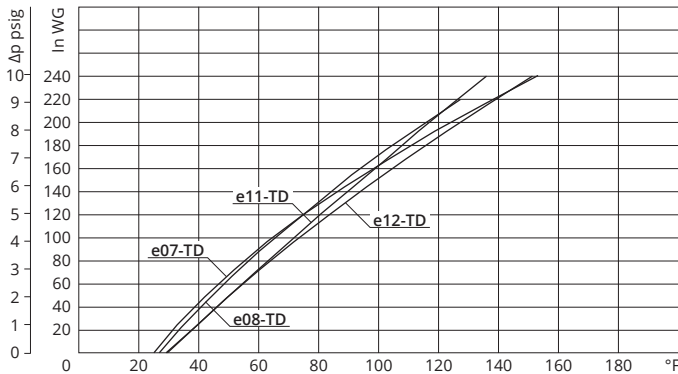
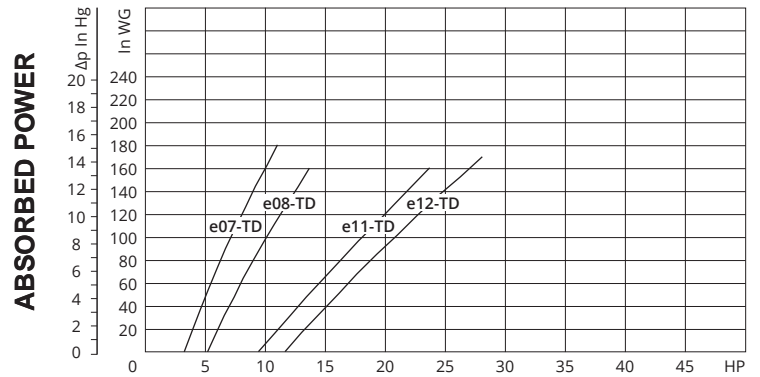
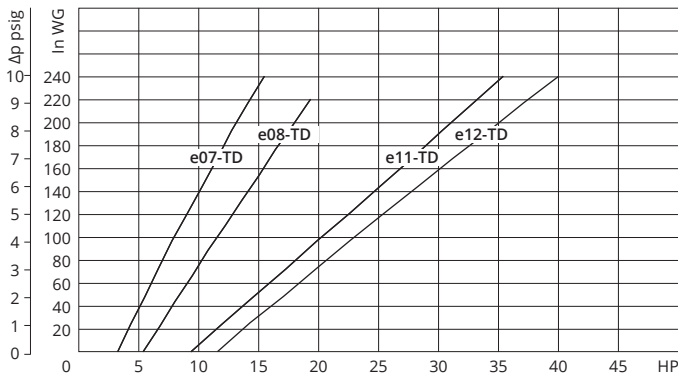
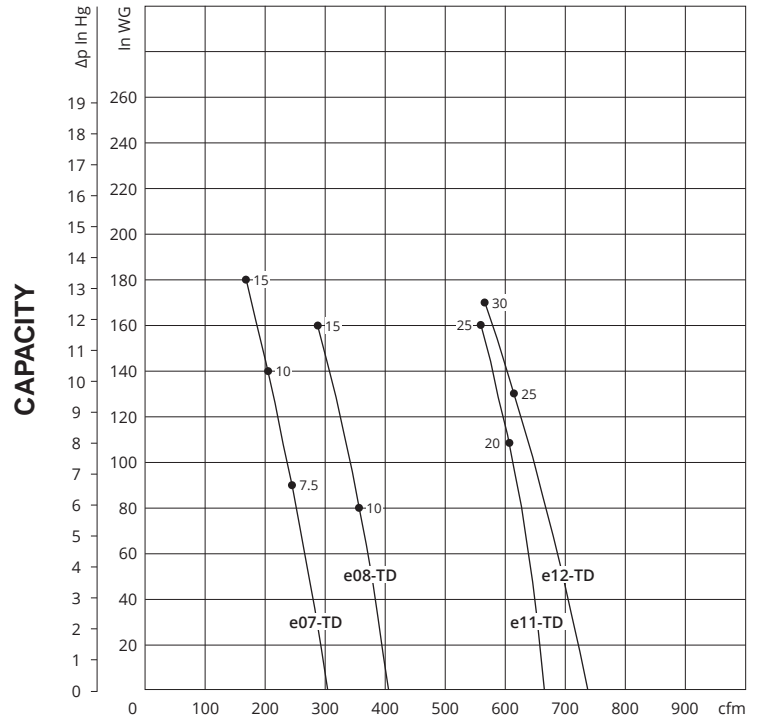
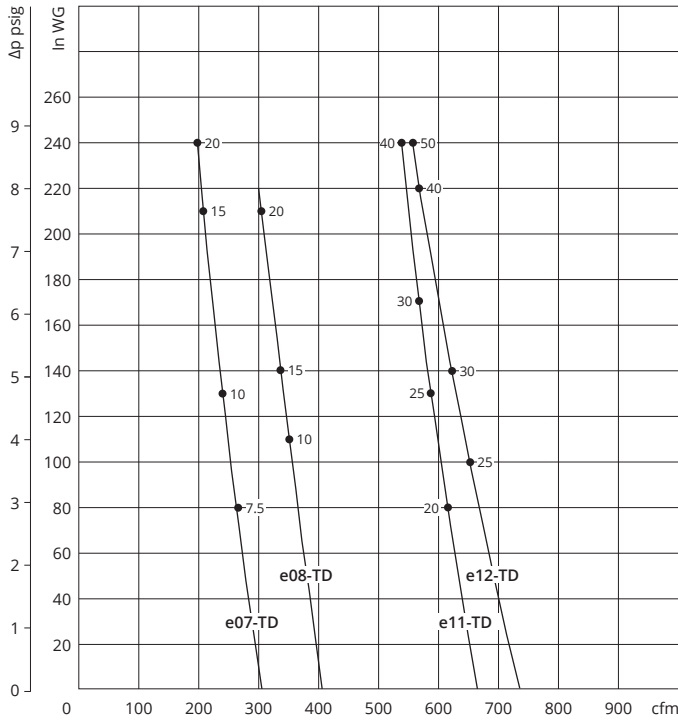

Curves refer to air at 68°F temperature and 29.92 In Hg atmospheric pressure (abs) measured at inlet port.  
 Values for flow, power consumption and temperature rise: +/-10% tolerance.  
 Data subject to change without notice.

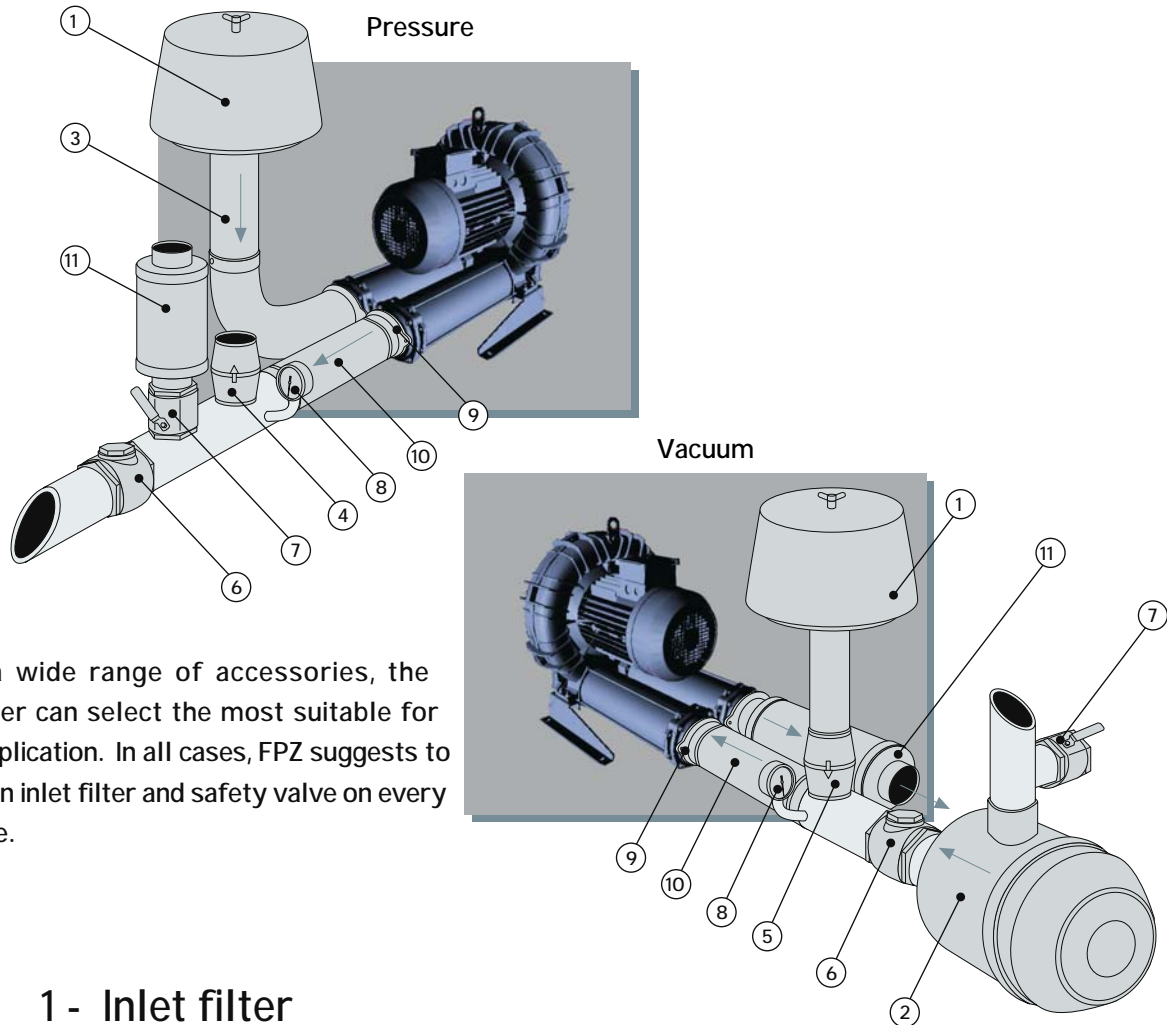

From a wide range of accessories, the customer can select the most suitable for their application. In all cases, FPZ suggests to install an inlet filter and safety valve on every machine.

- 1 - Inlet filter
- 2 - Inline filter
- 3 - Filter manifold
- 4 - Safety valve (pressure)
- 5 - Safety valve (vacuum)
- 6 - Check valve
- 7 - Ball valve (used to control flow by bleeding air)
- 8 - Pressure / Vacuum gauge
- 9 - Sleeve (for hose connection)
- 10 - Flexible hose
- 11 - Additional silencer



# Gauges, Check Valves, Silencers, Enclosures

SS2401

## Gauges

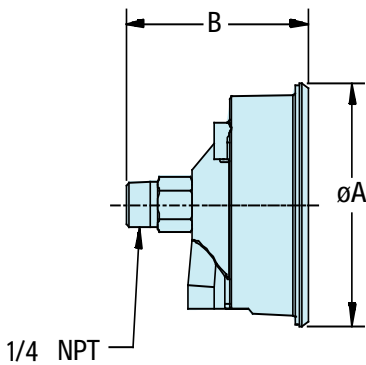

Gauges are important for monitoring the operating pressure or vacuum of the blower. Gauges should be positioned as close to the blower as possible.

Part number	Duty	Scale	A	B
VG25-60	Vacuum	0-60" H <sub>2</sub> O	2.88	2.59
VG25-200	Vacuum	0-200" H <sub>2</sub> O		
VG25-300	Vacuum	0-300" H <sub>2</sub> O		
PG25-60	Pressure	0-60" H <sub>2</sub> O		
PG25-200	Pressure	0-200" H <sub>2</sub> O		
PG25-300	Pressure	0-300" H <sub>2</sub> O	2.7	2.25
PG25-15*	Pressure	0-15 psi		

Dimensions in inches. Tolerance on given values ± 10% - unbinding and can be changed without prior notice.

\*PG25-15 is suitable for outdoor use

## Check Valves

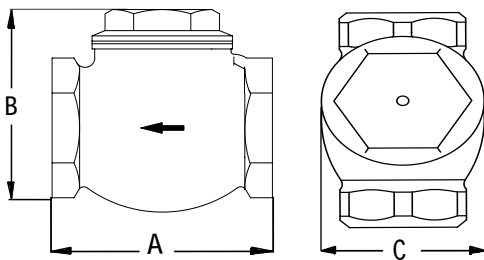

Swing check valves allow air to flow in one direction. These valves prevent backflow into the blower and are supplied in bronze or brass.

Part Number	NPT	A	B	C
CV075	0.75"	2.4		
CV10	1"	2.8	2.7	1.9
CV125	1.25"	3.2	3.2	2.2
CV15	1.5"	3.6	3.5	2.5
CV20	2"	4.3	4.2	3.1
CV30	3"	5.8	6.1	4.2
CV40	4"	6.9	7.1	5.5

Dimensions in inches. Tolerance on given values ± 10% - unbinding and can be changed without prior notice.

## Silencers

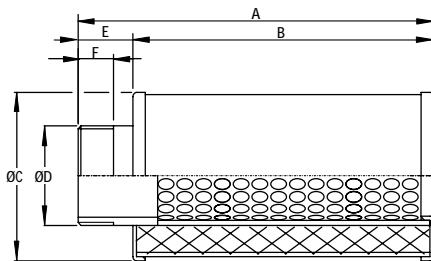

Silencers provide additional sound attenuation.

TYPE	D	A	B	C	E	F	lbs
SS 4	1" 1/4	7.5	5.5	2.8	2	0.6	0.8
SS 5	1" 1/2	7.9	6.7	3.1	1.2	0.8	1.1
SS 6	2"	9.1	7.9	3.5	1.2	0.8	1.3
SS 8	3"	19.1	15.7	6.0	3.3	0.8	4.8
SS 9	4"	18.3	16.9	6.7	1.1	0.8	9.9

Steel manufactured (apart from SI 9 / SS 9 - entirely in aluminium) with sound absorbing polyurethane element.

Dimensions in inches. Tolerance on given values ± 10% - unbinding and can be changed without prior notice.

## Sound Enclosures

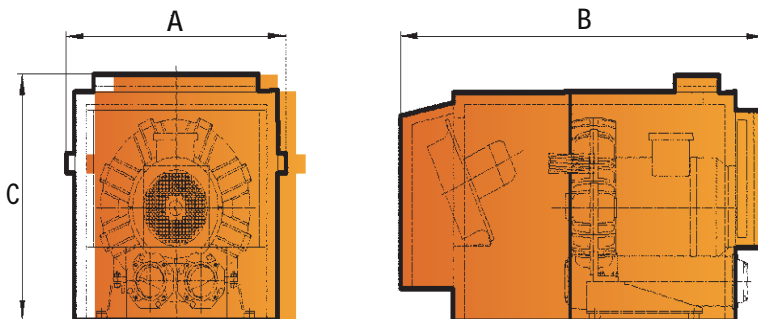

Part #	Used on models	A	B	C
IH1	SCL K03-MS	13.4	18.2	15.8
IH3	SCL K04-MS	14.3	19.7	16.5
IH4	R20-40 MD	16.9	26.8	21.6
IH5	SCL K05-6 MS	16.9	26.8	21.6
255C6M-2	SCL e/K07-8 MD	25.1	29.7	27.6
255C6M-3	SCL K05-6 TD	23.1	35.6	23.3
255C8M-1	SCL e/K7-8 MS + SCL K05-6 TS	25.1	41.5	27.6
255C8M-2	SCL e/K07-8 TD	25.1	41.5	27.6
255C9M-1	SCL e/k9-12 MS/MD SCL e/K07-8TS	33.5	49.6	32.4
255C9M-2	SCL e/K09-12 TD	33.5	49.6	32.4
255C10M	SCL e/K09-12 TS	33.5	49.6	32.4

Dimensions in inches - unbinding and can be changed without prior notice.



# ACCESSORIES Safety Valves

SS2407

The following table is a guide to select the appropriate safety valve. The selections in the table are based on blowers operating at **60 Hz** - for 50 hz applications refer to the safety valve data sheets. To select the appropriate safety valve, determine the blower model, horsepower, and whether it is to be used for vacuum or pressure service. If it is desirable to have the valve activate at lower pressures than the maximum rated pressure or vacuum of the blower, a different safety valve might be required (refer to safety valve data sheets). In some cases, two valves are required. **FPZ valves are supplied uncalibrated.** All safety valves include detailed instructions on how to calibrate and install the valve.

Single Stage Blowers			
Model	HP	Safety Valve Vacuum	Safety Valve Pressure
K03-MS	3/4	VRL6	VRL6
K04-MS	ALL	VRL6	VRL6
K05-MS	ALL	VRL6	VRL6
K06-MS	3	VRL6	VRL8
K06-MS	4	VRL6	VRL6
K06-MS	5 1/2	VRL6	VRL6
K06-MS	6 1/5	VRL6	VRL6
e07-MS	4	VRL8	VRL8
e07-MS	5 1/2	VRL6	VRL8
e07-MS	7 1/2	VRL6	VRL6
e07-MS	10	VRL6	VRL6
e08-MS	5.5	VRL8	VRL9
e08-MS	7 1/2	VRL8	VRL8
e08-MS	10	VRL6	VRL8
e08-MS	15	VRL6	VRL6
K09-MS	7 1/2	VRL9	VRL9
K09-MS	10	VRL8	VRL8
K09-MS	15	VRL6	VRL8
K09-MS	20	VRL6	VRL6
K10-MS	7 1/2	VRL9	VRL9
K10-MS	10	VRL9	VRL9
K10-MS	15	VRL8	VRL8
K10-MS	20	VRL8	VRL8
K10-MS	25	-	VRL6
e11-MS	15	VRL9	VRL9
e11-MS	20	VRL8	VRL8
e11-MS	25	-	VRL8
e12-MS	15	VRL9	VRL9
e12-MS	20	VRL9	VRL9
e12-MS	25	VRL8	VRL8
K05-TS	5.5	VRL8	VRL8
K06-TS	5 1/2	VRL9	VRL9
K06-TS	7 1/2	VRL8	VRL8
K06-TS	10	VRL6	VRL8
e07-TS	7 1/2	VRL9	VRL9
e07-TS	10	VRL9	VRL9
e07-TS	15	VRL8	VRL8
e08-TS	15	VRL9	VRL9

Single Stage Blowers			
Model	HP	Safety Valve Vacuum	Safety Valve Pressure
K09-TS	20	VRL9	VRL9
K09-TS	25	VRL8	VRL9
K10-TS	20	(2) VRL9	(2) VRL9
K10-TS	25	VRL9	VRL9
e11-TS	25	(2) VRL9	(2) VRL9
e11-TS	30	(2) VRL9	(2) VRL9
e12-TS	30	(3) VRL9	(3) VRL9
Two Stage Blowers			
Model	HP	Safety Valve Vacuum	Safety Valve Pressure
15DH	ALL	VRL6	VRL6
R20-MD	ALL	VRL6	VRL6
R30-MD	ALL	VRL6	VRL6
R40-MD	ALL	VRL6	VRL6
e07-MD	5 1/2	VRL6	VRL6
e07-MD	7.5	VRL6	VRL6-HP
e07-MD	10	VRL6-HP	VRL6-HP
e08-MD	5 1/2	VRL6	VRL6
e08-MD	7 1/2	VRL6	VRL6
e08-MD	10	VRL6	VRL6
e08-MD	15	-	VRL6-HP
K09-MD	10	VRL6	VRL6
K09-MD	15	-	VRL6-HP
K10-MD	10	VRL6	VRL6
K10-MD	15	VRL6	VRL6
K10-MD	20	-	VRL6-HP
e11-MD	15	VRL6	VRL8
e11-MD	20	VRL6	VRL6-HP
e12-MD	15	VRL8	VRL8
e12-MD	20	VRL6	VRL8
e12-MD	25	-	VRL6
K05-TD	5 1/2	VRL6	VRL6
K06-TD	10	VRL6	VRL6
K07-TD	15	VRL6	VRL6
K08-TD	15	VRL6	VRL6
K09-TD	25	VRL6	VRL6
K10-TD	25	VRL6	VRL8
e11-TD	25	VRL8	VRL8
e12-TD	30	VRL8	VRL8

Valve selections are based on 60 Hz operation and refer to air having a density equal to 0.075 lbs / cu. Ft and inlet temperature of 68 deg F. Data is subject to change without notice





The VRL valves are designed to protect blowers and / or motors from over pressurization or excess vacuum. When there is over pressurization, the valve opens and discharges to the outside. When there is excess in vacuum, the valve opens and takes flow from outside.

The valves have been designed for low pressure / low vacuum, with minimal difference between the initial value at which the valve begins to open and its fully opened position. The valves are supplied with 2 different springs to maximize their efficiency. These compact valves, made of aluminum alloy, are both easy to install and calibrate, and operate in a wide range of capacities. The VRL can be plumbed to divert excess primary flow through a secondary external outlet when working in pressure conditions, or to pipe in a secondary flow when working in vacuum. "HP" valves are used for pressures >240" H2O.

Maximum efficiency is achieved by keeping operating values (flow versus pressure or vacuum) within the operating range (shaded area on graph). Capacity refers to air having a density equal to 0.075 lbs./cu.ft .



VRL6  
VRL6 HP

VRL8  
VRL8 HP

VRL9

**OPERATING RANGE**

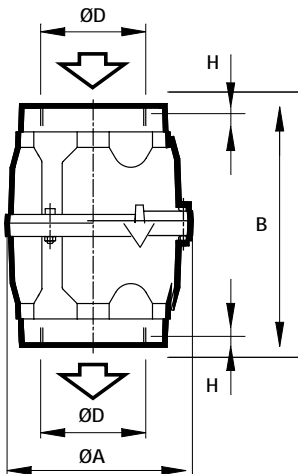
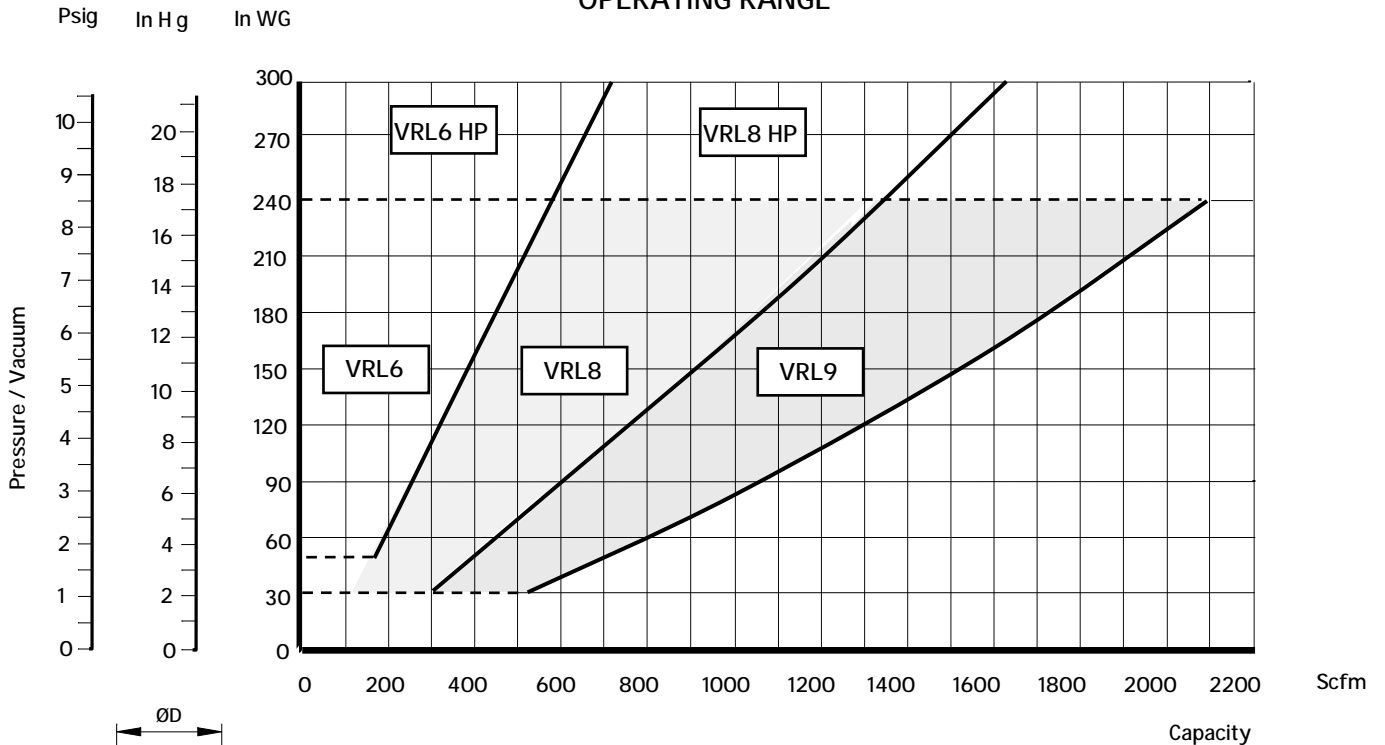

**OVERALL DIMENSIONS**

TYPE	ND	D	A	B	H	WEIGHT (Lbs)
VRL6 & VRL6 HP	2"	2" NPT	4.02	6.90	0.47	1.9
VRL8 & VRL8HP	3"	3" NPT	5.31	7.48	0.59	4.2
VRL9	4"	4" NPT	6.30	8.11	0.71	5.7

- Dimensions in inches.
- Specifications subject to change without prior notice.

VRL valves are supplied uncalibrated - contact FPZ for calibration options.



FPZ inline filters are typically used in vacuum applications to prevent debris from entering the blower. Inline filters consist of a metal housing with a metal cover retained by quick - change clamps for easy servicing of the element. Polyester elements are recommended for humid applications.

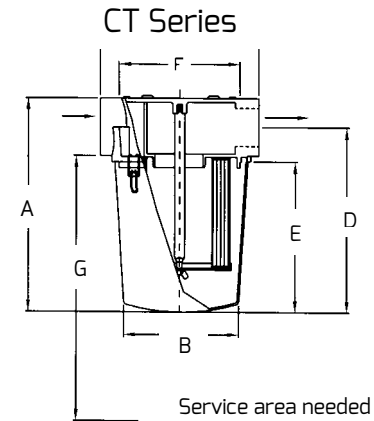
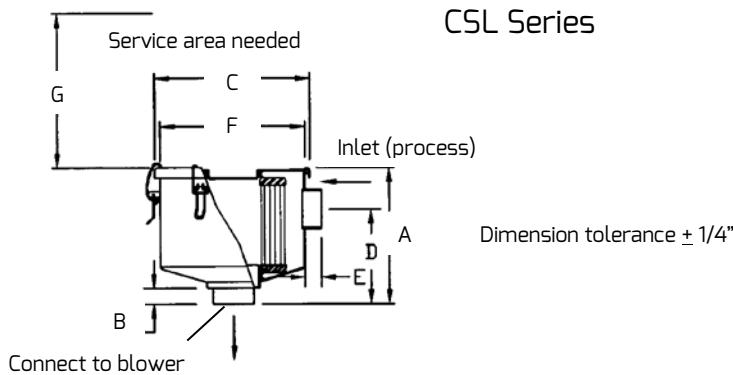

- ♦ Polyester: 99%+ removal efficiency standard to 5 micron
- ♦ Stainless steel torsion clips for durability
- ♦ Rugged construction with powder coated finish
- ♦ Low pressure drop
- ♦ Positive sealing O-ring seal system
- ♦ Large dirt holding capacity and easy field cleaning, (especially when mounted horizontally or inverted)
- ♦ Fully-drawn one piece canister
- ♦ Filter change out differential: 10"-15" H<sub>2</sub>O Over Initial Delta P

- ♦ Various media available
- ♦ Epoxy coated housings
- ♦ Special connections
- ♦ Available in Stainless Steel
- ♦ Activated carbon prefilter to reduce odor
- ♦ Alternate Top-to-canister fastening system for low pressure or pulsating systems

Polyester Element	NPT	DIMENSIONS (Inches)							Used on Models	Approx Wt. Lbs
		A	B	C	D	E	F	G		
CSL-843-050HC	1/2"	4 3/8	9/16	5 7/8	2 1/2	9/16	5	3 1/4	10DL	3
CSL-843-075HC	3/4"	4 3/8	9/16	5 7/8	2 1/2	9/16	5	3 1/4	15DH	3
CSL-843-100HC	1"	4 3/8	3/4	5 7/8	2 1/2	3/4	5	3 1/4	06	3
CSL-843-125HC	1 1/4"	4 3/8	3/4	5 7/8	2 1/2	3/4	5	3 1/4	K03-MS, R20-MD	3
CSL-849-125HC	1 1/4"	6 3/4	3/4	7 5/16	4 1/2	3/4	6 13/16	5 1/4	R30-MD, R40-MD	5
CSL-849-150HC	1 1/2"	6 3/4	3/4	7 5/16	4 1/2	3/4	6 13/16	5 1/4	K04-MS	5
CSL-851-200HC	2"	10 1/4	3/4	8 3/4	5	3/4	7 5/8	9 1/4	K05-MS, K06-MS, K05-TD, K06-TD, e07-MD, e08-MD	15
CT-235P-300C	3"	18 13/16	9 7/8	13 1/2	16 4/5	13 1/8	10	14	K05-TS, K06-TS, e07-MS, e08-MS, e07-TD, e08-TD	30
CT-235P-400C	4"	18 13/16	9 7/8	13 1/2	16 4/5	13 1/8	10	14	K09-MS, K10-MS, K09-MD, K10-MD, e11-MD, e12-MD, K09-TD, K10-TD	29
CSL-2541-400I*	4"	16 3/8	3 5/8	13 1/4	9 1/2	3 1/2	12 1/16	8	e07-TS, e08-TS, e11-MS, e12-MS, e11-TD, e12-TD	38
CT-275P-500C	5"	18 1/4	16	19	14 3/8	9 7/8	14 3/4	20	K09-TS, K10-TS	50
CTD-375P-500C	5"	25 3/8	16	19	21 1/2	17	14 3/4	35	e11-TS, e12-TS	60

\* Male x male npt connections  
 Dimensions for reference only





FPZ inlet filters are used for pressure applications. The inlet filters combine filtration and sound attenuation into a compact package. Inlet filters consist of a filter cartridge enclosed by a carbon steel weather hood. Elements are easily serviceable by simply removing the weather hood.

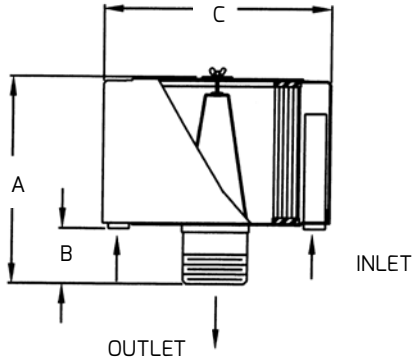

Dimension tolerance  $\pm 1/8"$



VG-020-013

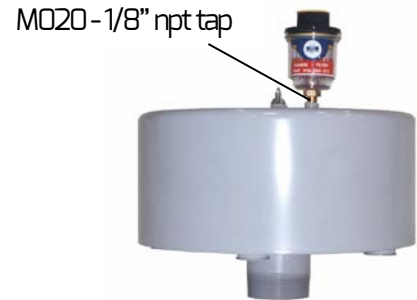

**FEATURES & SPECIFICATIONS**

- Polyester: 99%+ removal efficiency standard to 5 micron. (Other media available upon request.)
- Fully drawn weather hood - no welds to rust or vibrate apart
- Tubular silencing design - tube is positioned to maximize sound attenuation and air flow while minimizing pressure drop
- Durable carbon steel construction with baked enamel finish
- Filter change out differential: 10"-15" H<sub>2</sub>O Over Initial Delta P.

**OPTIONAL DIRTY FILTER INDICATOR**

The VG-020-013 dirty filter indicator is used to maximize filter life for pressure applications only. The yellow indicator in the site window drops as dirt accumulates on the filter element. The element is ready for change out or servicing when the yellow indicator reaches the red zone. The filter condition can be determined without removing the weather hood even after the blower has been shut down.

The indicator can be mounted in the inlet piping between the blower and filter or directly to the filter housing by having a 1/8" npt tap installed in the hood. If a tap is required, FPZ part number MO20\* should be ordered.

Polyester Element	NPT	Dimensions (Inches)			Used on Models	Approx Wt. Lbs
		A	B	C		
FS-15-050	1/2"	4	1 1/2	6	10DL	2
FS-15-075	3/4"	4	1 1/2	6	15DH	2
FS-15-100	1"	4	1 1/2	6	06	2
FS-19P-125	1 1/4"	6 5/8"	1 5/8"	6	K03-MS, R20-MD, R30-MD, R40-MD	3
FS-19P-150	1 1/2"	6 5/8"	1 5/8"	6	K04-MS	4
FS-31P-200	2"	7 1/4"	2 1/4"	10	K05-MS, K05-TD	8
FS-231P-200	2"	12 1/4"	2 1/4"	10	K06-MS, K06-TD, e07-MD, e08-MD	14
FS-231P-300	3"	13"	3"	10"	e07-MS, K05-TS, e07-TD	15
FS-235P-300	3"	13"	3"	16"	e08-MS, K06-TS, e08-TD	29
FS-235P-400	4"	14"	4"	16"	K09-MS, K10-MS, K09-MD, K10-MD, e11-MD, e12-MD, K09-TD, K10-TD	30
FS-245P-400	4"	14"	4"	16"	e07-TS, e08-TS, e11-MS, e12-MS, e11-TD, e12TD	31
FL10**	NA	14 3/8"	1 3/8"	16 3/16"	K09-TS, K10-TS, e11-TS, e12-TS,	18

\*MO20 1/8" npt filter tap will be added to filter part number suffix if ordered.

\*\*FL10 utilizes 15 micron paper element and does not include tubular silencers. FL10 filters are normally ordered with CA10 manifold



# ACCESSORIES VK / PK Flange Connectors

SN 2048-3

## VK - FLANGE CONNECTOR FOR VRL VALVES

This VK flange accessory allows direct connection of the VRL relief valves to the cover of the SCL "K" model blowers; either in pressure or vacuum.

Note: VK flanges usable on K-MS and K-TS blowers in vacuum or pressure K-MD useable in vacuum only.

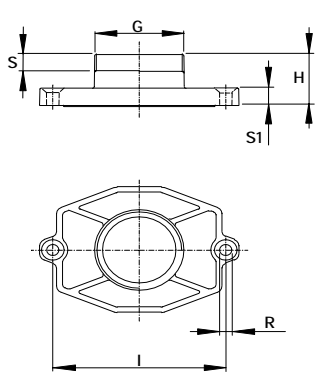

Fig. 1

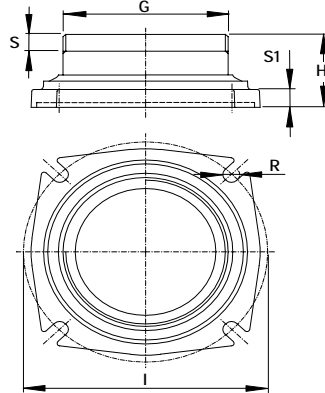
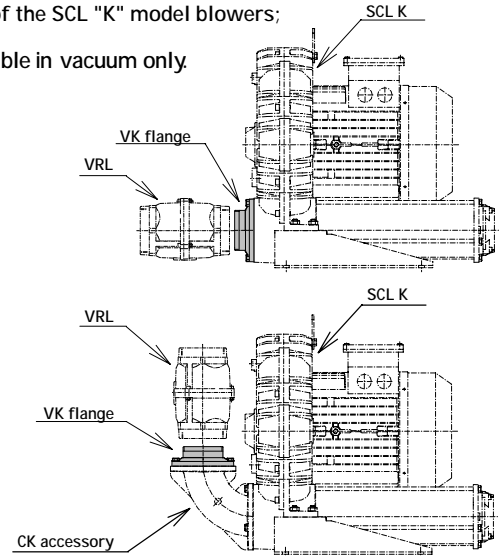

Fig. 2



Dimensions in Inches

Model	DN	G	H	I	R	S	S1	Fig.	Parts List
VK 5	1" 1/2	1" 1/2 NPT	1.18	3.62	0.26	0.59	0.39	1	SP 1552
VK 6	2"	2" NPT	1.97	4.33	0.33	0.75	0.39		SP 1553
VK 6A	2"	2" NPT	2.34	5.12	0.35	0.75	0.43	2	SP 1611
VK 8	3"	3" NPT	1.69	5.12	0.35	0.83	0.43		SP 1554
VK 9	4"	4" NPT	1.81	5.90	0.35	0.90	0.43		SP 1555

## PK - FLANGED TUBE CONNECTOR FOR SCL K

The PK accessory allows connection of the "K" Series blowers directly to the process line without use of the intake or outlet manifolds.

### CHARACTERISTICS

Flange in aluminium alloy with tube stub connection.

Supplied as a kit for mounting (with gasket and screws with wrench), please see the respective Parts List in table.

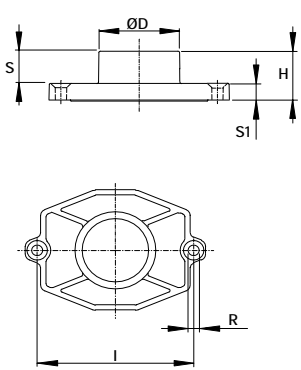

Fig. 1

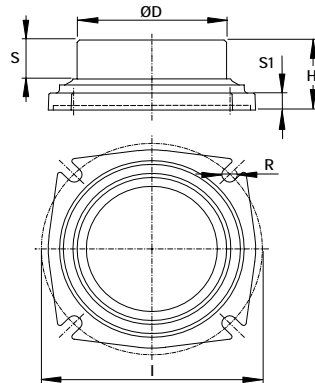

Fig. 1

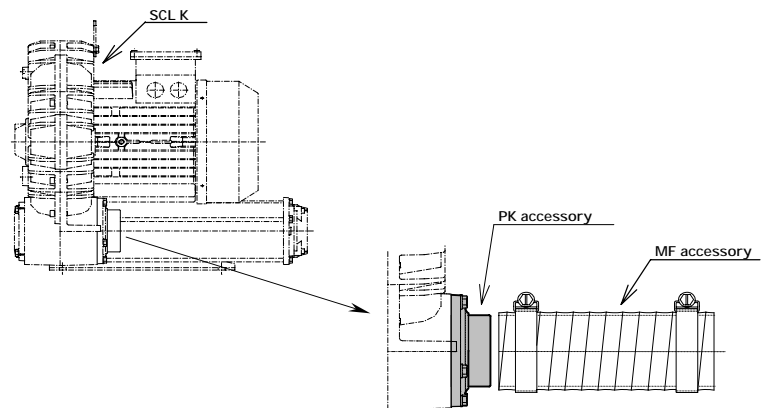

Fig. 2

Dimensions in Inches

Model	DN	D	H	I	R	S	S1	Fig.	Parts List
PK 5	1" 1/2	1.89	1.18	3.62	0.26	0.79	0.39	1	SP 1543
PK 6	2"	2.36	1.97	4.33	0.33	1.38	0.39		SP 1544
PK 6A	2"	2.36	2.34	5.12	0.35	1.38	0.43	2	SP 1609
PK 8	3"	3.46	1.69	5.12	0.35	0.94	0.43		SP 1545
PK 9	4"	4.48	1.81	5.90	0.35	1.06	0.43		SP 1546

Note: PK flanges usable on K-MS, K-TS, K-TD blowers in vacuum or pressure K-MD useable in vacuum only.



This all aluminum device is simple in both design and operation. Change of flow direction is attained by an electronically or pneumatically activated diverter.

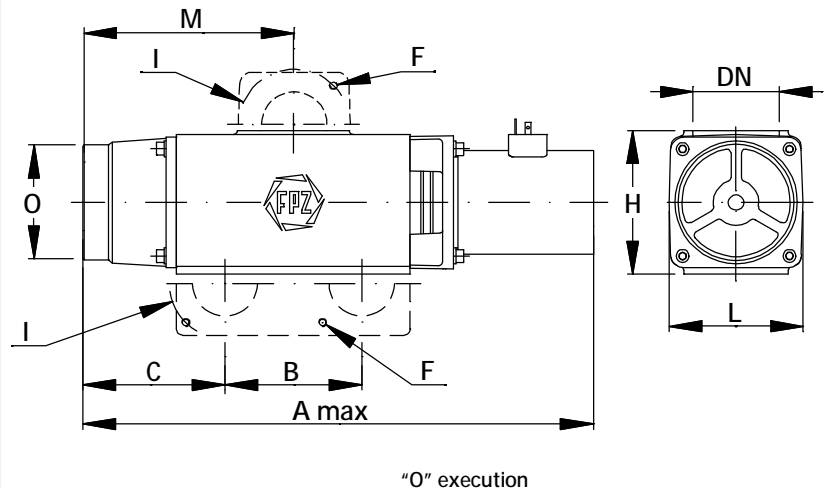
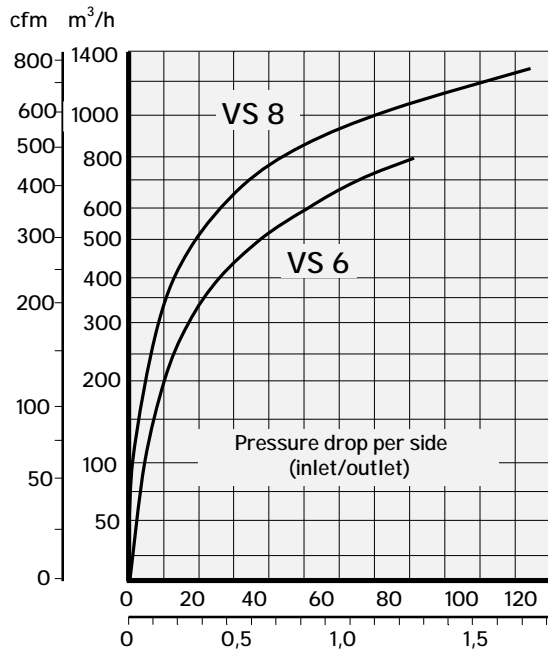

TYPE	DN	A		B	C	F	H	I	L	M	O
VS 6	2"	15.43 <sup>(1)</sup>	16.42 <sup>(2)</sup>	4.13	4.29	M6	4.33	2 x int.3.35	3.94	6.38	3.46
VS 8	3"	19.09 <sup>(1)</sup>	20.08 <sup>(2)</sup>	4.02	5.28	M6	6.3	4 x int.4.72	5.91	8.27	4.33

Overall dimensions refer to "O" execution without flanges

For the dimensions of the other executions pls see:

- SI 1787 Executions O/P
- SI 1788 Executions Y/H/K with pneumatic control
- SI 2021 Executions Y/H/K with electrical control

- (2) Electronically activated
- (3) Pneumatically activated

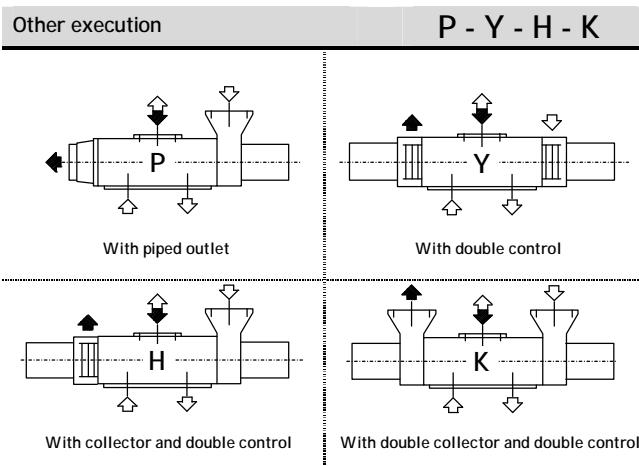

	EXECUTION	
	O/P	Y/H/K
<b>Electrical control</b>		
Thrust solenoid		
Working ratio	60% of cycle time	
Max. cycle duration	5 min.	
Max. activated time	5 min.	
Power rating	56 W	120 W (3)
Standard supply voltages	V: 24 DC-110 AC-220 AC	
(3) Only for VS6 (dp max. +350-350 mbar)		
<b>Pneumatic control</b>		
Thrust air cylinder	Double effect	
Max pressure	10 Bar	
Air consumption	0.02 litres/cycle	
Operating temperature	-5°C - +70 °C	

**Available connection**

- TF threaded flange GAS (G 1 1/2", G 2", G 3");
- TF threaded flange NPT (NPT 1 1/2", NPT 2", NPT 3");
- See SU 0012.

Dimensions in inches. Tolerance on given values ±10 % - unbinding and can be changed without prior notice.



**CA MANIFOLD FOR FA/FL/FS FILTERS**

90° wide radius PVC manifold with flanged connection and unthreaded or female threaded tube end. Working temperature -20° to +40°C (-5°/+105 °F).

Type	DN	A	B	D	S	I	M	R	Fig.
CA4-K	1.25"	10.24	6.30	1.65	0.59	2.52	0.28	3.15	1
CA4K-NPT	1.25" npt	11.61	6.30	1.65	0.59	2.52	0.28	3.15	1
CA5-K	1.5"	11.81	7.09	1.89	0.59	2.95	0.28	3.94	1
CA5K-NPT	1.5" npt	12.80	7.09	1.89	0.59	2.95	0.28	3.94	1
CA6V	2"	12.60	5.31	2.36	0.59	3.35	0.28	4.96	1
CA6V-NPT	2" npt	13.60	5.31	2.36	0.59	3.35	0.28	4.96	1
CA8	3"	14.96	7.28	3.48	0.59	4.72	0.28	7.09	1
CA8-NPT	3" npt	16.65	7.28	3.48	0.59	4.72	0.28	7.09	1
CA9	4"	15.75	9.25	4.48	0.79	5.91	0.35	8.66	2
CA9-NPT	4" npt	17.44	9.25	4.48	0.79	5.91	0.35	8.66	
CA10	5"	4.92	11.81	5.51	0.79	8.27	0.71	11.02	

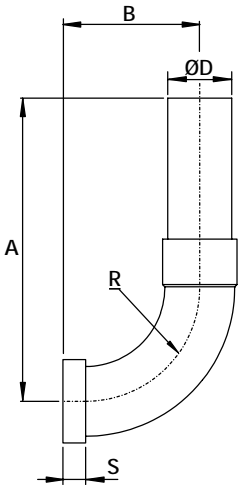

Dimensions in inches - unbinding and can be changed without prior notice.

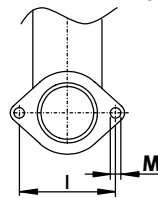

Fig. 1

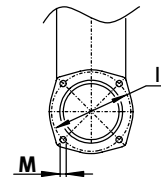

Fig. 2

**CK MANIFOLD**

90° aluminium manifold for "K" models supplied in a kit containing the gasket and bolts.

Fig. 1

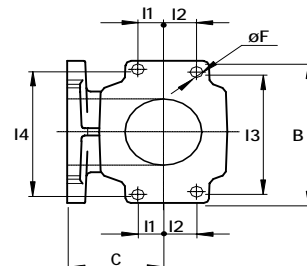
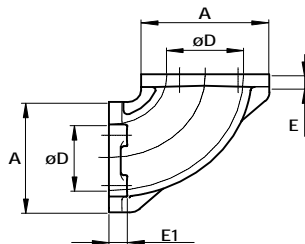
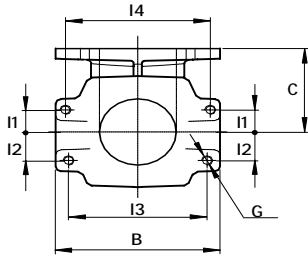
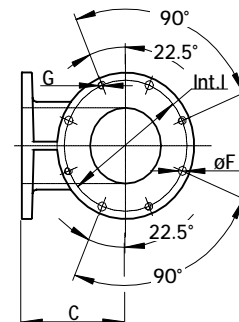
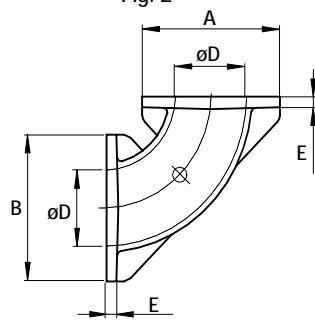
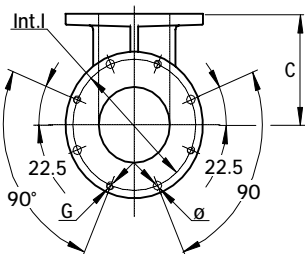

Fig. 2



Type	DN	A	B	C	D	E	E1	F	G	I	I1	I2	I3	I4	Fig.
CK5	1.5"	3.15	3.94	2.20	1.69	0.27	0.45	0.27	M6	-	0.69	0.69	3.35	3.35	1
CK6	2"	3.62	4.65	2.72	2.16	0.31	0.51	0.35	M8	-	0.73	0.95	3.92	4.10	
CK8	3"	5.71	5.71	4.31	2.95	0.39	-	0.35	M8	5.12	-	-	-	-	2
CK9	4"	6.50	6.50	5.22	3.54	0.39	-	0.35	M8	5.90	-	-	-	-	
CK10	5"	8.66	8.66	7.56	5.04	0.39	-	0.35	M8	7.48	-	-	-	-	

Dimensions in inches - unbinding and can be changed without prior notice.



### FLEXIBLE CONNECTION

Steel reinforced rubber - coated fibreglass flex tubing, including 2 adjustable hose clamps. Working temperature:  $-55 \div +176$  °C ( $-67 \div +350$  °F). Maximum working pressure: 3 bar (44 psi).

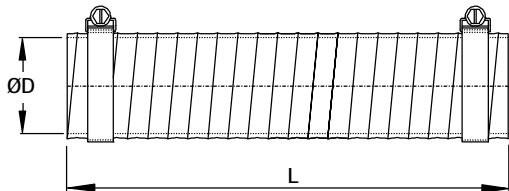

TYPE	DN	D	L
MF 1	1/2"	20	200
MF 2	3/4"	26	200
MF 3	1"	32	200
MF 4	1" 1/4	45	200
MF 5	1" 1/2	50	250
MF 6	2"	64	250
MF 8	3"	89	330
MF 9	4"	114	330
MF 10	5"	140	330

### THREADED FLANGE

Threaded flange in aluminum alloy.

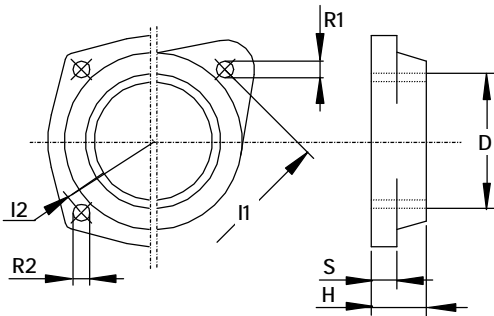

TYPE	D	H	I1	I2	R1	R2	S
TF 4N	1" 1/4 npt	18	75	-	6.5	-	10
TF 4VN	1" 1/4 npt	18	64	-	6.5	-	10
TF 5N	1" 1/2 npt	18	85	-	6.5	-	10
TF 5VN	1" 1/2 npt	18	75	-	6.5	-	10
TF 6N	2" npt	18	85	-	6.5	-	10
TF 8N	3" npt	25	-	120	-	6.5	13
TF 9N	4" npt	25	-	150	-	9	13
TF 10N	5" npt	35	-	210	-	17	13

### SLEEVE

Aluminum alloy or steel flanged sleeve coupling.

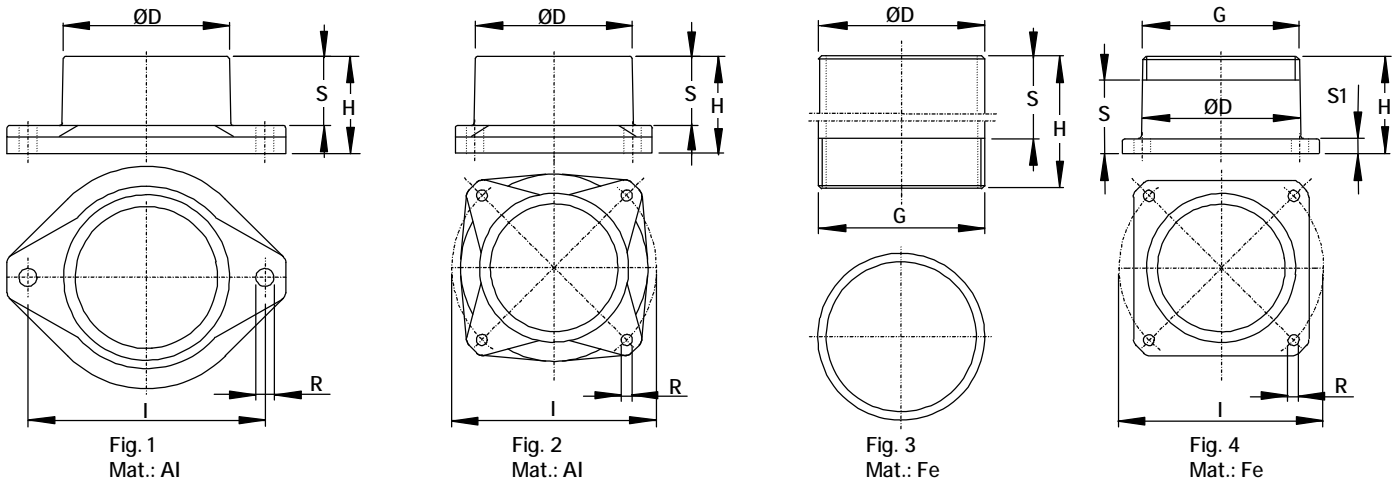

TYPE	DN	D	G	H	I	R	S	Fig.
MP 3	1"	33	-	35	55	6.5	25	1
MP 4	1" 1/4	42	-	35	75	6.5	25	
MP 4V	1" 1/4	42	-	35	64	6.5	25	

TYPE	DN	D	G	H	I	R	S	S1	Fig.
MP 5V	1" 1/2	48	-	35	75	6.5	25	-	1
MP 6	2"	60	-	35	85	6.5	25	-	
MP 8	3"	88	-	45	120	6.5	32	-	2
MP 9	4"	114	4" npt	100	-	-	80	-	3
MP 10	5"	140	5" npt	60	210	18	40	8	4

Dimensions in mm. Tolerance on given values  $\pm 10\%$  - unbinding and can be changed without prior notice.

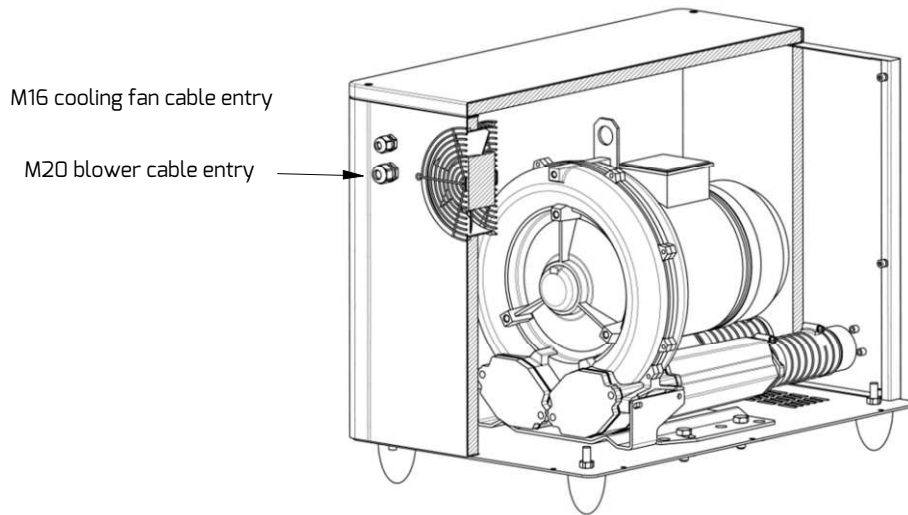

### Scl performances inside the sound hood IH1-IH5

SCL	Sound hood	Installed motor power	Differential pressure
K03-MS	IH1	0.5 hp	See data sheet
		0.75 hp	See data sheet
K04-MS	IH3	1 hp	See data sheet
		1.5 hp	See data sheet
		2 hp	See data sheet
R20-MD	IH4	1.5 hp	See data sheet
R30-MD	IH4	2 hp	See data sheet
		3 hp	See data sheet
R40-MD	IH4	3 hp	See data sheet
		4 hp	See data sheet
K05-MS	IH5	1.5 hp	See data sheet
		2.0 hp	See data sheet
		3.0 hp	See data sheet
		4.0 hp	See data sheet
K06-MS	IH5	3.0 hp	See data sheet
		4.0 hp	See data sheet
		5.5 hp	100 in WG/7.4 in Hg max

If using a CA 90 degree manifold for filter installation, a spacer is required when using 2" npt filters. Applicable with IH5 sound enclosures.

### Sound hood characteristics IH1-IH5

- Noise reduction 10 dB(A) max
- Sheet metal, painted (RAL 9001), internally-lined with sound-absorbing foam panels
- Integral exhaust fan for blower / motor heat dispersion
- Bottom plate slotted for ventilation
- Hood raised and supported using 4 external anti-vibration mounts
- Blower internal mounting kit supplied
- Ability to mount blower accessories directly on the hood
- Models IH1-IH5 are supplied with flanges, bolts and flexible connections for easy blower installation.

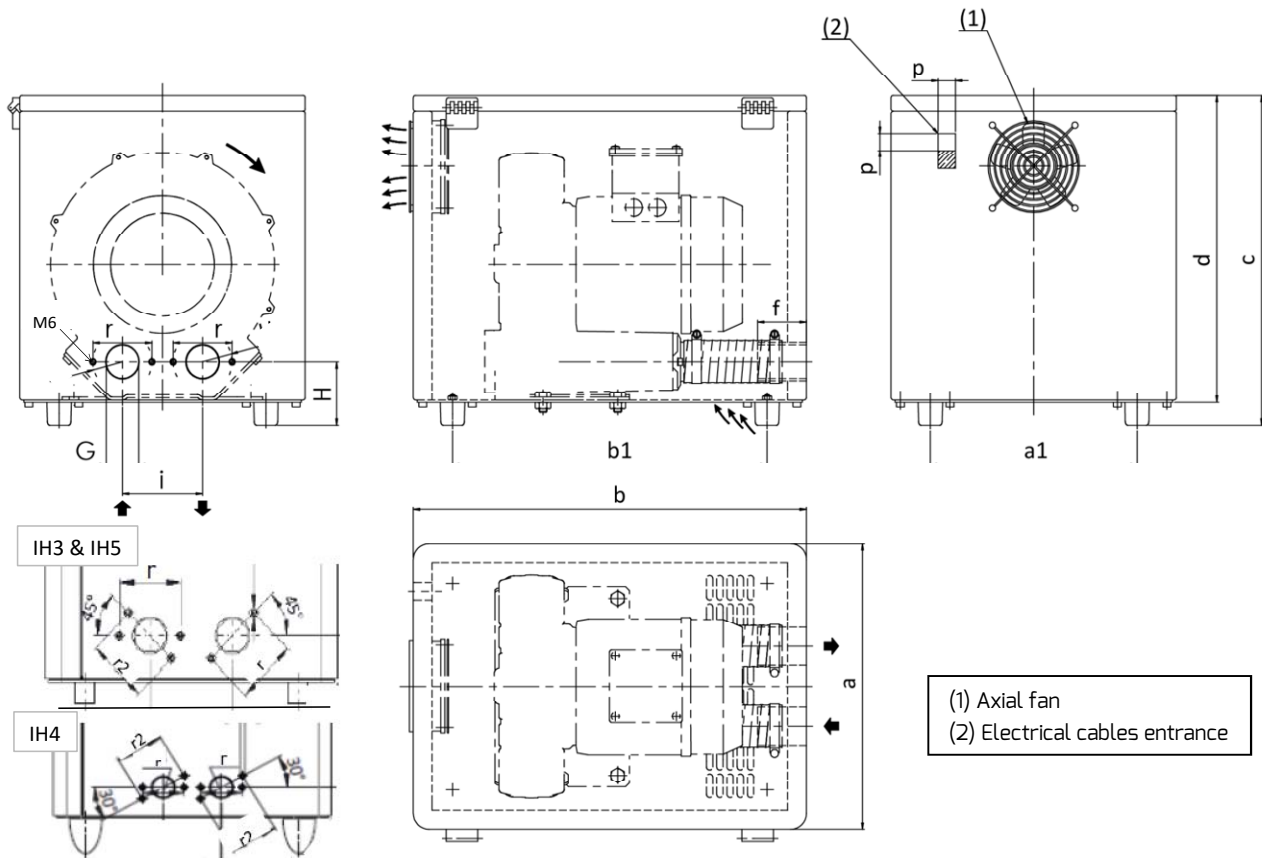

Dimensions in inches - FOR REFERENCE ONLY

Model	Blower(s)	a	a1	b	b1	c	d	f	G	H	i	q	r	r2	lbs
IH1	K03-M5	13.38	9.45	18.19	14.25	15.8	14.68	2.2	1.4	2.97	3.38	-	2.52	-	37.5
IH3	K04-M5	14.3	10.4	19.7	15.8	16.5	15.4	2.4	1.6	2.1	4.0	0.9	2.95	2.95	37.9
IH4	R20-MD, R30-MD, R40-MD	16.9	12.6	26.8	22.4	21.6	18.9	2.2	1.4	4.7	3.5	1.5	2.52	2.95	61.1
IH5	K05-M5, K06-M5	16.9	12.6	26.8	22.4	21.6	18.9	3.0	2.1	4.7	4.4	2.4	3.35	3.35	61.7

### FAN CHARACTERISTICS (SINGLE PHASE)

	IH1 - IH3		IH4 - IH5	
Frequency [Hz]	50	60	50	60
Power [W ±10%]	18	15	46	44
Power supply [V]	220-240		230±10%	
Nom. absorption [A ±10%]	0.13	0.09	0.30	0.28
Protection	IP 44		IP 54	
Phases	1			
Poles	2			
Operating temperature	-20°C to +70°C			

115 VAC - 60 hz - single phase fan options are available upon request



**CHARACTERISTICS:**

- Suitable for MOR blowers only.
- Suitable for outdoor installations.
- Noise reduction **10 dB(A)** max.
- With electric axial fan (1) removing heat, generated by the motor and blower (2).
- With air inlet grille for ventilation.(3).
- Steel sheet structure (4).
- Folding roof opening (90°), for blower installation/inspection (5).
- Internal coated with polyurethane foam (sound-absorbing material) (6).
- Complete with accessories for blower connection (7), assembly with 4 shock mounts washer
- Cabinet with feet.
- Palletizable.
- Stackable cabinet (max 2 pieces) (8).
- Paint RAL 9001.
- On request, available in assembly kit.

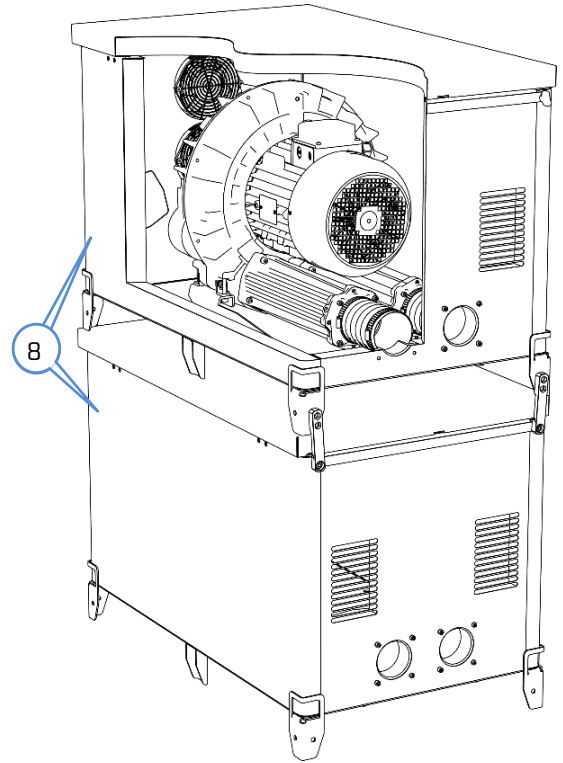
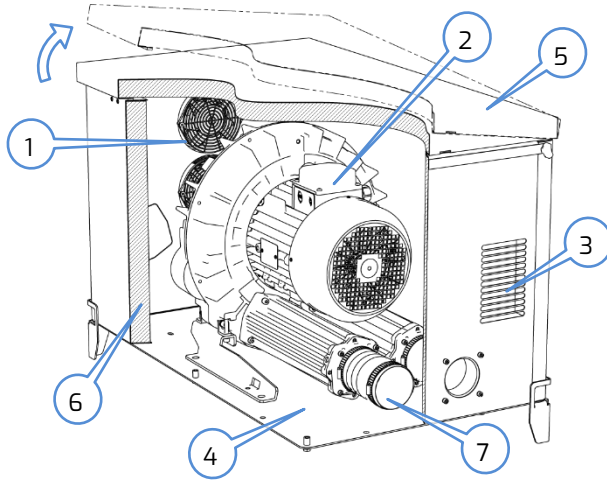

CODE	WEIGHT*	MOR BLOWER COMPATIBLE				AXIAL ELECTRIC FAN (1)							
	kg	MS	MD	TS	TD	q.tà	Hz	V	W	mA	Phase	Pole	IP
25SC 6 M - 2	40		K/e07 K/e08			2	50	230	46	300	1	2	54
25SC 6 M - 3	40				K05 K06		60		44	280			
25SC 8 M - 1	51	K/e07 K/e08	K75		K05 K06								
25SC 8 M - 2	52				K/e07 K/e08								

\*- Weight cabinet only

**DIMENSION (SC6M-1)**

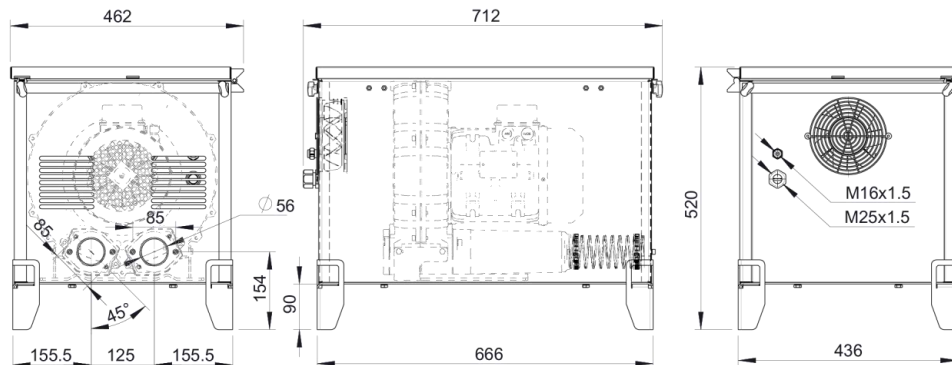





Sizes in (mm) NOT BINDING

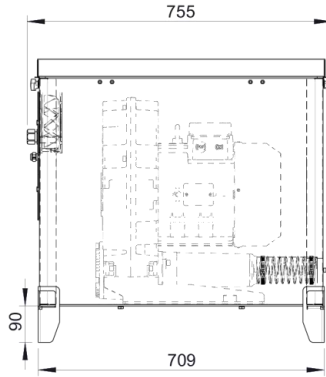
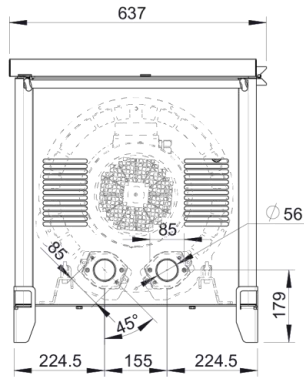

**DIMENSION (SC6M-2)**

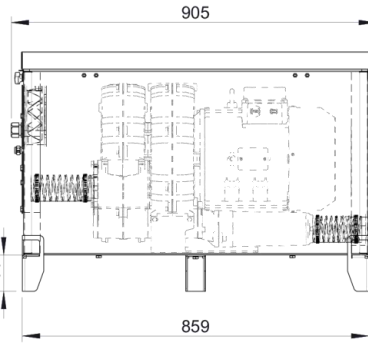
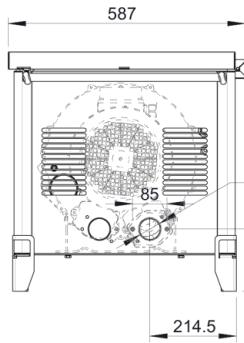
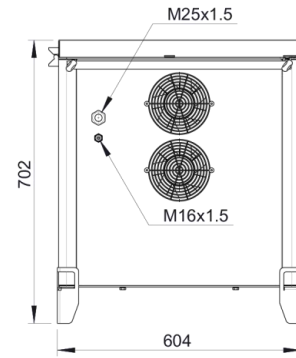

**DIMENSION (SC6M-3)**

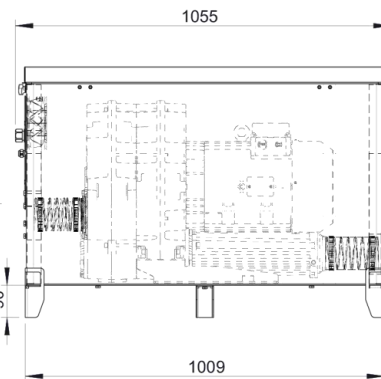
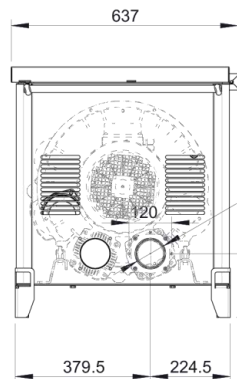
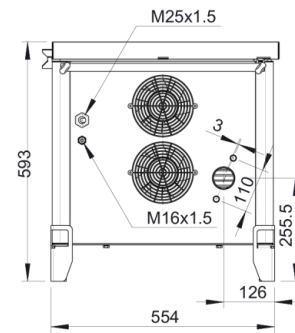

**DIMENSION (SC8M-2)**

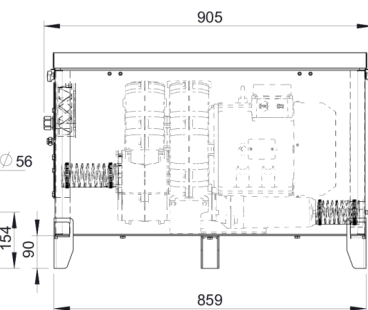
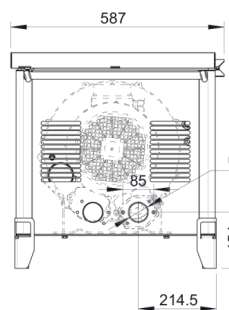
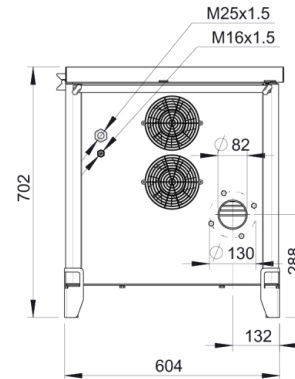

**DIMENSION (SC6M-3)**

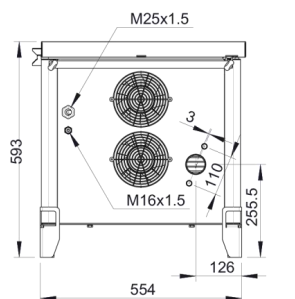

**CHARACTERISTICS:**

- Suitable for MOR blowers only.
- Suitable for outdoor installations.
- Noise reduction **10 dB(A)** max.
- With electric axial fan [1] removing heat, generated by the motor and blower[2].
- With air inlet grille for ventilation.[3].
- Aluminium profile frame [4].
- Sandwich panels insulated with mineral wool (sound absorbing / sound insulation) [5].
- Demountable panels with block-panel [6].
- Assembly from top (drop on the blower).
- Floor fixing points available (x2) [7].
- Polyester painted panels RAL 7035.

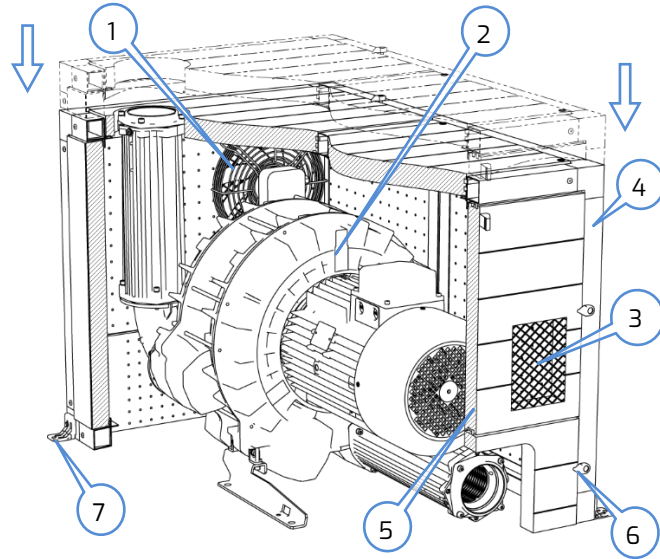

CODE	WEIGHT*	MOR BLOWER COMPATIBLE				AXIAL ELECTRIC FAN**[1]										
	kg	MS		MD		TS		TD	q.tà	Hz	V	W	A	Phase	Pole	IP
255C 9 M - 1	81	K09	K10	K09	K10	K/e07	K/e08		1	50 60	230	90 110	0.42 0.52	1	2	54
		K/e11	K/e12	K/e11	K/e12											
255C 9 M - 2	81							K09	K10							
								K/e11	K/e12							
255C 10 M	81					K09	K10									
						K/e11	K/e12									

\* - Cabinet weight only  
\*\* - Capacitor 3µF 450V

**NOTE**

- Stackable cabinets (255B accessory required) for max 2 units. Not applicable to cabinet code 255C9-2, only if used as a base (TD blower)
- Standard CA filter manifold cannot be used with 255C9M-1  
- for 255C9M-1 use CA9L

**DIMENSION (SC9M-1)**

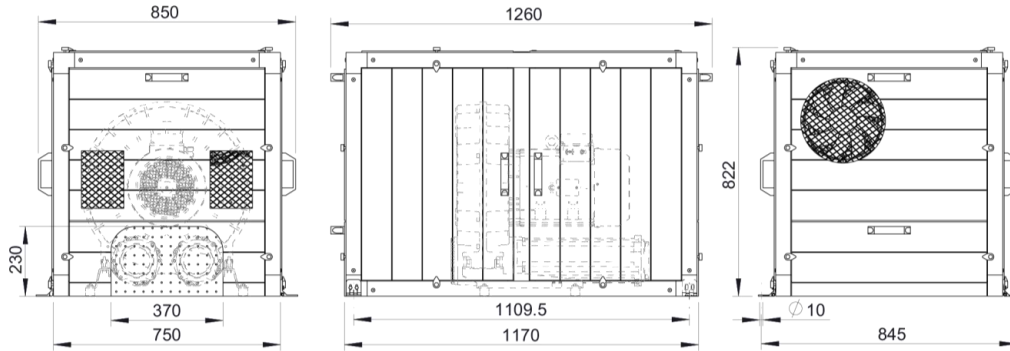

**DIMENSION (SC9M-2)**

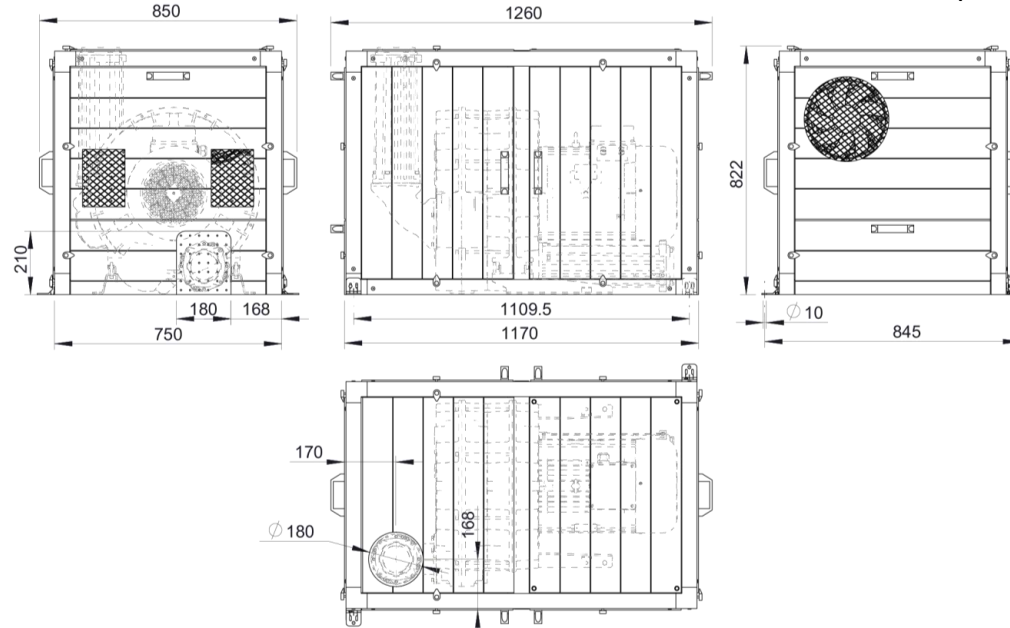

**DIMENSION (SC10M)**

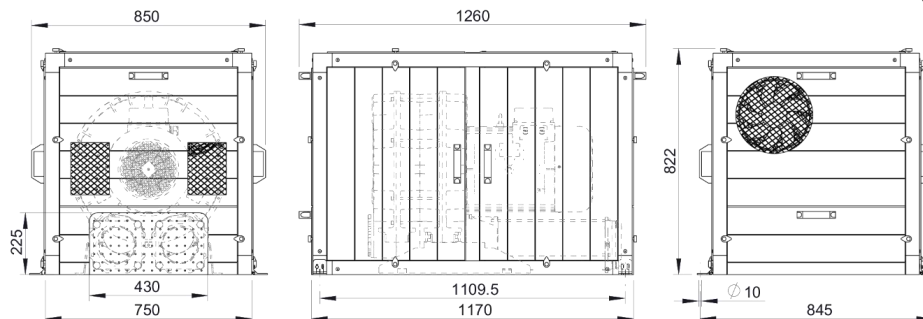

**CHARACTERISTICS:**

- Suitable for outdoor installations.
- Aluminium profile frame [1].
- Sandwich panels insulated with mineral wool (sound absorbing / sound insulation) [2].
- Omega for blower fixing [3] assembly with 4 shock mounts washer
- Fixing with blower by hinge [4]
- Makes the cabinet Palletizable
- Makes the cabinet stackable (max 2 pieces) [5]
- Polyester painted panels RAL 7035.

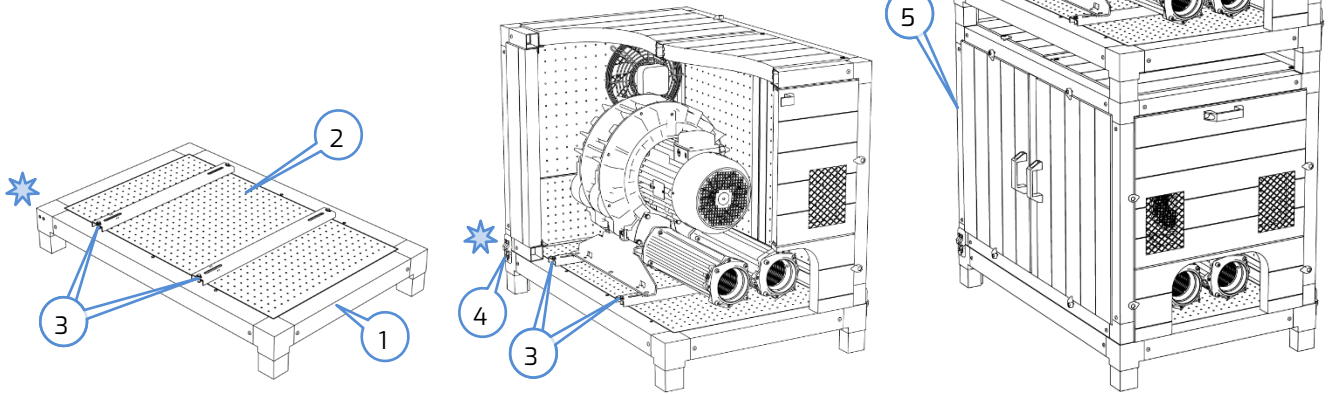

**DIMENSION (SB-1)**

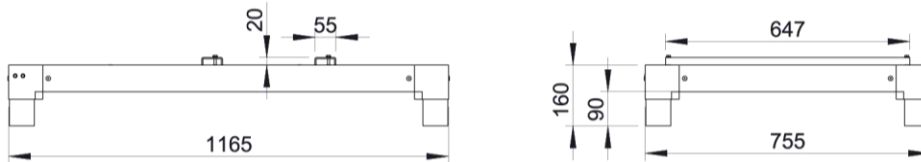

**OMEGA POSITION FOR BLOWER INSTALLATION [4]**

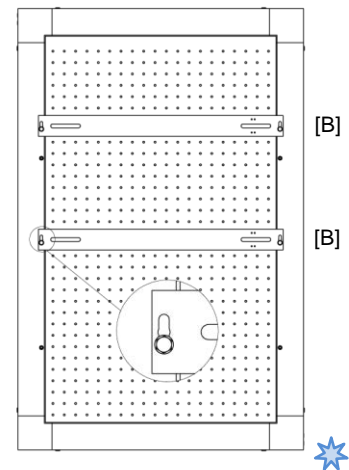
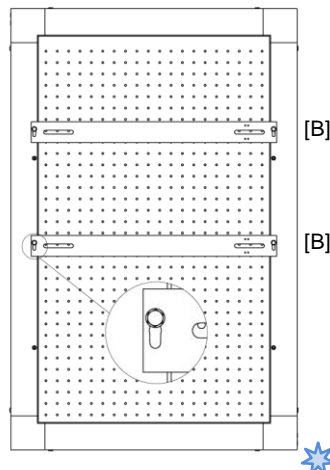
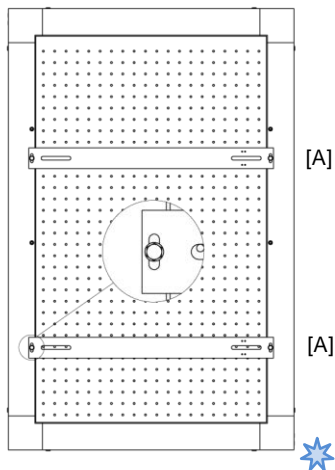

MS			K09	K10	K/e11	K/e12
MD			K09	K10	K/e11	K/e12
TS	K/e07	K/e08	K09	K10	K/e11	K/e12
TD			K09	K10	K/e11	K/e12



## Description and Features

- Direct On-Line Starters in polycarbonate enclosure Rated Nema 4
- All contactors and overload relays are UL approved
- AC 3 phase Inductive Motor rating from 9 amp through 80 amp
- Fully assembled single and three phase starters
- No cover wiring required
- "Start-Stop" or "Reset" external buttons come standard



## Technical specifications

### 3 Motor Starters

Model	HP	Voltage	HZ	Contactor size	Overload
AF0906P1G-3E	2	208V-230V	60	9A	5.7A - 7.6A
AF1206P1G-3F	3	208V-230V	60	12A	7.6A - 10A
AF2606P1M-3I	5.5	208V-230V	60	26A	16A - 20A
AF2606P1M-3J	7.5	208V-230V	60	26A	20A - 24A
AF3806P1M-3K	10	208V-230V	60	38A	24A - 29A
AF5206P1K-3Q	15	208V-230V	60	52A	36A - 47A
AF6506P1K-3R	20	208V-230V	60	65A	44A - 53A
AF8006P1K-3W	25	208V-230V	60	80A	57A - 68A
AF0906P1G-4F	5.5	460V	60	9A	7.6A - 10A
AF1606P1G-4G	7.5	460V	60	16A	10A - 13A
AF1606P1G-4H	10	460V	60	16A	10A - 16A
AF2606P1M-4I	15	460V	60	26A	16A - 20A
AF3806P1M-4K	20	460V	60	38A	24A - 29A
AF5206P1K-4P	25	460V	60	52A	30A - 40A

## Optional

- Different coil voltages are available for remote starting.
- 24 VDC or 115VAC coil voltages
- Configuration for remote start
- Terminal strip for thermal protector connection





TM

ACCESSORIES

# Control Panels and Variable Frequency Drives

## Control panels

FPZ CONTROL PANELS ARE A SIMPLE WAY TO SAFELY START AND CONTROL FPZ BLOWERS WITH EITHER A SINGLE PHASE OR THREE PHASE POWER SUPPLY.

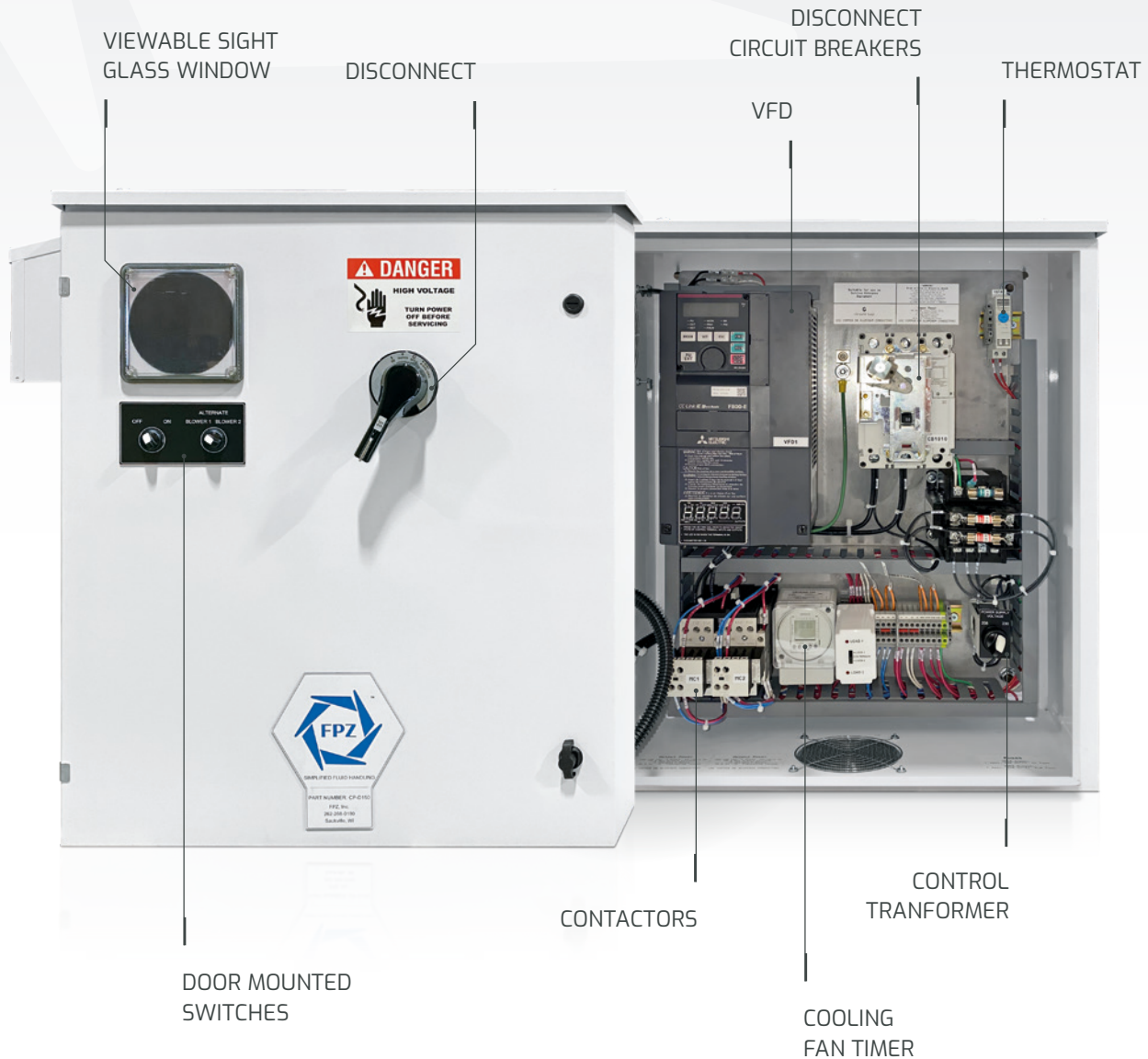





# Control Panels and Variable Frequency Drives

## Standard Features

- Nema 3R enclosure
- VFD mounted in panel with viewable sight glass window
- Single phase or three phase supply power options
- Adjustable internal timer for duplex panels
- Circuit breaker
- Control transformer
- Disconnect
- Cooling fans controlled by thermostat
- Door mounted switches
- VFD programmed by FPZ

## Technical specifications

### Duplex Control Panels - 230 V - 1 phase input power

Model	HP	Voltage	Max 3ø output amperage
CP-D0401230	4	230V	13.8
CP-D6201230	6.2	230V	18.6
CP-D1001230	10	230V	34.8
CP-D1501230	15	230V	42.3
CP-D2001230	20	230V	51.0

## Optional

- Simplex panel available
- Different voltages
- Custom programing
- Transducer integration
- Terminal inputs for SCADA or other external signal

### Variable Frequency Drive - 1 phase input power

Model	HP	Voltage	Max 3ø output amperage
CP-V0151230	1.0-1.5	208V-230V	5.76
CP-V0301230	2.0 - 3.0	208V-230V	9.12
CP-V0401230	4	208V-230V	13.8
CP-V0621230	5.5 - 6.2	208V-230V	18.6
CP-V1001230	10	208V-230V	34.8
CP-V1501230	15	208V-230V	42.3
CP-V2001230	20	208V-230V	51.0
CP-V2501230	25	208V-230V	68.4

### Variable Frequency Drive - 3 phase input power

Model	HP	Voltage	Max 3ø output amperage
CP-V0103230	1.0	208V-230V	4.2
CP-V0203230	1.5 - 2.0	208V-230V	4.35
CP-V0303230	3	208V-230V	9.6
CP-V0403230	4	208V-230V	15.2
CP-V0753230	5.5 - 7.5	208V-230V	23.0
CP-V1003230	10	208V-230V	31.0
CP-V1503230	15	208V-230V	45.0
CP-V2003230	20	208V-230V	58.0
CP-V2503230	25	208V-230V	70.5
CP-V3003230	30	208V-230V	85.0

### Variable Frequency Drive - 3 phase input power

Model	HP	Voltage	Max 3ø output amperage
CP-V0103460	1.0	460V	2.1
CP-V0153460	1.5	460V	2.88
CP-V030460	2.0 - 3.0	460V	4.56
CP-V0403460	4.0	460V	6.9
CP-V0623460	5.5 - 6.2	460V	8.2
CP-V1003460	7.5 - 10	460V	13.8
CP-V1503460	15	460V	21.0
CP-V2003460	20	460V	25.8
CP-V2503460	25	460V	34.2

Models that start with "CP-V" are for VFD's ONLY as pictured





## SINGLE PHASE DUAL VOLTAGE

### GENERAL SPECIFICATIONS:

- |  |  |
|--|--|
| <ol style="list-style-type: none"> <li>1. Type: AC Motor IEC 60034</li> <li>2. Marks: cURus, CE</li> <li>3. Poles: 2</li> <li>4. Insulation class: F</li> <li>5. Frequency: 60 hz</li> <li>6. Enclosure: TEFC</li> </ol> | <ol style="list-style-type: none"> <li>7. Protection IP55, Tropicalized</li> <li>8. Thermal protector: Klixon 140<sup>o</sup> C or 150<sup>o</sup> C (R series)</li> <li>9. Max. Ambient 40<sup>o</sup> C</li> <li>10. Duty: Continuous</li> <li>11. Construction: aluminum frame</li> </ol> |
|--|--|

POWER		SIZE	VOLTAGE (60 hz)	Full Load Amperage	Starting Current A	Power Factor	SF	Capacitor µF	Cable Entry
HP	KW								
0.33	0.25	63	115 / 208-230	3.5 / 1.7	12.3 / 6.0	0.97	1.0	16 - 400 V	M16
0.5	0.37	63	115 / 208-230	4.8 / 2.6	20 / 10.1	0.96	1.0	16 - 400 V	M16
0.75	0.55	71	115 / 208-230	8.3 / 4.1-4.2	34.9 / 17.2	0.83	1.15	30 - 450 V	M20
1	0.75	80	115 / 208-230	9.4 / 5.5-5.0	35.8 / 17.3	0.99	1.15	40 - 450 V	M20
1.5	1.1	80	115 / 208-230	13.89 / 7.6-7.3	49.3 / 23.2	0.97	1.15	45 - 450 V	M20
1.5*	1.1	80	115 / 208-230	14.3 / 7.18	71.1 / 35	0.96	1.0	55 - 450 V	M20
2	1.5	90	115 / 208-230	19.7 / 10.6-9.9	103 / 52.4	0.95	1.15	50 - 450 V	M20
2*	1.5	80	115 / 208-230	19.4 / 9.8	96 / 48.2	0.89	1.0	55 - 450 V	M20
3	2.2	90	115 / 208-230	29.4 / 16.6-14.8	119.8 / 61.8	0.91	1.15	60 - 450 V	M20
3*	2.2	90	115 / 208-230	26.2 / 13.1	152 / 76	0.95	1.0	70 - 450 V	M20

\* Applicable to R series ONLY.

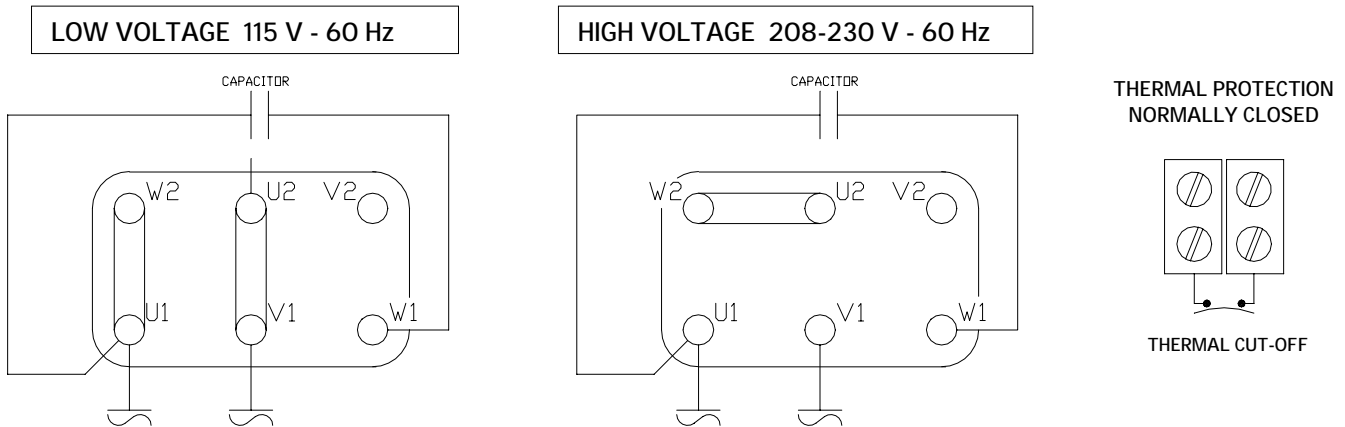

Specifications subject to change without notice. Alternate motor suppliers may be used.





THREE PHASE MOTOR

GENERAL SPECIFICATIONS:

1. Type: 3-phase AC Motor IEC 60034
2. Marks: cURus, CE
3. Nema Premium Efficiency (IE3) - 1 HP AND LARGER (3 ph)
4. Poles: 2
5. Insulation class: F; F (B) for Premium efficient
6. Enclosure: TEFC
7. Protection IP55, Tropicalized
8. Thermal protector: Klixon 140°C/150°C
9. Service factor: 1.15 (60 hz)
10. Max. Ambient 40° C
11. Duty: Continuous
12. Construction: aluminum frame

POWER		SIZE	60 HZ			50 HZ			60 hz Starting Current Ratio*	CABLE ENTRY 1 (cable gland incl.)	CABLE ENTRY 2
HP	KW		VOLTAGE	FLA 208-230 / 460 V	Efficiency	VOLTAGE	FLA 200/400 V	Efficiency			
0.33	0.25	63	208-230/460	1.5 / 0.7	59%	230/400	1.4 / 0.8	60.0%	3.9	M16	M20
0.5	0.37	63	208-230/460	2.3 / 1.0	59.2%	230/400	2.1 / 1.2	61.4%	3.6	M16	M20
0.75	0.55	71	208-230/460	2.7 / 1.2	68.8%	230/400	2.6 / 1.5	69.0%	3.8	M16	M20
0.75	0.55	71	208-230/460	2.3-2.2 / 1.3	74.5%	230/400	2.6 / 1.5	74.5%	6.8	M20	-
1	0.75	80	208-230/460	2.99-2.94 / 1.47	77.0%	200/400	3.28 / 1.64	80.7%	8.0	M25	M25
1.5	1.1	80	208-230/460	4.35-4.34 / 2.17	84.0%	200/400	4.92 / 2.46	82.8%	9.3	M25	M25
2	1.5	80**	208-230/460	5.91-5.96 / 2.98	85.5%	200/400	6.82 / 3.41	84.2%	8.7	M25	M25
		90	208-230/460	5.77-5.74 / 2.87	85.5%	200/400	6.58 / 3.29	84.2%	9.4	M25	M25
3	2.2	90	208-230/460	8.27-8.31 / 4.15	86.5%	200/400	9.6 / 4.8	85.9%	10.7	M25	M25
4	3	100	208-230/460	10.9-11.1 / 5.53	88.5%	200/400	12.86 / 6.38	87.1%	11.0	M25	M25
5.5	4	100	208-230/460	14.6-15.1 / 7.55	88.5%	200/400	17.7 / 8.86	88.1%	11.1	M25	M25
6.2	4.6	100	208-230/460	16.5-16.4 / 8.2	89.5%	200/400	19 / 9.5	88.6%	12.5	M25	M25
7.5	5.5	132	208-230/460	19.8-19.5 / 9.75	89.5%	200/400	22.2 / 11.1	89.2%	13.7	M25	M25
10	7.5	132	208-230/460	26.1-25 / 12.5	90.2%	200/400	28.6 / 14.3	90.1%	13.0	M25	M25
15	11	132	208-230/460	38.2-37.3 / 18.7	91.0%	200/400	43.4 / 21.7	91.0%	12.5	M25	M25
20	15	132	208-230/460	47.0 / 23.5	91.7%	200/400	52.4 / 26.2	91.9%	9.7	M32	M32
20***	15	160	208-230/460	48.8 / 24.4	91.0%	200/400	54.4 / 27.2	91.9%	10.7	M32	M32
25	18.5	160	208-230/460	62 / 31	91.7%	200/400	69 / 34.5	92.4%	12.5	M40	M40
30	22	160	208-230/460	71.6/35.8	91.7%	200/400	77.8 / 38.9	92.7%	10.6	M40	M40

\* FLA x starting current ratio = starting current \*\* 2 hp size 80 motors used on SCL R30-MD ONLY. \*\*\* T5 / TD models ONLY.

Shaded models to be discontinued

WIRING DIAGRAMS

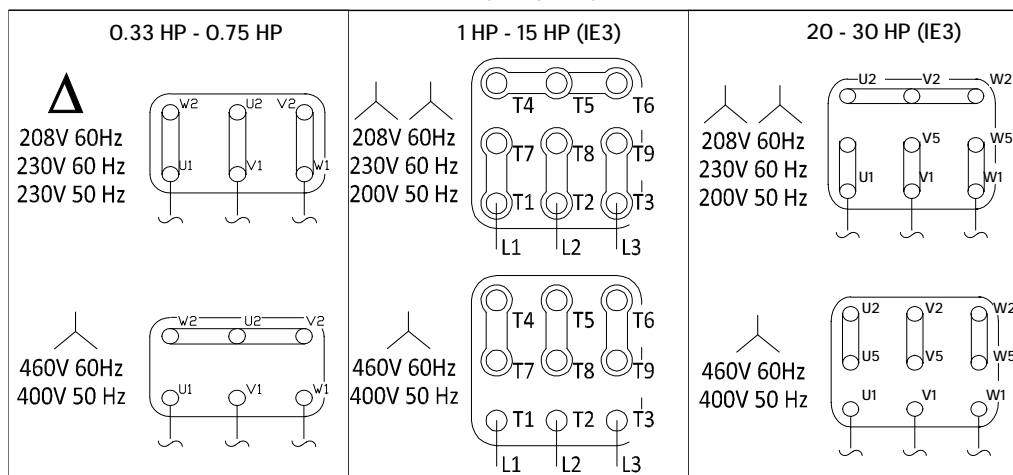

Thermal protection

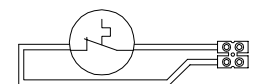

$V_N = 250V, \cos\phi 0,6, I_N = 1,6 A$   
 $V_N = 250V, \cos\phi 1, I_N = 2,5 A$

Specifications subject to change without notice. Alternate motor suppliers may be used.



# 575 Volt Three Phase Electric Motors

TECHNICAL

SS2101

## 575 V THREE PHASE MOTOR

### GENERAL SPECIFICATIONS:

1. Type: 3-phase AC Motor IEC 60034
2. Marks: cURus, CE, Nema Premium Efficiency (IE3)
3. Poles: 2
4. Insulation class: F (B)
5. Frequency: 60 hz / 50 hz
6. Enclosure: TEFC
7. Protection IP55, Tropicalized
8. Thermal protector: Klixon 150<sup>0</sup> C
9. Service factor: 1.15 (60 hz)
10. Max. Ambient 40<sup>0</sup> C
11. Duty: Continuous
12. Construction: aluminum frame

POWER		SIZE	60 HZ			Starting Current A	Cable Entry
HP	KW		VOLTAGE	FLA 575 V	Efficiency		
1	0.75	80	575	1.18	77.0%	9.5	M25
1.5	1.1	80	575	1.74	84.0%	16.2	M25
2	1.5	80*	575	2.14	85.5%	17.0	M25
		90	575	2.3	85.5%	21.7	M25
3	2.2	90	575	3.0	86.5%	29.1	M25
4	3	100	575	3.94	88.5%	39.8	M25
5.5	4	100	575	5.31	88.5%	57.9	M25
6.2	4.6	100	575	6.0	89.5%	-	M25
7.5	5.5	132	575	7.21	89.5%	97.4	M25
10	7.5	132	575	10	90.2%	129.0	M25
15	11	132	575	13.9	91.0%	152.9	M25
20	15	132	575	18.8	91.0%	184.3	M25
25	18.5	160	575	24.8	91.7%	310.0	M40
30	22.0	160	575	28.6	91.7%	303.2	M40

\* 2 hp size 80 motors used on SCL R30-MD ONLY.

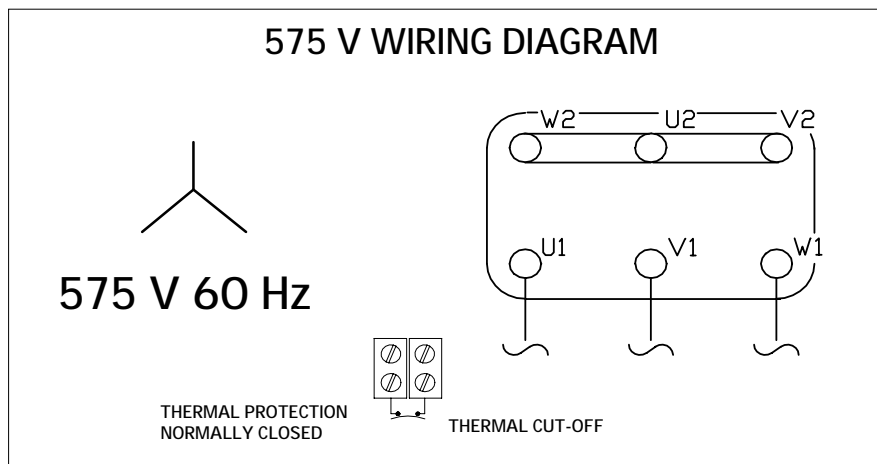

Specifications subject to change without notice. Alternate motor suppliers may be used.



PSI	In. H2O	In. Hg	mBar	mmH2O
1	27.68	2.04	68.95	703.0
1.5	41.5	3.05	103.43	1054.5
2	55.4	4.07	137.90	1406.0
2.5	69.2	5.09	172.38	1757.5
3	83.0	6.11	206.85	2109.0
3.5	96.9	7.13	241.33	2460.5
4	110.7	8.14	275.80	2812.0
4.5	124.6	9.16	310.28	3163.5
5	138.4	10.18	344.75	3515.0
5.5	152.2	11.20	379.23	3866.5
6	166.1	12.22	413.70	4218.0
6.5	179.9	13.23	448.18	4569.5
7	193.8	14.25	482.65	4921.0
7.5	207.6	15.27	517.13	5272.5
8	221.4	16.29	551.60	5624.0
8.5	235.3	17.31	586.08	5975.5
9	249.1	18.32	620.55	6327.0
9.5	263.0	19.34	655.03	6678.5
10	276.8	20.36	689.50	7030.0

Pressure			
In. H <sub>2</sub> O	x	0.03613	= psi
In. H <sub>2</sub> O	x	0.07355	= In. Hg
mbar	x	0.4019	= In. H <sub>2</sub> O
psi	x	2.036	= In. Hg

Flow			
m <sup>3</sup> /h	x	0.588	= cfm
lpm	x	0.03528	= cfm
cfm	x	1.699	= m <sup>3</sup> /h
cfm	x	28.32	= lpm

Length			
Feet	x	12	= Inches
Inches	x	2.54	= cm
Feet	x	0.3048	= meters

**Barometric pressure varies in direct proportion to altitude**

Example #1 – If a blower is required to deliver 2 psig at 5000 feet, what pressure at standard air is required?

$$\text{Pressure} = 14.7 / 12.23 \times 2 = 2.4 \text{ psig}$$

Example #2– If a blower is required to deliver 2 psig at standard air, what pressure will it deliver at 5000 feet?

$$\text{Pressure} = 12.23 / 14.7 \times 2 = 1.66 \text{ psig}$$

**Altitude Versus Barometric Pressure**

Altitude Feet	Pressure		Altitude Feet	Pressure		Altitude Feet	Pressure	
	In. Hg.	Psia		In. Hg.	Psia		In. Hg.	Psia
0	29.92	14.70	1500	28.33	13.90	7000	23.09	11.34
500	29.38	14.43	2000	27.82	13.67	7500	22.65	11.12
600	29.28	14.38	2500	27.31	13.41	8000	22.22	10.90
700	29.18	14.33	3000	26.81	13.19	8500	21.80	10.70
800	29.07	14.28	3500	26.32	12.92	9000	21.38	10.50
900	28.97	14.23	4000	25.84	12.70	9500	20.98	10.90
1000	28.86	14.18	4500	25.36	12.45	10000	20.58	10.10
1100	28.75	14.09	5000	24.89	12.23	10500	20.18	9.91
1200	28.65	14.04	5500	24.43	12.00	11000	19.79	9.72
1300	28.54	13.99	6000	23.98	11.77	11500	19.41	9.53
1400	28.44	13.94	6500	23.53	11.56	12000	19.03	9.35



# Airflow Through an Orifice

## Pressure

Orifice Diameters - Inches

Pressure " H <sub>2</sub> O	1/32	1/16	1/8	3/16	1/4	5/16	3/8	7/16	1/2	5/8	3/4	1	1-1/4	1-1/2	1-3/4	2.0	2-1/4	2-1/2	2-3/4	3
1	0.0	0.1	0.2	0.5	0.9	1.4	2.0	2.7	3.5	6	7.8	14	22	31	43	56	70	87	105	125
2	0.0	0.1	0.3	0.7	1.2	1.9	2.8	3.8	4.9	8	11	20	31	44	60	79	100	123	149	177
3	0.0	0.1	0.4	0.8	1.5	2.4	3.4	4.6	6.0	10	14	24	38	54	74	96	122	150	182	217
4	0.0	0.1	0.4	1.0	1.7	2.7	3.9	5.3	7.0	11	16	28	43	63	85	111	141	174	210	250
5	0.0	0.1	0.5	1.1	1.9	3.0	4.4	6.0	7.8	12	18	31	49	70	95	124	157	194	235	280
10	0.0	0.2	0.7	1.5	2.8	4.3	6.2	8.4	11.0	18	25	44	69	99	135	176	222	275	332	395
15	0.1	0.2	0.8	1.9	3.4	5.3	7.6	10.3	13.4	21	30	54	84	121	165	215	272	336	407	484
20	0.1	0.2	1.0	2.2	3.9	6.1	8.7	11.9	15.5	25	35	62	97	140	190	248	314	388	469	559
25	0.1	0.3	1.1	2.4	4.3	6.8	9.8	13.3	17.3	28	39	69	108	156	212	277	351	434	525	624
30	0.1	0.3	1.2	2.6	4.8	7.4	10.7	14.5	19.0	30	43	76	119	171	233	304	385	475	574	684
35	0.1	0.3	1.3	2.9	5.1	8.0	11.5	15.7	20.5	33	46	82	128	185	251	328	415	513	620	738
40	0.1	0.3	1.4	3.1	5.5	8.6	12.3	16.8	21.9	35	49	88	137	197	268	351	444	548	663	789
45	0.1	0.4	1.5	3.3	5.8	9.1	13.1	17.8	23.2	37	52	93	145	209	285	372	470	581	703	836
50	0.1	0.4	1.5	3.4	6.1	9.6	13.8	18.7	24.5	39	55	98	153	220	300	392	496	612	740	881
55	0.1	0.4	1.6	3.6	6.4	10.0	14.4	19.6	25.7	41	58	103	160	231	314	411	520	641	776	924
60	0.1	0.4	1.7	3.8	6.7	10.5	15.1	20.5	26.8	43	60	107	167	241	328	429	542	670	810	964
65	0.1	0.4	1.7	3.9	7.0	10.9	15.7	21.3	27.9	45	63	111	174	251	341	446	564	697	843	1003
70	0.1	0.5	1.8	4.1	7.2	11.3	16.3	22.1	28.9	46	65	116	181	260	354	463	585	723	874	1041
75	0.1	0.5	1.9	4.2	7.5	11.7	16.8	22.9	29.9	48	67	120	187	269	366	479	606	748	905	1077
80	0.1	0.5	1.9	4.3	7.7	12.1	17.4	23.6	30.9	50	70	124	193	278	378	494	625	772	934	1112
85	0.1	0.5	2.0	4.5	8.0	12.4	17.9	24.4	31.6	51	72	127	199	285	390	509	644	795	962	1145
90	0.1	0.5	2.0	4.6	8.2	12.8	18.4	25.1	32.7	53	74	131	204	294	401	524	663	818	990	1178
95	0.1	0.5	2.1	4.7	8.4	13.1	18.9	25.7	33.6	54	76	134	210	302	412	538	680	840	1016	1210
100	0.1	0.5	2.2	4.9	8.6	13.5	19.4	26.4	34.5	55	78	138	215	310	422	551	698	861	1042	1241
105	0.1	0.6	2.2	5.0	8.8	13.8	19.9	27.0	35.3	57	79	141	221	318	432	565	715	882	1068	1271
110	0.1	0.6	2.3	5.1	9.0	14.1	20.3	27.6	36.1	58	81	144	226	325	442	578	731	903	1092	1300

1 psi = 27.68" H<sub>2</sub>O

discharge coefficient = 0.65

Air Temperature = 70 deg F

Airflow in CFM

## Vacuum

Orifice Diameters - Inches

Vacuum " Hg	1/32	1/16	1/8	3/16	1/4	5/16	3/8	7/16	1/2	5/8	3/4	1	1-1/4	1-1/2	1-3/4	2.0	2-1/4	2-1/2	2-3/4	3
0.5	0.0	0.1	0.6	1.3	2.2	3.5	5.1	6.9	9	14	20	36	56	81	110	144	182	225	272	324
1	0.0	0.2	0.8	1.8	3.1	4.9	7.1	9.6	13	20	28	50	79	113	154	202	255	315	381	453
2	0.1	0.3	1.1	2.5	4.4	6.8	9.8	13.0	17	27	39	70	109	157	214	280	354	437	529	629
3	0.1	0.3	1.3	3.0	5.2	8.2	11.8	16.0	21	33	47	84	131	189	257	336	425	525	635	756
4	0.1	0.4	1.5	3.3	5.9	9.3	13.4	18.0	24	37	53	95	148	214	291	380	481	594	718	855
5	0.1	0.4	1.6	3.7	6.5	10.0	14.6	20.0	26	41	58	104	162	234	318	416	526	650	786	936
6	0.1	0.4	1.7	3.9	7.0	11.0	15.7	21.0	28	44	63	111	174	251	341	446	564	696	842	1002
7	0.1	0.5	1.8	4.1	7.3	11.0	16.5	22.0	29	46	66	118	184	264	360	470	595	735	889	1058
8	0.1	0.5	1.9	4.3	7.7	12.0	17.3	23.0	31	48	69	123	192	276	376	491	621	766	927	1104
9	0.1	0.5	2.0	4.5	7.9	12.0	17.8	24.0	32	50	71	127	198	285	388	507	642	792	959	1141
10	0.1	0.5	2.0	4.6	8.1	13.0	18.3	25.0	33	51	73	130	203	293	398	520	659	813	984	1171
11	0.1	0.5	2.1	4.7	8.3	13.0	18.7	25.0	33	52	76	133	207	298	406	530	671	829	1003	1193
12	0.1	0.5	2.1	4.7	8.4	13.0	18.9	26.0	34	52	76	134	210	302	412	538	680	840	1016	1210
13	0.1	0.5	2.1	4.8	8.5	13.0	19.1	26.0	34	53	76	135	212	305	415	542	686	847	1025	1219
14	0.1	0.5	2.1	4.8	8.5	13.0	19.1	26.0	34	53	76	136	212	306	416	544	688	849	1028	1223
15	0.1	0.5	2.1	4.8	8.5	13.0	19.1	26.0	34	53	76	136	212	306	416	544	688	849	1028	1223

1" HG = 13.6" H<sub>2</sub>O

discharge coefficient = 0.65

Air Temperature = 70 deg F

Airflow in CFM